

UBC Math 100: Differential Calculus

Practice Book for AY 2024/25

This practice book is a companion text for the Math 100 textbook. It consists primarily of content drawn from three open-source textbooks:

- *CLP-1 Differential Calculus* by Joel Feldman, Andrew Rechnitzer, and Elyse Yeager
Copyright © 2016–24 CC-BY-NC-SA 4.0
- *Differential Calculus for the Life Sciences* by Leah Edelstein-Keshet
Copyright © 2020 CC-BY-NC-SA 4.0
- *Optimal, Integral, Likely* prepared by Bruno Belevan, Parham Hamidi, Nisha Malhotra, and Elyse Yeager
Copyright © 2020-21 CC-BY-NC-SA, which is itself largely based on *CLP-3 Multivariable Calculus* by Joel Feldman, Andrew Rechnitzer, and Elyse Yeager
Copyright © 2016–2024 CC-BY-NC-SA 4.0

This document was typeset on Monday 7th October, 2024.



►► Licenses and attributions

Copyright ©2024 Kelly Paton, Elyse Yeager

Cover art: [Round textured structure with holes](#) by [Simone Hutsch](#) is reproduced with a [Royalty-Free Commercial License](#). It is *not* creative commons.

Except where noted, this work is licensed under the Creative Commons Attribution-NonCommercial-ShareAlike 4.0 International License. You can view a copy of the license at <https://creativecommons.org/licenses/by-nc-sa/4.0/>.



The public-facing webpage for the project is <https://personal.math.ubc.ca/~elyse/Math100Text/>.

Source files can be found at the repository [on gitlab](#) (public version pending).

The creation of this resource was supported by a [UBC OER Grant](#).

This text contains new material as well as material adapted from open sources.

- Chapter 1 is adapted from Keshet, Chapter 1.
- Chapter 2 is mostly adapted from CLP.
 - 2.1 is adapted from Section 1.3
 - 2.1.1 is adapted from Section 1.4
 - 2.1.2 is adapted from Section 1.5
 - 2.2 is adapted from Keshet Chapter 1
 - 2.3 is adapted from Section 1.6
- Chapter 3 is adapted from CLP.
 - Subsection 3.2 is adapted from Section 2.1
 - Subsection 3.3 is adapted from Section 2.2
 - Subsection 3.4 is adapted from Section 2.14
 - Subsection 3.5 is adapted from Section 2.7
- Chapter 4 is adapted from CLP–1
 - Section 4.1 is adapted from Section 2.4
 - The unnumbered Section “Using the arithmetic of derivatives – examples” (starting page 37) is adapted from Section 2.6
 - Section 4.2 is adapted from Section 2.8
 - Section 4.3 is adapted from Section 2.9
 - Section 4.4 is adapted from Section 2.10

-
- Section 4.5 is adapted from Section 2.11
 - Section 4.7 is adapted from Section 2.12
 - Chapter 5 is adapted from CLP Section 3.2
 - Chapter 6 is adapted from CLP Section 3.7
 - Chapter 7 is adapted from CLP Section 3.6
 - Section 7.1 is adapted from Section 3.6.1
 - Section 7.2 is adapted from Section 3.6.2
 - Section 7.3 is adapted from Section 3.6.3
 - Section 7.4 is adapted from Section 3.6.4
 - Section 7.6 is adapted from Section 3.6.6
 - Chapter 8 is adapted from both CLP and Keshet.
 - Section 8.1 is adapted from Section 3.5.1
 - Section 8.2 is adapted from Section 3.5.2
 - Section 8.3 is adapted from Section 3.5.3
 - Section 8.4 is adapted from Keshet, Chapter 7
 - Chapter 9 is adapted from CLP Section 3.4
 - Section 9.1 is adapted from Section 3.4.1
 - Section 9.2 is adapted from Section 3.4.2
 - Section 9.3 is adapted from Section 3.4.3
 - Section 9.4 is adapted from Section 3.4.4
 - Section 9.5 is adapted from Section 3.4.5
 - Section 9.6 is adapted from Section 3.4.8
 - Chapter 10 questions 1 through 5 are new content; questions 6 through 9 are from Keshet Chapter 5.
 - Chapter 11 is adapted from Keshet Ch 11
 - Questions 20 through 27 of Chapter 12 are new content; the rest are adapted from Keshet Ch 12.
 - Chapter 13 is adapted from Keshet Ch 13
 - Chapter 14 is adapted from OIL chapter 1, which is itself based on CLP–3 chapter 1.
 - Chapter 15 is adapted from OIL Sections 2.1-2.2, which are based on CLP–2 Chapter 2
 - Chapter 16 is adapted from OIL Sections 2.3-2.5, which are based on CLP–3 Chapter 2

HOW TO USE THIS BOOK

▲ Introduction

First of all, welcome to Calculus!

This book is written as a companion to the Math 100 textbook.

►► How to Work Questions

This book is organized into four sections: Questions, Hints, Answers, and Solutions. As you are working problems, resist the temptation to prematurely peek at the back! It's important to allow yourself to struggle for a time with the material. Even professional mathematicians don't always know right away how to solve a problem. The art is in gathering your thoughts and figuring out a strategy to use what you know to find out what you don't.

If you find yourself at a real impasse, go ahead and look for a hint in the Hints section. Think about it for a while, and don't be afraid to read back in the notes to look for a key idea that will help you proceed. If you still can't solve the problem, well, we included the Solutions section for a reason! As you're reading the solutions, try hard to understand why we took the steps we did, instead of memorizing step-by-step how to solve that one particular problem.

If you struggled with a question quite a lot, it's probably a good idea to return to it in a few days. That might have been enough time for you to internalize the necessary ideas, and you might find it easily conquerable. Pat yourself on the back—sometimes math makes you feel good! If you're still having troubles, read over the solution again, with an emphasis on understanding why each step makes sense.

One of the reasons so many students are required to study calculus is the hope that it will improve their problem-solving skills. In this class, you will learn lots of concepts, and be asked to apply them in a variety of situations. Often, this will involve answering one really big problem by breaking it up into manageable chunks, solving those chunks, then putting the pieces back together. When you see a particularly long question, remain calm and look for a way to break it into pieces you can handle.

►► Working with Friends

Study buddies are fantastic! If you don't already have friends in your class, you can ask your neighbours in lecture to form a group. Often, a question that you might bang your head against for an hour can be easily cleared up by a friend who sees what you've missed. Regular study times make sure you don't procrastinate too much, and friends help you maintain a positive attitude when you might otherwise succumb to frustration. Struggle in mathematics is desirable, but suffering is not.

When working in a group, make sure you try out problems on your own before coming together to discuss with others. Learning is a process, and getting answers to questions that you haven't considered on your own can rob you of the practice you need to master skills and concepts, and the tenacity you need to develop to become a competent problem-solver.

►► Types of Questions

The majority of questions in this book come from CLP Calculus, and have the organization shown below. However, some chapters are taken from Keshet's *Differential Equations for the Life Sciences*, and have slightly different organization. Those questions aren't organized into stages, and don't have hints or solutions.

Q[1](*):

In addition to original problems, this book contains problems pulled from quizzes and exams given at UBC for Math 100 and 180 (first-semester calculus) and Math 120 (honours first-semester calculus). These problems are marked with a star. The authors would like to acknowledge the contributions of the many people who collaborated to produce these exams over the years.

Instructions and other comments that are attached to more than one question are written in this font. The questions are organized into Stage 1, Stage 2, and Stage 3.

►► Stage 1

The first category is meant to test and improve your understanding of basic underlying concepts. These often do not involve much calculation. They range in difficulty from very basic reviews of definitions to questions that require you to be thoughtful about the concepts covered in the section.

►► Stage 2

Questions in this category are for practicing skills. It's not enough to understand the philosophical grounding of an idea: you have to be able to apply it in appropriate situations. This takes practice!

►► Stage 3

The last questions in each section go a little farther than Stage 2. Often they will combine more than one idea, incorporate review material, or ask you to apply your understanding of a concept to a new situation.

In exams, as in life, you will encounter questions of varying difficulty. A good skill to practice is recognizing the level of difficulty a problem poses. Exams will have some easy questions, some standard questions, and some harder questions.

CONTENTS

- How to use this book** **i**

- I The questions** **1**

- 1 Power Functions as Building Blocks** **3**

- 2 Limits** **9**
 - 2.1 Quick review of limits 9
 - 2.1.1 Calculating limits with limit laws 11
 - 2.1.2 Limits at infinity 17
 - 2.2 Asymptotes 19
 - 2.3 Limits and continuity 20

- 3 Introduction to the Derivative** **23**
 - 3.1 Review: lines 23
 - 3.2 Slopes and rates of change 23
 - 3.3 The derivative 26
 - Interpretations of the derivative 30
 - 3.4 Higher order derivatives 31
 - 3.5 Derivatives of exponential functions 32

- 4 Computing Derivatives** **35**
 - 4.1 Arithmetic of derivatives 35
 - Using the arithmetic of derivatives - examples 37
 - 4.2 Trigonometric functions and their derivatives 39
 - 4.3 The chain rule 42
 - 4.4 Logarithmic differentiation 45
 - 4.5 Implicit differentiation 48
 - 4.6 Inverse functions 51
 - 4.7 Inverse trig functions and their derivatives 51

5	Related Rates	55
6	L'Hôpital's Rule and Indeterminate Forms	63
7	Sketching Graphs	67
7.1	Domain, intercepts and asymptotes	67
7.2	First derivative - increasing or decreasing	68
7.3	Second derivative - concavity	70
7.4	(optional) Symmetries	71
7.5	A checklist for sketching	74
7.6	Sketching examples	74
8	Optimization	79
8.1	Local and global maxima and minima	79
8.2	Finding global maxima and minima	81
8.3	Max/min examples	82
8.4	Sample optimization problems	84
9	Taylor Polynomials	91
9.1	Zeroth approximation	91
9.2	Linear approximation	93
9.3	Quadratic approximation	94
9.4	Still Better approximations	96
9.5	Some examples	97
9.6	(Flavour A) Error in Taylor polynomials	98
10	(Flavour A) Newton's Method	101
11	(Flavours A, B) Introduction to Differential Equations	103
12	(Flavours A, B) Solving Differential Equations	109
13	(Flavours A, B) Qualitative Methods for Differential Equations	117
14	(Flavour C) Geometry in Three Dimensions	123
14.1	Points and planes	123
14.2	Functions of two variables	126
14.3	(optional) Sketching surfaces in 3D	128
15	(Flavour C) Partial Derivatives	131
15.1	Partial derivatives	131
15.2	Higher order derivatives	134
16	(Flavour C) Optimization of Multivariable Functions	137
16.1	Local maximum and minimum values	137
16.2	Absolute minima and maxima	141
16.3	Lagrange multipliers	145

II	Hints to problems	149
1	Power Functions as Building Blocks	151
2.1	Quick review of limits	151
2.1.1	Calculating limits with limit laws	151
2.1.2	Limits at infinity	153
2.2	Asymptotes	154
2.3	Limits and continuity	154
3.1	Review: lines	155
3.2	Slopes and rates of change	155
3.3	The derivative	155
3.3	156
3.4	Higher order derivatives	157
3.5	Derivatives of exponential functions	157
4.1	Arithmetic of derivatives	157
4.1	158
4.2	Trigonometric functions and their derivatives	159
4.3	The chain rule	160
4.4	Logarithmic differentiation	161
4.5	Implicit differentiation	163
4.6	Inverse functions	164
4.7	Inverse trig functions and their derivatives	164
5	Related Rates	165
6	L'Hôpital's Rule and Indeterminate Forms	167
7.1	Domain, intercepts and asymptotes	168
7.2	First derivative - increasing or decreasing	168
7.3	Second derivative - concavity	168
7.4	(optional) Symmetries	168
7.5	A checklist for sketching	169
7.6	Sketching examples	169
8.1	Local and global maxima and minima	170
8.2	Finding global maxima and minima	170
8.3	Max/min examples	170
8.4	Sample optimization problems	172
9.1	Zeroth approximation	172
9.2	Linear approximation	172
9.3	Quadratic approximation	173
9.4	Still Better approximations	173
9.5	Some examples	174
9.6	(Flavour A) Error in Taylor polynomials	175
10	(Flavour A) Newton's Method	176
11	(Flavours A, B) Introduction to Differential Equations	176
12	(Flavours A, B) Solving Differential Equations	176
13	(Flavours A, B) Qualitative Methods for Differential Equations	176
14.1	Points and planes	176
14.2	Functions of two variables	177
14.3	(optional) Sketching surfaces in 3D	178
15.1	Partial derivatives	178

15.2	Higher order derivatives	179
16.1	Local maximum and minimum values	179
16.2	Absolute minima and maxima	180
16.3	Lagrange multipliers	180

III	Answers to problems	183
1	Power Functions as Building Blocks	185
2.1	Quick review of limits	186
2.1.1	Calculating limits with limit laws	188
2.1.2	Limits at infinity	191
2.2	Asymptotes	192
2.3	Limits and continuity	192
3.1	Review: lines	193
3.2	Slopes and rates of change	193
3.3	The derivative	194
3.3	195
3.4	Higher order derivatives	196
3.5	Derivatives of exponential functions	196
4.1	Arithmetic of derivatives	196
4.1	198
4.2	Trigonometric functions and their derivatives	201
4.3	The chain rule	203
4.4	Logarithmic differentiation	205
4.5	Implicit differentiation	207
4.6	Inverse functions	209
4.7	Inverse trig functions and their derivatives	209
5	Related Rates	212
6	L'Hôpital's Rule and Indeterminate Forms	213
7.1	Domain, intercepts and asymptotes	215
7.2	First derivative - increasing or decreasing	215
7.3	Second derivative - concavity	215
7.4	(optional) Symmetries	216
7.5	A checklist for sketching	218
7.6	Sketching examples	218
8.1	Local and global maxima and minima	226
8.2	Finding global maxima and minima	228
8.3	Max/min examples	229
8.4	Sample optimization problems	230
9.1	Zeroth approximation	230
9.2	Linear approximation	231
9.3	Quadratic approximation	232
9.4	Still Better approximations	233
9.5	Some examples	233
9.6	(Flavour A) Error in Taylor polynomials	234
10	(Flavour A) Newton's Method	235
11	(Flavours A, B) Introduction to Differential Equations	236

12	(Flavours A, B) Solving Differential Equations	238
13	(Flavours A, B) Qualitative Methods for Differential Equations	240
14.1	Points and planes	246
14.2	Functions of two variables	249
14.3	(optional) Sketching surfaces in 3D	251
15.1	Partial derivatives	258
15.2	Higher order derivatives	259
16.1	Local maximum and minimum values	260
16.2	Absolute minima and maxima	263
16.3	Lagrange multipliers	265

IV Solutions to problems 267

1	Power Functions as Building Blocks	269
2.1	Quick review of limits	269
2.1.1	Calculating limits with limit laws	271
2.1.2	Limits at infinity	289
2.2	Asymptotes	297
2.3	Limits and continuity	297
3.1	Review: lines	299
3.2	Slopes and rates of change	299
3.3	The derivative	302
3.3	312
3.4	Higher order derivatives	314
3.5	Derivatives of exponential functions	314
4.1	Arithmetic of derivatives	315
4.1	321
4.2	Trigonometric functions and their derivatives	328
4.3	The chain rule	338
4.4	Logarithmic differentiation	351
4.5	Implicit differentiation	363
4.6	Inverse functions	372
4.7	Inverse trig functions and their derivatives	373
5	Related Rates	384
6	L'Hôpital's Rule and Indeterminate Forms	408
7.1	Domain, intercepts and asymptotes	416
7.2	First derivative - increasing or decreasing	418
7.3	Second derivative - concavity	420
7.4	(optional) Symmetries	422
7.5	A checklist for sketching	427
7.6	Sketching examples	427
8.1	Local and global maxima and minima	456
8.2	Finding global maxima and minima	461
8.3	Max/min examples	464
8.4	Sample optimization problems	475
9.1	Zeroth approximation	475
9.2	Linear approximation	476

9.3	Quadratic approximation	479
9.4	Still Better approximations	486
9.5	Some examples	489
9.6	(Flavour A) Error in Taylor polynomials	498
10	(Flavour A) Newton's Method	513
11	(Flavours A, B) Introduction to Differential Equations	516
12	(Flavours A, B) Solving Differential Equations	516
13	(Flavours A, B) Qualitative Methods for Differential Equations	518
14.1	Points and planes	519
14.2	Functions of two variables	523
14.3	(optional) Sketching surfaces in 3D	533
15.1	Partial derivatives	545
15.2	Higher order derivatives	551
16.1	Local maximum and minimum values	556
16.2	Absolute minima and maxima	567
16.3	Lagrange multipliers	584

Part I

THE QUESTIONS

POWER FUNCTIONS AS BUILDING BLOCKS

Exercises

Jump to [HINTS](#), [ANSWERS](#), [SOLUTIONS](#) or [TABLE OF CONTENTS](#).

Remark: these questions are adapted from *Differential Calculus for the Life Sciences* by Leah Edelstein-Keshet, Chapter 1. That book intentionally *does not* publish full solutions, and only provides answers to selected questions.

►► Stage 1

Q[1]:

[answer](#)

Consider the functions $y = x^n$, $y = x^{1/n}$, $y = x^{-n}$, where n is a positive integer ($n = 1, 2, \dots$).

- (a) Which of these functions increases most steeply for values of x greater than 1?
- (b) Which decreases for large values of x ?
- (c) Which functions are not defined for negative x values?
- (d) Compare the values of these functions for $0 < x < 1$.
- (e) Which of these functions are not defined at $x = 0$?

Q[2]:

Consider the power function

$$y = ax^n, \quad -\infty < x < \infty.$$

Explain, possibly using a sketch, how the shape of the function changes when the coefficient a increases or decreases (for fixed n). How is this change in shape different from the shape change that results from changing the power n ?

Q[3]:

[answer](#)

Consider the graphs of the simple functions $y = x$, $y = x^2$, and $y = x^3$. Describe what happens to each of these graphs when the functions are *transformed* as follows:

- (a) $y = Ax$, $y = Ax^2$, and $y = Ax^3$ where $A > 1$ is some constant.

(b) $y = x + a$, $y = x^2 + a$, and $y = x^3 + a$ where $a > 0$ is some constant.

(c) $y = (x - b)^2$, and $y = (x - b)^3$ where $b > 0$ is some constant.

Q[4]:

Consider the function

$$f(x) = \frac{A}{x^a}$$

where $A > 0$, $a > 1$, with a an integer. This is the same as the function $f(x) = Ax^{-a}$, which is a power function with a negative power.

(a) Sketch a rough graph of this function for $x > 0$.

(b) How does the function change if A is increased?

(c) How does the function change if a is increased?

Q[5]:

Sketch the graphs of the following functions:

(a) $y = x^2$,

(b) $y = (x + 4)^2$,

(c) $y = a(x - b)^2 + c$ for the case $a > 0$, $b > 0$, $c > 0$.

(d) Comment on the effects of the constants a , b , c on the properties of the graph of $y = a(x - b)^2 + c$.

Q[6]:

(a) Sketch the graph of the function $y = \rho x - x^5$ for positive and negative values of the constant ρ . Comment on behaviour close to zero and far away from zero.

(b) What are the zeros of this function and how does this depend on ρ ?

►► Stage 2

Q[7]:

Use arguments from Section 1.2 to sketch graphs of the following polynomials:

(a) $y = 2x^5 - 3x^2$

(b) $y = x^3 - 4x^5$

Q[8]:

[answer](#)

(a) Consider the two functions $f(x) = 3x^2$ and $g(x) = 2x^5$. Find all x -values where these functions intersect.

(b) Repeat for functions $f(x) = x^3$ and $g(x) = 4x^5$.

Q[9]:

[answer](#)

Consider functions $f(x) = Ax^n$ and $g(x) = Bx^m$. Suppose $m > n > 1$ are integers, and $A, B > 0$.

Determine the values of x at which the the functions are the same - i.e. they intersect. Are there two places of intersection or three? How does this depend on the integer $m - n$?

Note: The point $(0,0)$ is always an intersection point. Thus, we are asking: when is there only *one* more and when there are *two* more intersection points?

Q[10]: answer

Find the intersection of each pair of curves.

(a) $y = \sqrt{x}, y = x^2$

(b) $y = -\sqrt{x}, y = x^2$

(c) $y = x^2 - 1, \frac{x^2}{4} + y^2 = 1$

Q[11]: answer

Find the range m such that the equation $x^2 - 2x - m = 0$ has two unequal roots.

Q[12]: answer

Consider two functions of the form

$$f(x) = \frac{A}{x^a}, \quad g(x) = \frac{B}{x^b}.$$

Suppose that $A, B > 0$, $a, b > 1$ and that $A > B$. Determine the x -values where these functions intersect for positive x values.

Q[13]: answer

Find all real zeros of the following polynomials:

(a) $x^3 - 2x^2 - 3x$,

(b) $x^5 - 1$,

(c) $3x^2 + 5x - 2$.

Q[14]: answer

Find the points of intersection of the functions $y = x^3 + x^2 - 2x + 1$ and $y = x^3$.

Q[15]: answer

According to the biologist Breder, two fish in a school prefer to stay some specific distance apart. Breder suggested that the fish that are a distance x apart are attracted to one another by a force $F_A(x) = A/x^a$ and repelled by a second force $F_R(x) = R/x^r$, to keep from getting too close. He found the preferred spacing distance (also called the *individual distance*) by determining the value of x at which the repulsion and the attraction exactly balance.

Find the *individual distance* in terms of the quantities A, R, a, r (all assumed to be positive constants.)

Q[16]: answer

The volume V and surface area S of a cube whose sides have length a are given by the formulae

$$V = a^3, \quad S = 6a^2.$$

Note that these relationships are expressed in terms of power functions. The independent variable is a , not x . We say that “ V is a function of a ” (and also “ S is a function of a ”).

(a) Sketch V as a function of a and S as a function of a on the same set of axes. Which one grows faster as a increases?

(b) What is the ratio of the volume to the surface area; that is, what is $\frac{V}{S}$ in terms of a ? Sketch a graph of $\frac{V}{S}$ as a function of a .

(c) The formulae above tell us the volume and the area of a cube of a given side length. Suppose we are given either the volume or the surface area and asked to find the side.

(i) Find the length of the side as a function of the volume (i.e. express a in terms of V).

(ii) Find the side as a function of the surface area.

(iii) Use your results to find the side of a cubic tank whose volume is 1 litre.

Note that 1 litre = 10^3 cm³.

(iv) Find the side of a cubic tank whose surface area is 10 cm².

Q[17]:

answer

The volume V and surface area S of a sphere of radius r are given by the formulae

$$V = \frac{4\pi}{3}r^3, \quad S = 4\pi r^2.$$

Note that these relationships are expressed in terms of power functions with constant multiples such as 4π . The independent variable is r , not x . We say that “ V is a function of r ” (and also “ S is a function of r ”).

(a) Sketch V as a function of r and S as a function of r on the same set of axes. Which one grows faster as r increases?

(b) What is the ratio of the volume to the surface area; that is, what is $\frac{V}{S}$ in terms of r ? Sketch a graph of $\frac{V}{S}$ as a function of r .

(c) The formulae above tell us the volume and the area of a sphere of a given radius. But suppose we are given either the volume or the surface area and asked to find the radius.

(i) Find the radius as a function of the volume (i.e. express r in terms of V).

(ii) Find the radius as a function of the surface area.

(iii) Use your results to find the radius of a balloon whose volume is 1 litre.

(iv) Find the radius of a balloon whose surface area is 10 cm².

(v) Find the surface area of a balloon whose volume is 36 cm³.

►► Stage 3

Q[18]:

answer

Answer the following by solving for x in each case. Find all values of x for which the following functions cross the x -axis (equivalently: the **zeros** of the function, or **roots** of the equation $f(x) = 0$.)

(a) $f(x) = I - \gamma x$, where I, γ are positive constants.

(b) $f(x) = I - \gamma x + \epsilon x^2$, where I, γ, ϵ are positive constants. Are there cases where this function does not cross the x axis?

(c) In the case where the root(s) exist in part (b), are they positive, negative or of mixed signs?

Q[19]:

[answer](#)

Properties of animals are often related to their physical size or mass. For example, the metabolic rate of the animal (R), and its pulse rate (P) may be related to its body mass m by the approximate formulae $R = Am^b$ and $P = Cm^d$, where A, C, b, d are positive constants. Such relationships are known as *allometric* relationships.

- (a) Use these formulae to derive a relationship between the metabolic rate and the pulse rate (*hint: eliminate m*).
- (b) A similar process can be used to relate the Volume $V = (4/3)\pi r^3$ and surface area $S = 4\pi r^2$ of a sphere to one another. Eliminate r to find the corresponding relationship between volume and surface area for a sphere.

Q[20]:

This question has been deleted, because it does not fit nicely with Math 100 assessable content.

Q[21]:

[answer](#)

It is known that the *rate* v at which a certain chemical reaction proceeds depends on the *concentration* of the reactant c according to the formula

$$v = \frac{Kc^2}{a^2 + c^2},$$

where K, a are positive constants. When the chemist plots the values of the quantity $1/v$ (on the vertical axis) versus the values of $1/c^2$ (on the horizontal axis), she finds that the points are best described by a straight line with slope 8 that intersects the vertical axis at 2. Use this result to find the values of the constants K and a .

LIMITS

2.1▲ Quick review of limits

Exercises

Jump to [HINTS](#), [ANSWERS](#), [SOLUTIONS](#) or [TABLE OF CONTENTS](#).

►► Stage 1

Q[1]:

[answer](#) [solution](#)

Given the function shown below, evaluate the following:

- (a) $\lim_{x \rightarrow -2} f(x)$
 (b) $\lim_{x \rightarrow 0} f(x)$
 (c) $\lim_{x \rightarrow 2} f(x)$

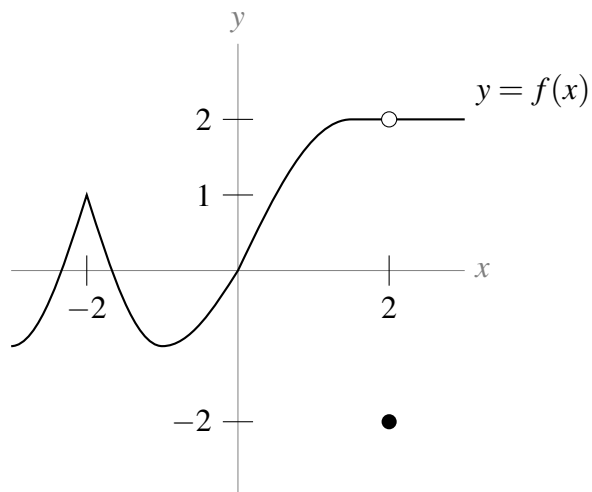

Q[2]:

[hint](#) [answer](#) [solution](#)

Given the function shown below, evaluate $\lim_{x \rightarrow 0} f(x)$.

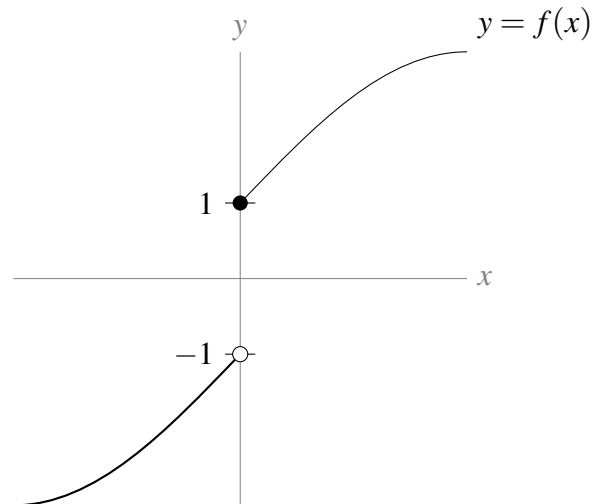

Q[3]:

Given the function shown below, evaluate:

[hint](#) [answer](#) [solution](#)

(a) $\lim_{x \rightarrow -1^-} f(x)$

(b) $\lim_{x \rightarrow -1^+} f(x)$

(c) $\lim_{x \rightarrow -1} f(x)$

(d) $\lim_{x \rightarrow -2^+} f(x)$

(e) $\lim_{x \rightarrow 2^-} f(x)$

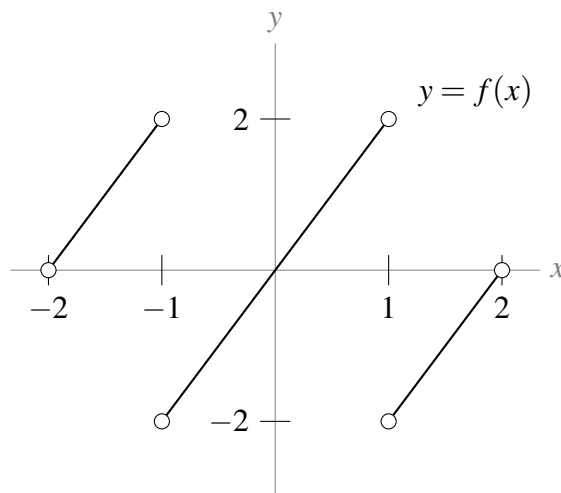

Q[4]:

Draw a curve $y = f(x)$ with $\lim_{x \rightarrow 3} f(x) = f(3) = 10$.

[answer](#) [solution](#)

Q[5]:

Draw a curve $y = f(x)$ with $\lim_{x \rightarrow 3} f(x) = 10$ and $f(3) = 0$.

[hint](#) [answer](#) [solution](#)

Q[6]: [hint](#) [answer](#) [solution](#)
 Suppose $\lim_{x \rightarrow 3} f(x) = 10$. True or false: $f(3) = 10$.

Q[7]: [hint](#) [answer](#) [solution](#)
 Suppose $f(3) = 10$. True or false: $\lim_{x \rightarrow 3} f(x) = 10$.

Q[8]: [hint](#) [answer](#) [solution](#)
 Suppose $f(x)$ is a function defined on all real numbers, and $\lim_{x \rightarrow -2} f(x) = 16$. What is $\lim_{x \rightarrow -2^-} f(x)$?

Q[9]: [hint](#) [answer](#) [solution](#)
 Suppose $f(x)$ is a function defined on all real numbers, and $\lim_{x \rightarrow -2^-} f(x) = 16$. What is $\lim_{x \rightarrow -2} f(x)$?

►► Stage 2

In Questions 10 through 17, evaluate the given limits. If you aren't sure where to begin, it's nice to start by drawing the function.

Q[10]: [answer](#) [solution](#)
 $\lim_{t \rightarrow 0} \sin t$

Q[11]: [answer](#) [solution](#)
 $\lim_{x \rightarrow 0^+} \log x$

Q[12]: [answer](#) [solution](#)
 $\lim_{y \rightarrow 3} y^2$

Q[13]: [answer](#) [solution](#)
 $\lim_{x \rightarrow 0^-} \frac{1}{x}$

Q[14]: [hint](#) [answer](#) [solution](#)
 $\lim_{x \rightarrow 0} \frac{1}{x}$

Q[15]: [answer](#) [solution](#)
 $\lim_{x \rightarrow 0} \frac{1}{x^2}$

Q[16]: [hint](#) [answer](#) [solution](#)
 $\lim_{x \rightarrow 3} \frac{1}{10}$

Q[17]: [hint](#) [answer](#) [solution](#)
 $\lim_{x \rightarrow 3} f(x)$, where $f(x) = \begin{cases} \sin x & x \leq 2.9 \\ x^2 & x > 2.9 \end{cases}$.

2.1.1 ►► Calculating limits with limit laws

Exercises

Jump to [HINTS](#), [ANSWERS](#), [SOLUTIONS](#) or [TABLE OF CONTENTS](#).

►► Stage 1

Q[1]:

[answer](#) [solution](#)

Suppose $\lim_{x \rightarrow a} f(x) = 0$ and $\lim_{x \rightarrow a} g(x) = 0$. Which of the following limits can you compute, given this information?

(a) $\lim_{x \rightarrow a} \frac{f(x)}{2}$

(b) $\lim_{x \rightarrow a} \frac{2}{f(x)}$

(c) $\lim_{x \rightarrow a} \frac{f(x)}{g(x)}$

(d) $\lim_{x \rightarrow a} f(x)g(x)$

Q[2]:

[hint](#) [answer](#) [solution](#)

Give two functions $f(x)$ and $g(x)$ that satisfy $\lim_{x \rightarrow 3} f(x) = \lim_{x \rightarrow 3} g(x) = 0$ and $\lim_{x \rightarrow 3} \frac{f(x)}{g(x)} = 10$.

Q[3]:

[hint](#) [answer](#) [solution](#)

Give two functions $f(x)$ and $g(x)$ that satisfy $\lim_{x \rightarrow 3} f(x) = \lim_{x \rightarrow 3} g(x) = 0$ and $\lim_{x \rightarrow 3} \frac{f(x)}{g(x)} = 0$.

Q[4]:

[answer](#) [solution](#)

Give two functions $f(x)$ and $g(x)$ that satisfy $\lim_{x \rightarrow 3} f(x) = \lim_{x \rightarrow 3} g(x) = 0$ and $\lim_{x \rightarrow 3} \frac{f(x)}{g(x)} = \infty$.

Q[5]:

[hint](#) [answer](#) [solution](#)

Suppose $\lim_{x \rightarrow a} f(x) = \lim_{x \rightarrow a} g(x) = 0$. What are the possible values of $\lim_{x \rightarrow a} \frac{f(x)}{g(x)}$?

►► Stage 2

For Questions 6 through 39, evaluate the given limits.

Q[6]:

[hint](#) [answer](#) [solution](#)

$$\lim_{t \rightarrow 10} \frac{2(t-10)^2}{t}$$

Q[7]:

[hint](#) [answer](#) [solution](#)

$$\lim_{y \rightarrow 0} \frac{(y+1)(y+2)(y+3)}{\cos y}$$

Q[8]:

[hint](#) [answer](#) [solution](#)

$$\lim_{x \rightarrow 3} \left(\frac{4x-2}{x+2} \right)^4$$

Q[9](*):

[hint](#) [answer](#) [solution](#)

$$\lim_{t \rightarrow -3} \left(\frac{1-t}{\cos(t)} \right)$$

Q[10](*):

[hint](#) [answer](#) [solution](#)

$$\lim_{h \rightarrow 0} \frac{(2+h)^2 - 4}{2h}$$

Q[11](*):

[answer](#) [solution](#)

$$\lim_{t \rightarrow -2} \left(\frac{t-5}{t+4} \right)$$

Q[12](*):

[answer](#) [solution](#)

$$\lim_{x \rightarrow 1} \sqrt{5x^3 + 4}$$

Q[13](*):

[answer](#) [solution](#)

$$\lim_{t \rightarrow -1} \left(\frac{t-2}{t+3} \right)$$

Q[14](*):

[hint](#) [answer](#) [solution](#)

$$\lim_{x \rightarrow 1} \frac{\log(1+x) - x}{x^2}$$

Q[15](*):

[hint](#) [answer](#) [solution](#)

$$\lim_{x \rightarrow 2} \left(\frac{x-2}{x^2-4} \right)$$

Q[16](*):

[hint](#) [answer](#) [solution](#)

$$\lim_{x \rightarrow 4} \frac{x^2 - 4x}{x^2 - 16}$$

Q[17](*):

[hint](#) [answer](#) [solution](#)

$$\lim_{x \rightarrow 2} \frac{x^2 + x - 6}{x - 2}$$

Q[18](*):

[hint](#) [answer](#) [solution](#)

$$\lim_{x \rightarrow -3} \frac{x^2 - 9}{x + 3}$$

Q[19]:

[hint](#) [answer](#) [solution](#)

$$\lim_{t \rightarrow 2} \frac{1}{2} t^4 - 3t^3 + t$$

Q[20](*):

[hint](#) [answer](#) [solution](#)

$$\lim_{x \rightarrow -1} \frac{\sqrt{x^2 + 8} - 3}{x + 1}$$

Q[21](*):

[hint](#) [answer](#) [solution](#)

$$\lim_{x \rightarrow 1} \frac{\sqrt{x+2} - \sqrt{4-x}}{x-1}$$

Q[22](*):

[hint](#) [answer](#) [solution](#)

$$\lim_{x \rightarrow 3} \frac{\sqrt{x-2} - \sqrt{4-x}}{x-3}$$

Q[23]:

[hint](#) [answer](#) [solution](#)

$$\lim_{x \rightarrow 0} -x^2 \cos \left(\frac{3}{x} \right)$$

Q[24]:

This question has been deleted, because it does not fit nicely with Math 100 assessable content.

Q[25](*):

$$\lim_{x \rightarrow 0} x \sin^2 \left(\frac{1}{x} \right)$$

[hint](#) [answer](#) [solution](#)

Q[26]:

$$\lim_{w \rightarrow 5} \frac{2w^2 - 50}{(w - 5)(w - 1)}$$

[hint](#) [answer](#) [solution](#)

Q[27]:

$$\lim_{r \rightarrow -5} \frac{r}{r^2 + 10r + 25}$$

[hint](#) [answer](#) [solution](#)

Q[28]:

$$\lim_{x \rightarrow -1} \sqrt{\frac{x^3 + x^2 + x + 1}{3x + 3}}$$

[hint](#) [answer](#) [solution](#)

Q[29]:

$$\lim_{x \rightarrow 0} \frac{x^2 + 2x + 1}{3x^5 - 5x^3}$$

[hint](#) [answer](#) [solution](#)

Q[30]:

$$\lim_{t \rightarrow 7} \frac{t^2 x^2 + 2tx + 1}{t^2 - 14t + 49}, \text{ where } x \text{ is a positive constant}$$

[hint](#) [answer](#) [solution](#)

Q[31]:

$$\lim_{d \rightarrow 0} x^5 - 32x + 15, \text{ where } x \text{ is a constant}$$

[hint](#) [answer](#) [solution](#)

Q[32]:

$$\lim_{x \rightarrow 1} (x - 1)^2 \sin \left[\left(\frac{x^2 - 3x + 2}{x^2 - 2x + 1} \right)^2 + 15 \right]$$

[hint](#) [answer](#) [solution](#)

Q[33](*):

Evaluate

$$\lim_{x \rightarrow 0} x^{1/101} \sin(x^{-100})$$

[hint](#) [answer](#) [solution](#)

or explain why this limit does not exist.

Q[34](*):

$$\lim_{x \rightarrow 2} \frac{x^2 - 4}{x^2 - 2x}$$

[hint](#) [answer](#) [solution](#)

Q[35]:

$$\lim_{x \rightarrow 5} \frac{(x - 5)^2}{x + 5}$$

[hint](#) [answer](#) [solution](#)

Q[36]:

$$\text{Evaluate } \lim_{t \rightarrow \frac{1}{2}} \frac{\frac{1}{3t^2} + \frac{1}{t^2 - 1}}{2t - 1}.$$

[hint](#) [answer](#) [solution](#)

Q[37]:

$$\text{Evaluate } \lim_{x \rightarrow 0} \left(3 + \frac{|x|}{x} \right).$$

[hint](#) [answer](#) [solution](#)

Q[38]:

[hint](#) [answer](#) [solution](#)

Evaluate $\lim_{d \rightarrow -4} \frac{|3d + 12|}{d + 4}$

Q[39]:

[hint](#) [answer](#) [solution](#)

Evaluate $\lim_{x \rightarrow 0} \frac{5x - 9}{|x| + 2}$.

Q[40]:

[hint](#) [answer](#) [solution](#)

Suppose $\lim_{x \rightarrow -1} f(x) = -1$. Evaluate $\lim_{x \rightarrow -1} \frac{xf(x) + 3}{2f(x) + 1}$.

Q[41](*):

[hint](#) [answer](#) [solution](#)

Find the value of the constant a for which $\lim_{x \rightarrow -2} \frac{x^2 + ax + 3}{x^2 + x - 2}$ exists.

Q[42]:

[answer](#) [solution](#)

Suppose $f(x) = 2x$ and $g(x) = \frac{1}{x}$. Evaluate the following limits.

(a) $\lim_{x \rightarrow 0} f(x)$

(b) $\lim_{x \rightarrow 0} g(x)$

(c) $\lim_{x \rightarrow 0} f(x)g(x)$

(d) $\lim_{x \rightarrow 0} \frac{f(x)}{g(x)}$

(e) $\lim_{x \rightarrow 2} [f(x) + g(x)]$

(f) $\lim_{x \rightarrow 0} \frac{f(x) + 1}{g(x + 1)}$

►► Stage 3

Q[43](*):

[hint](#) [answer](#) [solution](#)

$\lim_{x \rightarrow 2} \frac{\sqrt{x+7} - \sqrt{11-x}}{2x-4}$.

Q[44](*):

[hint](#) [answer](#) [solution](#)

$\lim_{t \rightarrow 1} \frac{3t-3}{2-\sqrt{5-t}}$.

Q[45]:

[hint](#) [answer](#) [solution](#)

The curve $y = f(x)$ is shown in the graph below. Sketch the graph of $y = \frac{1}{f(x)}$.

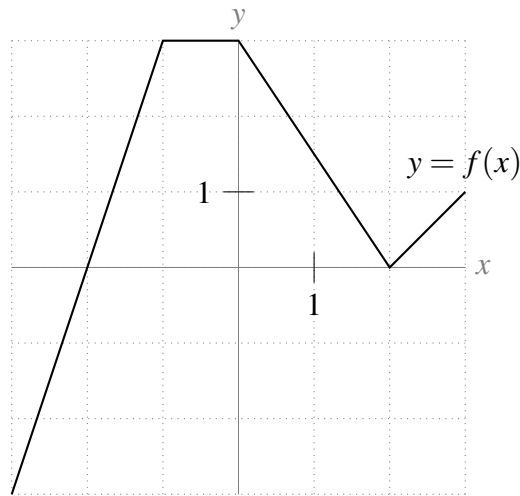

Q[46]:

[hint](#) [answer](#) [solution](#)

The graphs of functions $f(x)$ and $g(x)$ are shown in the graphs below. Use these to sketch the graph of $\frac{f(x)}{g(x)}$.

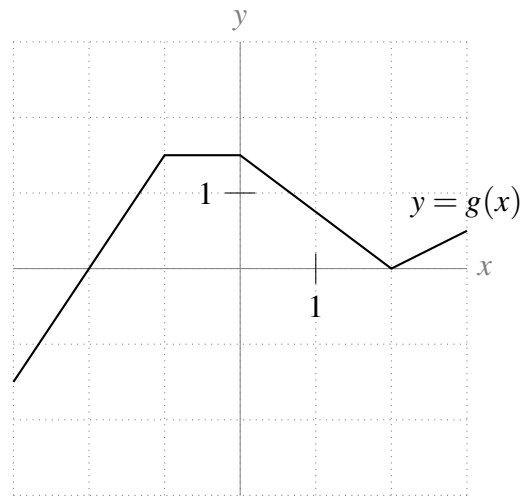
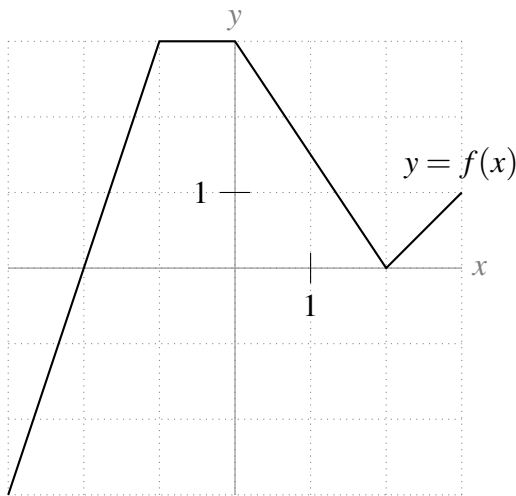

Q[47]:

[answer](#) [solution](#)

Let $f(x) = \frac{1}{x}$ and $g(x) = \frac{-1}{x}$.

- Evaluate $\lim_{x \rightarrow 0^+} f(x)$ and $\lim_{x \rightarrow 0^+} g(x)$.
- Evaluate $\lim_{x \rightarrow 0} [f(x) + g(x)]$
- Is it always true that $\lim_{x \rightarrow a} [f(x) + g(x)] = \lim_{x \rightarrow a} f(x) + \lim_{x \rightarrow a} g(x)$?

Q[48]:

[hint](#) [answer](#) [solution](#)

Suppose

$$f(x) = \begin{cases} x^2 + 3 & , x > 0 \\ 0 & , x = 0 \\ x^2 - 3 & , x < 0 \end{cases}$$

- Evaluate $\lim_{x \rightarrow 0^-} f(x)$.

(b) Evaluate $\lim_{x \rightarrow 0^+} f(x)$.

(c) Evaluate $\lim_{x \rightarrow 0} f(x)$.

Q[49]:

[hint](#) [answer](#) [solution](#)

Suppose

$$f(x) = \begin{cases} \frac{x^2 + 8x + 16}{x^2 + 30x - 4} & , x > -4 \\ x^3 + 8x^2 + 16x & , x \leq -4 \end{cases}$$

(a) Evaluate $\lim_{x \rightarrow -4^-} f(x)$.

(b) Evaluate $\lim_{x \rightarrow -4^+} f(x)$.

(c) Evaluate $\lim_{x \rightarrow -4} f(x)$.

2.1.2 ▶▶ Limits at infinity

Exercises

Jump to [HINTS](#), [ANSWERS](#), [SOLUTIONS](#) or [TABLE OF CONTENTS](#).

▶▶ Stage 1

Q[1]:

[hint](#) [answer](#) [solution](#)

Give a polynomial $f(x)$ with the property that both $\lim_{x \rightarrow \infty} f(x)$ and $\lim_{x \rightarrow -\infty} f(x)$ are (finite) real numbers.

Q[2]:

[hint](#) [answer](#) [solution](#)

Give a polynomial $f(x)$ that satisfies $\lim_{x \rightarrow \infty} f(x) \neq \lim_{x \rightarrow -\infty} f(x)$.

▶▶ Stage 2

Q[3]:

[hint](#) [answer](#) [solution](#)

Evaluate $\lim_{x \rightarrow \infty} 2^{-x}$

Q[4]:

[hint](#) [answer](#) [solution](#)

Evaluate $\lim_{x \rightarrow \infty} 2^x$

Q[5]:

[hint](#) [answer](#) [solution](#)

Evaluate $\lim_{x \rightarrow -\infty} 2^x$

Q[6]:

[hint](#) [answer](#) [solution](#)

Evaluate $\lim_{x \rightarrow -\infty} \cos x$

Q[7]:

[hint](#) [answer](#) [solution](#)

Evaluate $\lim_{x \rightarrow \infty} x - 3x^5 + 100x^2$.

Q[8]:

[hint](#) [answer](#) [solution](#)

Evaluate $\lim_{x \rightarrow \infty} \frac{\sqrt{3x^8 + 7x^4} + 10}{x^4 - 2x^2 + 1}$.

Q[9](*):

[hint](#) [answer](#) [solution](#)

$$\lim_{x \rightarrow \infty} \left[\sqrt{x^2 + 5x} - \sqrt{x^2 - x} \right]$$

Q[10](*):

[hint](#) [answer](#) [solution](#)

Evaluate $\lim_{x \rightarrow -\infty} \frac{3x}{\sqrt{4x^2 + x} - 2x}$.

Q[11](*):

[hint](#) [answer](#) [solution](#)

Evaluate $\lim_{x \rightarrow -\infty} \frac{1 - x - x^2}{2x^2 - 7}$.

Q[12](*):

[hint](#) [answer](#) [solution](#)

Evaluate $\lim_{x \rightarrow \infty} (\sqrt{x^2 + x} - x)$

Q[13](*):

[hint](#) [answer](#) [solution](#)

Evaluate $\lim_{x \rightarrow +\infty} \frac{5x^2 - 3x + 1}{3x^2 + x + 7}$.

Q[14](*):

[hint](#) [answer](#) [solution](#)

Evaluate $\lim_{x \rightarrow +\infty} \frac{\sqrt{4x + 2}}{3x + 4}$.

Q[15](*):

[hint](#) [answer](#) [solution](#)

Evaluate $\lim_{x \rightarrow +\infty} \frac{4x^3 + x}{7x^3 + x^2 - 2}$.

Q[16]:

[hint](#) [answer](#) [solution](#)

Evaluate $\lim_{x \rightarrow -\infty} \frac{\sqrt[3]{x^2 + x} - \sqrt[4]{x^4 + 5}}{x + 1}$

Q[17](*):

[hint](#) [answer](#) [solution](#)

Evaluate $\lim_{x \rightarrow +\infty} \frac{5x^2 + 10}{3x^3 + 2x^2 + x}$.

Q[18]:

[hint](#) [answer](#) [solution](#)

Evaluate $\lim_{x \rightarrow -\infty} \frac{x + 1}{\sqrt{x^2}}$.

Q[19]:

[hint](#) [answer](#) [solution](#)

Evaluate $\lim_{x \rightarrow \infty} \frac{x + 1}{\sqrt{x^2}}$

Q[20](*):

[hint](#) [answer](#) [solution](#)

Find the limit $\lim_{x \rightarrow -\infty} \sin\left(\frac{\pi |x|}{2x}\right) + \frac{1}{x}$.

Q[21](*):

[answer](#) [solution](#)

Evaluate $\lim_{x \rightarrow -\infty} \frac{3x + 5}{\sqrt{x^2 + 5} - x}$.

Q[22](*):

[hint](#) [answer](#) [solution](#)

Evaluate $\lim_{x \rightarrow -\infty} \frac{5x + 7}{\sqrt{4x^2 + 15} - x}$

Q[23]:

[hint](#) [answer](#) [solution](#)

Evaluate $\lim_{x \rightarrow -\infty} \frac{3x^7 + x^5 - 15}{4x^2 + 32x}$.

Q[24](*):

[hint](#) [answer](#) [solution](#)

Evaluate $\lim_{n \rightarrow \infty} \left(\sqrt{n^2 + 5n} - n \right)$.

Q[25]:

[hint](#) [answer](#) [solution](#)

Evaluate $\lim_{a \rightarrow 0^+} \frac{a^2 - \frac{1}{a}}{a - 1}$.

Q[26]:

[hint](#) [answer](#) [solution](#)

Evaluate $\lim_{x \rightarrow 3} \frac{2x + 8}{\frac{1}{x-3} + \frac{1}{x^2-9}}$.

►► Stage 3

Q[27]:

[hint](#) [answer](#) [solution](#)

Give a rational function $f(x)$ with the properties that $\lim_{x \rightarrow \infty} f(x) \neq \lim_{x \rightarrow -\infty} f(x)$, and both limits are (finite) real numbers.

Q[28]:

[hint](#) [answer](#) [solution](#)

Suppose the concentration of a substance in your body t hours after injection is given by some formula $c(t)$, and $\lim_{t \rightarrow \infty} c(t) \neq 0$. What kind of substance might have been injected?

2.2▲ Asymptotes

Exercises

Jump to [HINTS](#), [ANSWERS](#), [SOLUTIONS](#) or [TABLE OF CONTENTS](#). These questions are adapted from Keshet, Chapter 1. Note that text does not provide entire solutions.

Q[1]:

[answer](#)

Consider the Michaelis-Menten kinetics where the speed of an enzyme-catalyzed reaction is given by $v = \frac{Kx}{k_n + x}$.

- Explain the statement that “when x is large there is a horizontal asymptote” and find the value of v to which that asymptote approaches.
- Determine the reaction speed when $x = k_n$ and explain why the constant k_n is sometimes called the “half-max” concentration.

Q[2]:

[answer](#)

Hill functions are sometimes used to represent a biochemical “switch,” that is a rapid transition from one state to another. Consider the functions:

$$y_1(x) = \frac{x^2}{1 + x^2}, \quad y_2(x) = \frac{x^5}{1 + x^5},$$

where $x \geq 0$.

- (a) Where do these functions intersect?
 (b) What are the asymptotes of these functions?
 (c) Which of these functions increases fastest near the origin?
 (d) Which is the sharpest “switch” and why?
-

2.3▲ Limits and continuity

Exercises

Jump to [HINTS](#), [ANSWERS](#), [SOLUTIONS](#) or [TABLE OF CONTENTS](#).

►► Stage 1

Q[1]: [hint](#) [answer](#) [solution](#)

Give an example of a function (you can write a formula, or sketch a graph) that has infinitely many infinite discontinuities.

Q[2]: [hint](#) [answer](#) [solution](#)

Suppose $f(t)$ is continuous at $t = 5$. True or false: $t = 5$ is in the domain of $f(t)$.

Q[3]: [hint](#) [answer](#) [solution](#)

Suppose $\lim_{t \rightarrow 5} f(t) = 17$, and suppose $f(t)$ is continuous at $t = 5$. True or false: $f(5) = 17$.

Q[4]: [hint](#) [answer](#) [solution](#)

Suppose $\lim_{t \rightarrow 5} f(t) = 17$. True or false: $f(5) = 17$.

Q[5]: [hint](#) [answer](#) [solution](#)

Suppose $f(x)$ and $g(x)$ are continuous at $x = 0$, and let $h(x) = \frac{xf(x)}{g^2(x) + 1}$. What is $\lim_{x \rightarrow 0^+} h(x)$?

►► Stage 2

Q[6]: [hint](#) [answer](#) [solution](#)

Find a constant k so that the function

$$a(x) = \begin{cases} x \sin\left(\frac{1}{x}\right) & \text{when } x \neq 0 \\ k & \text{when } x = 0 \end{cases}$$

is continuous at $x = 0$.

Q[7](*): [hint](#) [answer](#) [solution](#)

Describe all points for which the function is continuous: $f(x) = \frac{1}{x^2 - 1}$.

Q[8](*): [hint](#) [answer](#) [solution](#)

Describe all points for which this function is continuous: $f(x) = \frac{1}{\sqrt{x^2 - 1}}$.

Q[9](*): [hint](#) [answer](#) [solution](#)

Describe all points for which this function is continuous: $\frac{1}{\sqrt{1 + \cos(x)}}$.

Q[10](*):

[hint](#) [answer](#) [solution](#)

Describe all points for which this function is continuous: $f(x) = \frac{1}{\sin x}$.

Q[11](*):

[hint](#) [answer](#) [solution](#)

Find all values of c such that the following function is continuous at $x = c$:

$$f(x) = \begin{cases} 8 - cx & \text{if } x \leq c \\ x^2 & \text{if } x > c \end{cases}$$

Use the definition of continuity to justify your answer.

Q[12](*):

[hint](#) [answer](#) [solution](#)

Find all values of c such that the following function is continuous everywhere:

$$f(x) = \begin{cases} x^2 + c & x \geq 0 \\ \cos cx & x < 0 \end{cases}$$

Use the definition of continuity to justify your answer.

Q[13](*):

[hint](#) [answer](#) [solution](#)

Find all values of c such that the following function is continuous:

$$f(x) = \begin{cases} x^2 - 4 & \text{if } x < c \\ 3x & \text{if } x \geq c. \end{cases}$$

Use the definition of continuity to justify your answer.

Q[14](*):

[hint](#) [answer](#) [solution](#)

Find all values of c such that the following function is continuous:

$$f(x) = \begin{cases} 6 - cx & \text{if } x \leq 2c \\ x^2 & \text{if } x > 2c \end{cases}$$

Use the definition of continuity to justify your answer.

INTRODUCTION TO THE DERIVATIVE

3.1▲ Review: lines

No exercises for Section 3.1

Jump to [TABLE OF CONTENTS](#).

3.2▲ Slopes and rates of change

Exercises

Jump to [HINTS](#), [ANSWERS](#), [SOLUTIONS](#) or [TABLE OF CONTENTS](#).

►► Stage 1

Q[1]:

[answer](#) [solution](#)

Shown below is the graph $y = f(x)$. If we choose a point Q on the graph to the *left* of the y -axis, is the slope of the secant line through P and Q positive or negative? If we choose a point Q on the graph to the *right* of the y -axis, is the slope of the secant line through P and Q positive or negative?

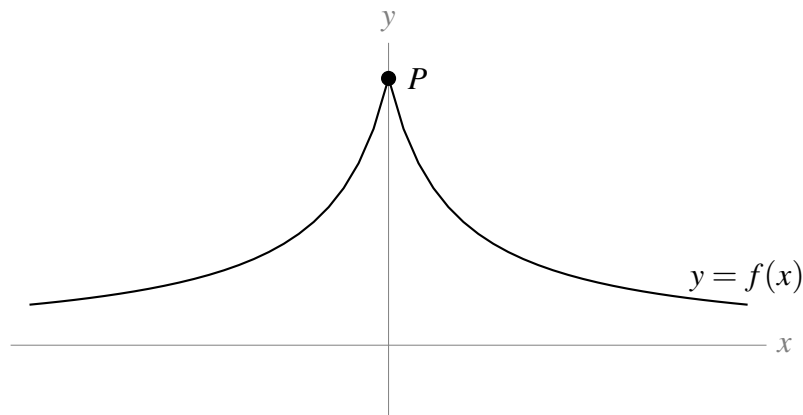

Q[2]:

[hint](#) [answer](#) [solution](#)

Shown below is the graph $y = f(x)$.

- (a) If we want the slope of the secant line through P and Q to *increase*, should we slide Q closer to P , or further away?
- (b) Which is larger, the slope of the tangent line at P , or the slope of the secant line through P and Q ?

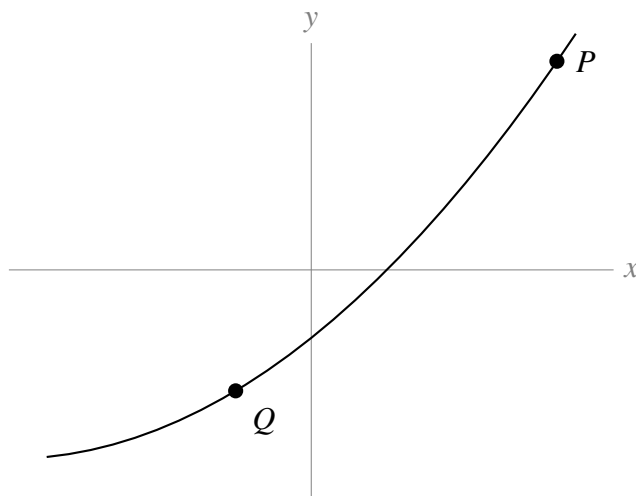

Q[3]:

[hint](#) [answer](#) [solution](#)

Group the functions below into collections whose secant lines from $x = -2$ to $x = 2$ all have the same slopes.

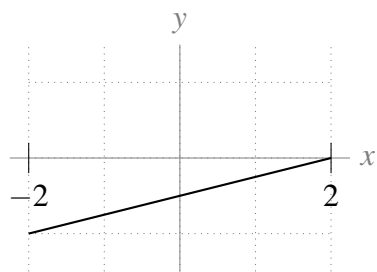

(a)

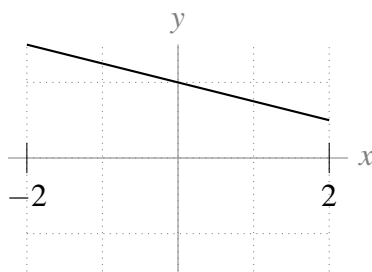

(b)

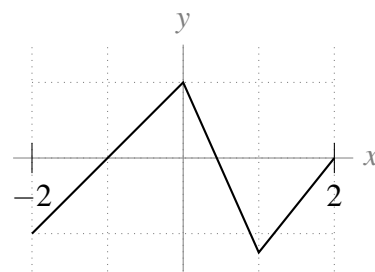

(c)

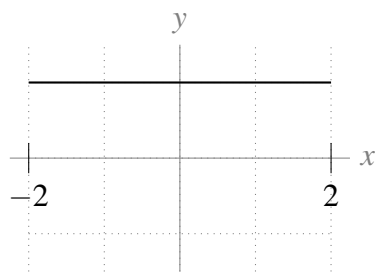

(d)

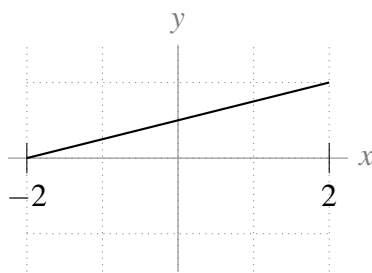

(e)

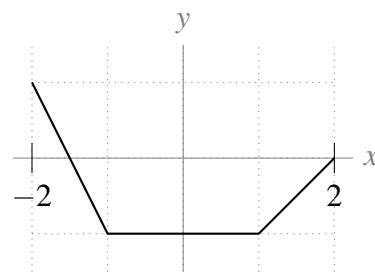

(f)

►► Stage 2

Q[4]:

[hint](#) [answer](#) [solution](#)

Give your best approximation of the slope of the tangent line to the graph below at the point $x = 5$.

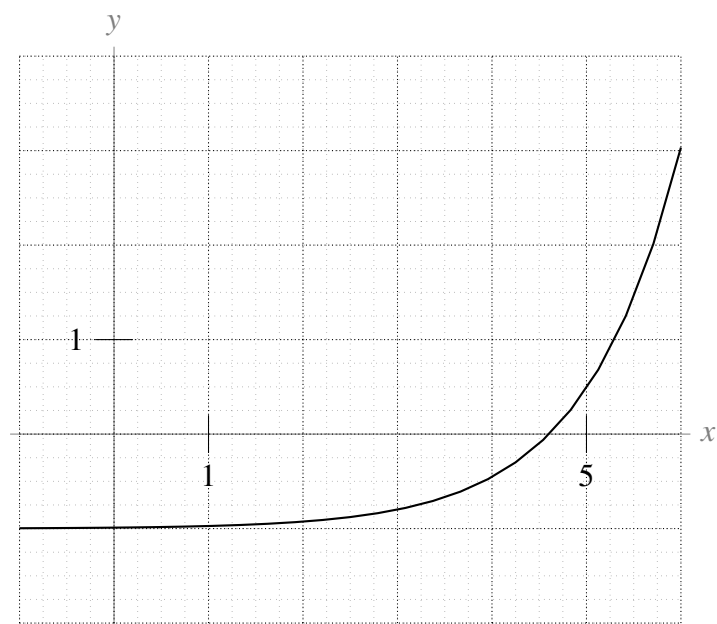

Q[5]:

[hint](#) [answer](#) [solution](#)

On the graph below, sketch the tangent line to $y = f(x)$ at P . Then, find two points Q and R on the graph so that the secant line through Q and R has the same slope as the tangent line at P .

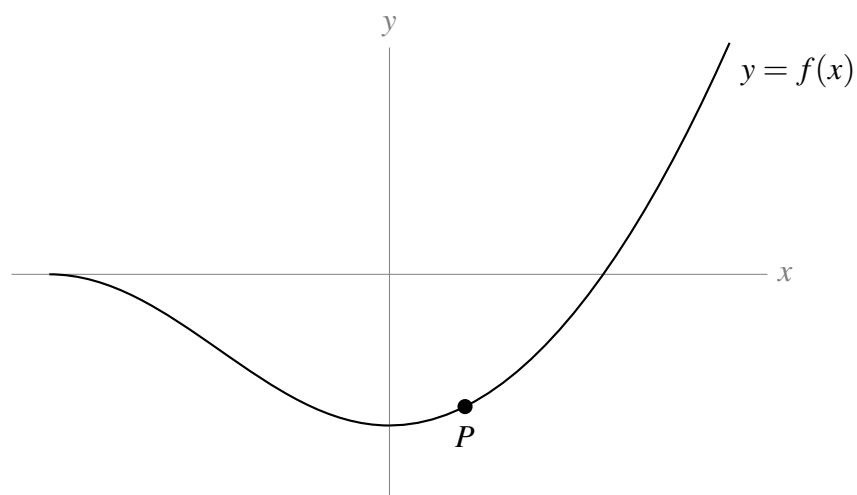

Q[6]:

[hint](#) [answer](#) [solution](#)

Mark the points where the curve shown below has a tangent line with slope 0.

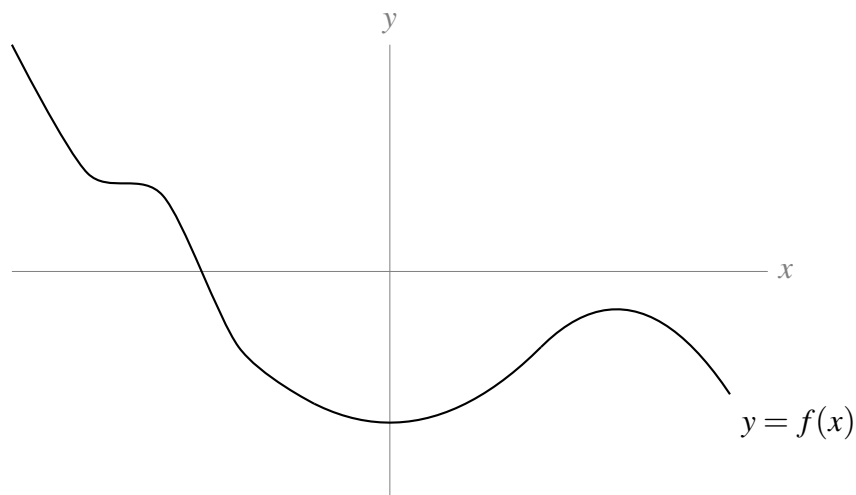

(Later on, we'll learn how these points tell us a lot about the shape of a graph.)

3.3▲ The derivative

Exercises

Jump to [HINTS](#), [ANSWERS](#), [SOLUTIONS](#) or [TABLE OF CONTENTS](#).

►► Stage 1

Q[1]:

The function $f(x)$ is shown. Select all options below that describe its derivative, $\frac{df}{dx}$:

[hint](#) [answer](#) [solution](#)

- (a) constant (b) increasing (c) decreasing
(d) always positive (e) always negative

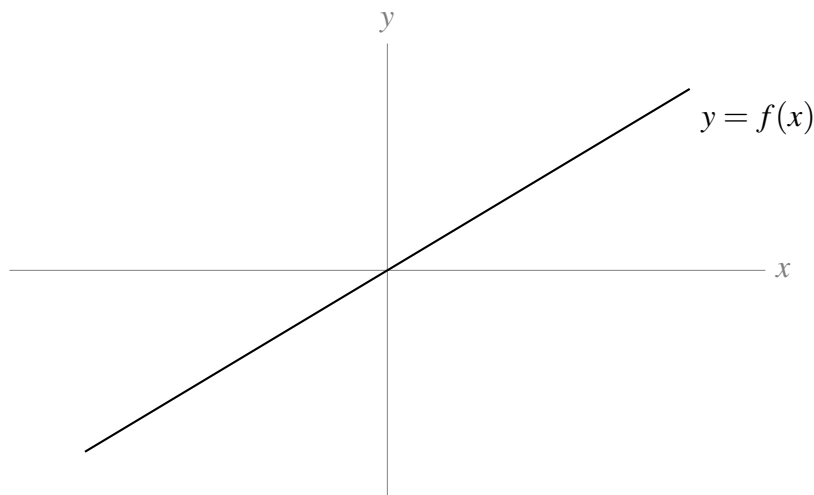

Q[2]:

The function $f(x)$ is shown. Select all options below that describe its derivative, $\frac{df}{dx}$:

[hint](#) [answer](#) [solution](#)

- (a) constant (b) increasing (c) decreasing

(d) always positive (e) always negative

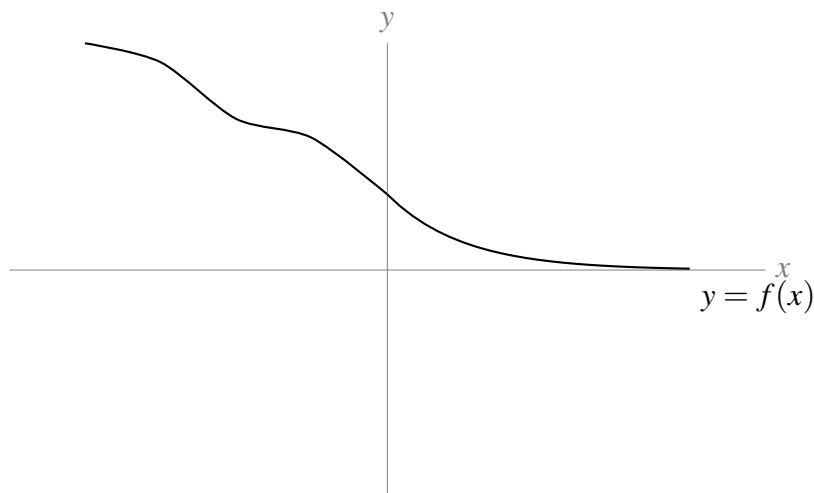

Q[3]:

The function $f(x)$ is shown. Select all options below that describe its derivative, $\frac{df}{dx}$: [hint](#) [answer](#) [solution](#)

(a) constant (b) increasing (c) decreasing
 (d) always positive (e) always negative

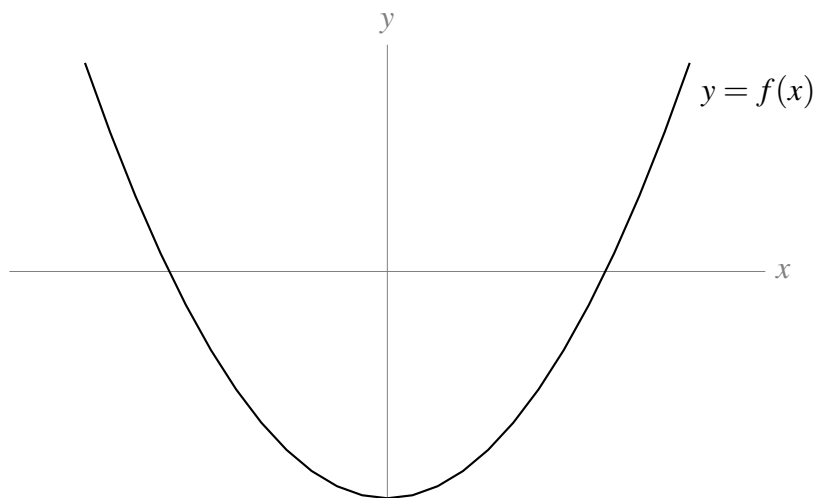

Q[4](*):

State, in terms of a limit, what it means for $f(x) = x^3$ to be differentiable at $x = 0$. [answer](#) [solution](#)

Q[5]:

For which values of x does $f'(x)$ not exist? [hint](#) [answer](#) [solution](#)

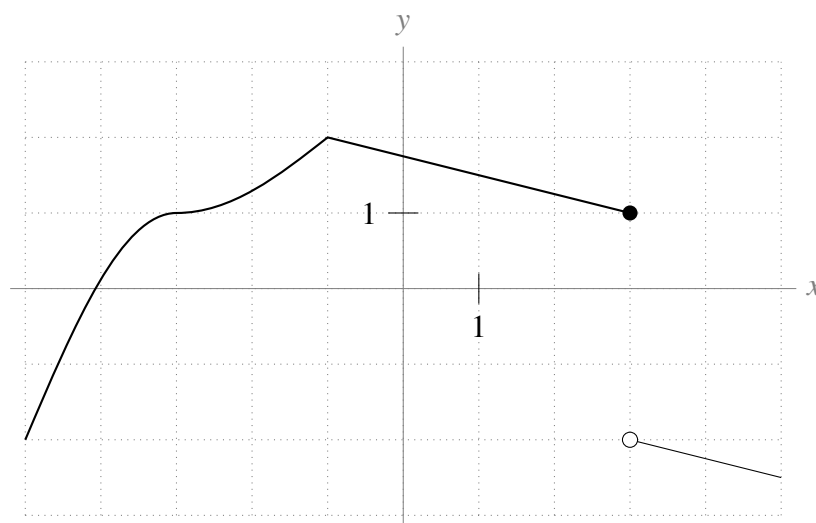

Q[6]:

[hint](#) [answer](#) [solution](#)

Suppose $f(x)$ is a function defined at $x = a$ with

$$\lim_{h \rightarrow 0^-} \frac{f(a+h) - f(a)}{h} = \lim_{h \rightarrow 0^+} \frac{f(a+h) - f(a)}{h} = 1.$$

True or false: $f'(a) = 1$.

Q[7]:

[hint](#) [answer](#) [solution](#)

Suppose $f(x)$ is a function defined at $x = a$ with

$$\lim_{x \rightarrow a^-} f'(x) = \lim_{x \rightarrow a^+} f'(x) = 1.$$

True or false: $f'(a) = 1$.

Q[8]:

[hint](#) [answer](#) [solution](#)

Suppose $s(t)$ is a function, with t measured in seconds, and s measured in metres. What are the units of $s'(t)$?

►► Stage 2

Q[9]:

[hint](#) [answer](#) [solution](#)

Use the definition of the derivative to find the equation of the tangent line to the curve $y(x) = x^3 + 5$ at the point $(1, 6)$.

Q[10]:

[hint](#) [answer](#) [solution](#)

Use the definition of the derivative to find the derivative of $f(x) = \frac{1}{x}$.

Q[11](*):

[hint](#) [answer](#) [solution](#)

Let $f(x) = x|x|$. Using the definition of the derivative, show that $f(x)$ is differentiable at $x = 0$.

Q[12](*):

[hint](#) [answer](#) [solution](#)

Use the definition of the derivative to compute the derivative of the function $f(x) = \frac{2}{x+1}$.

Q[13](*):

[answer](#) [solution](#)

Use the definition of the derivative to compute the derivative of the function $f(x) = \frac{1}{x^2+3}$.

Q[14]: [hint](#) [answer](#) [solution](#)

Use the definition of the derivative to find the slope of the tangent line to the curve

$f(x) = x \log_{10}(2x + 10)$ at the point $x = 0$.

Q[15](*): [hint](#) [answer](#) [solution](#)

Compute the derivative of $f(x) = \frac{1}{x^2}$ directly from the definition.

Q[16](*): [hint](#) [answer](#) [solution](#)

Find the values of the constants a and b for which

$$f(x) = \begin{cases} x^2 & x \leq 2 \\ ax + b & x > 2 \end{cases}$$

is differentiable everywhere.

Remark: In the text, you have already learned the derivatives of x^2 and $ax + b$. In this question, you are only asked to find the values of a and b —not to justify how you got them—so you don't have to use the definition of the derivative. However, on an exam, you might be asked to justify your answer, in which case you would show how to differentiate the two branches of $f(x)$ using the definition of a derivative.

Q[17](*): [hint](#) [answer](#) [solution](#)

Use the definition of the derivative to compute $f'(x)$ if $f(x) = \sqrt{1+x}$. Where does $f'(x)$ exist?

►► Stage 3

Q[18]: [hint](#) [answer](#) [solution](#)

Use the definition of the derivative to find the velocity of an object whose position is given by the function $s(t) = t^4 - t^2$.

Q[19](*): [hint](#) [answer](#) [solution](#)

Determine whether the derivative of following function exists at $x = 0$.

$$f(x) = \begin{cases} x \cos x & \text{if } x \geq 0 \\ \sqrt{x^2 + x^4} & \text{if } x < 0 \end{cases}$$

You must justify your answer using the definition of a derivative.

Q[20](*): [hint](#) [answer](#) [solution](#)

Determine whether the derivative of the following function exists at $x = 0$

$$f(x) = \begin{cases} x \cos x & \text{if } x \leq 0 \\ \sqrt{1+x} - 1 & \text{if } x > 0 \end{cases}$$

You must justify your answer using the definition of a derivative.

Q[21](*): [hint](#) [answer](#) [solution](#)

Determine whether the derivative of the following function exists at $x = 0$

$$f(x) = \begin{cases} x^3 - 7x^2 & \text{if } x \leq 0 \\ x^3 \cos\left(\frac{1}{x}\right) & \text{if } x > 0 \end{cases}$$

You must justify your answer using the definition of a derivative.

Q[22](*):

[hint](#) [answer](#) [solution](#)Determine whether the derivative of the following function exists at $x = 1$

$$f(x) = \begin{cases} 4x^2 - 8x + 4 & \text{if } x \leq 1 \\ (x-1)^2 \sin\left(\frac{1}{x-1}\right) & \text{if } x > 1 \end{cases}$$

You must justify your answer using the definition of a derivative.

Q[23]:

[hint](#) [answer](#) [solution](#)Sketch a function $f(x)$ with $f'(0) = -1$ that takes the following values:

x	-1	$-\frac{1}{2}$	$-\frac{1}{4}$	$-\frac{1}{8}$	0	$\frac{1}{8}$	$\frac{1}{4}$	$\frac{1}{2}$	1
f(x)	-1	$-\frac{1}{2}$	$-\frac{1}{4}$	$-\frac{1}{8}$	0	$\frac{1}{8}$	$\frac{1}{4}$	$\frac{1}{2}$	1

Remark: you can't always guess the behaviour of a function from its points, even if the points seem to be making a clear pattern.

Q[24]:

[hint](#) [answer](#) [solution](#)Let $p(x) = f(x) + g(x)$, for some functions f and g whose derivatives exist. Use limit laws and the definition of a derivative to show that $p'(x) = f'(x) + g'(x)$.

Remark: this is called the sum rule, and we'll learn more about it in Lemma 4.1.1.

Q[25]:

[hint](#) [answer](#) [solution](#)Let $f(x) = 2x$, $g(x) = x$, and $p(x) = f(x) \cdot g(x)$.(a) Find $f'(x)$ and $g'(x)$.(b) Find $p'(x)$.(c) Is $p'(x) = f'(x) \cdot g'(x)$?

In Theorem 4.1.3, you'll learn a rule for calculating the derivative of a product of two functions.

Q[26](*):

[hint](#) [answer](#) [solution](#)There are two distinct straight lines that pass through the point $(1, -3)$ and are tangent to the curve $y = x^2$. Find equations for these two lines.Remark: the point $(1, -3)$ does not lie on the curve $y = x^2$.

Q[27](*):

[hint](#) [answer](#) [solution](#)For which values of a is the function

$$f(x) = \begin{cases} 0 & x \leq 0 \\ x^a \sin \frac{1}{x} & x > 0 \end{cases}$$

differentiable at 0?

▲ Interpretations of the derivative

Exercises

Jump to [HINTS](#), [ANSWERS](#), [SOLUTIONS](#) or [TABLE OF CONTENTS](#).

►► Stage 2

Q[28]: [hint](#) [answer](#) [solution](#)
Suppose $h(t)$ gives the height at time t of the water at a dam, where the units of t are hours and the units of h are meters.

- (a) What is the physical interpretation of the slope of the secant line through the points $(0, h(0))$ and $(24, h(24))$?
- (b) What is the physical interpretation of the slope of the tangent line to the curve $y = h(t)$ at the point $(0, h(0))$?

Q[29]: [answer](#) [solution](#)
Suppose $p(t)$ is a function that gives the profit generated by selling t widgets. What is the practical interpretation of $p'(t)$?

Q[30]: [answer](#) [solution](#)
 $T(d)$ gives the temperature of water at a particular location d metres below the surface. What is the physical interpretation of $T'(d)$? Would you expect the magnitude of $T'(d)$ to be larger when d is near 0, or when d is very large?

Q[31]: [answer](#) [solution](#)
 $C(w)$ gives the calories in w grams of a particular dish. What does $C'(w)$ describe?

Q[32]: [answer](#) [solution](#)
The velocity of a moving object at time t is given by $v(t)$. What is $v'(t)$?

Q[33]: [answer](#) [solution](#)
The function $T(j)$ gives the temperature in degrees Celsius of a cup of water after j joules of heat have been added. What is $T'(j)$?

Q[34]: [answer](#) [solution](#)
A population of bacteria, left for a fixed amount of time at temperature T , grows to $P(T)$ individuals. Interpret $P'(T)$.

►► Stage 3

Q[35]: [hint](#) [answer](#) [solution](#)
You hammer a small nail into a wooden wagon wheel. $R(t)$ gives the number of rotations the nail has undergone t seconds after the wagon started to roll. Give an equation for how quickly the nail is rotating, measured in degrees per second.

Q[36]: [hint](#) [answer](#) [solution](#)
A population of bacteria, left for a fixed amount of time at temperature T , grows to $P(T)$ individuals. There is one ideal temperature where the bacteria population grows largest, and the closer the sample is to that temperature, the larger the population is (unless the temperature is so extreme that it causes all the bacteria to die by freezing or boiling). How will $P'(T)$ tell you whether you are colder or hotter than the ideal temperature?

3.4▲ Higher order derivatives**Exercises**

Jump to [HINTS](#), [ANSWERS](#), [SOLUTIONS](#) or [TABLE OF CONTENTS](#).

►► Stage 3

Q[1]:

[hint](#) [answer](#) [solution](#)

A function $f(x)$ satisfies $f'(x) < 0$ and $f''(x) > 0$ over (a, b) . Which of the following curves below might represent $y = f(x)$?

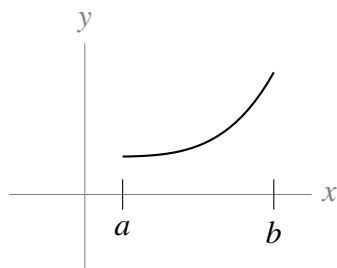

(i)

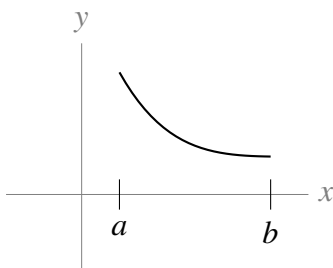

(ii)

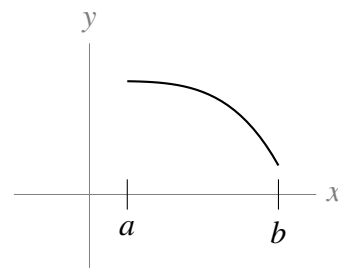

(iii)

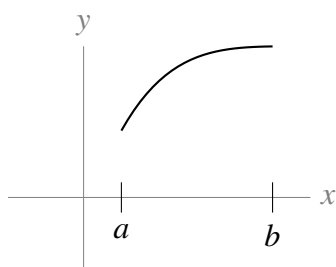

(iv)

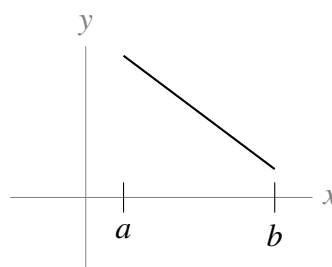

(v)

3.5▲ Derivatives of exponential functions

Exercises

Jump to [HINTS](#), [ANSWERS](#), [SOLUTIONS](#) or [TABLE OF CONTENTS](#).

►► Stage 1

Q[1]:

[hint](#) [answer](#) [solution](#)

Match the curves in the graph to the following functions:

$$(a) y = \left(\frac{1}{2}\right)^x \quad (b) y = 1^x \quad (c) y = 2^x \quad (d) y = 2^{-x} \quad (e) y = 3^x$$

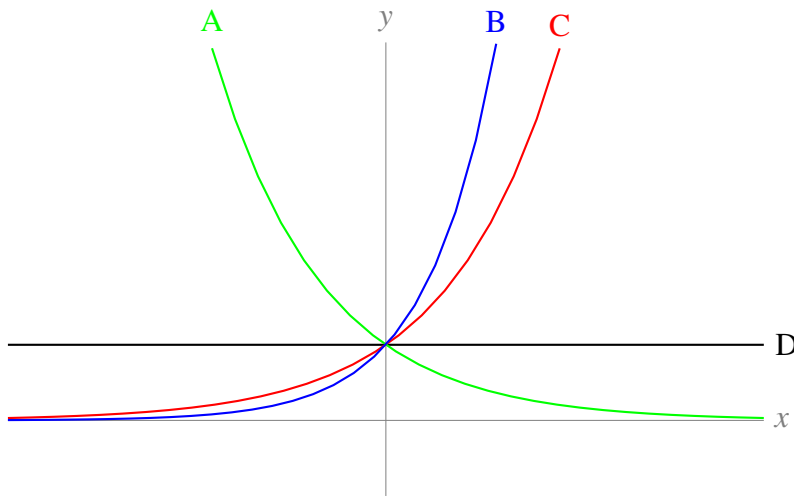

Q[2]:

[hint](#) [answer](#) [solution](#)

The graph below shows an exponential function $f(x) = a^x$ and its derivative $f'(x)$. Choose all the options that describe the constant a .

- (a) $a < 0$ (b) $a > 0$ (c) $a < 1$ (d) $a > 1$ (e) $a < e$ (f) $a > e$

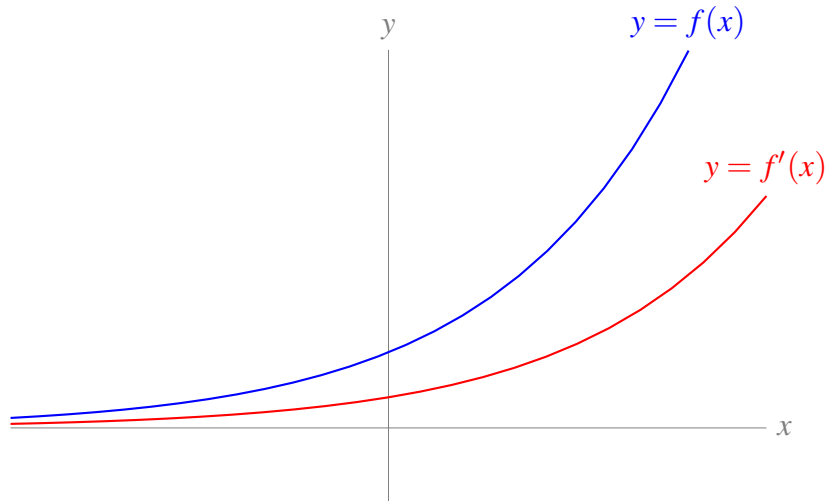

Q[3]:

[hint](#) [answer](#) [solution](#)

True or false: $\frac{d}{dx}\{e^x\} = xe^{x-1}$

Q[4]:

[hint](#) [answer](#) [solution](#)

A population of bacteria is described by $P(t) = 100e^{0.2t}$, for $0 \leq t \leq 10$. Over this time period, is the population increasing or decreasing?

Q[5]:

[hint](#) [answer](#) [solution](#)

What is the 180th derivative of the function $f(x) = e^x$?

►► Stage 3

Q[6]:

[hint](#) [answer](#) [solution](#)

Which of the following functions describe a straight line?

- (a) $y = e^{3\log x} + 1$ (b) $2y + 5 = e^{3+\log x}$ (c) $y = e^{2x} + 4$ (d) $y = e^{\log x} 3^e + \log 2$

COMPUTING DERIVATIVES

4.1▲ Arithmetic of derivatives

Exercises

Jump to [HINTS](#), [ANSWERS](#), [SOLUTIONS](#) or [TABLE OF CONTENTS](#).

►► Stage 1

Q[1]: [hint](#) [answer](#) [solution](#)

True or false: $\frac{d}{dx}\{f(x) + g(x)\} = f'(x) + g'(x)$ when f and g are differentiable functions.

Q[2]: [hint](#) [answer](#) [solution](#)

True or false: $\frac{d}{dx}\{f(x)g(x)\} = f'(x)g'(x)$ when f and g are differentiable functions.

Q[3]: [hint](#) [answer](#) [solution](#)

True or false: $\frac{d}{dx} \left\{ \frac{f(x)}{g(x)} \right\} = \frac{f'(x)}{g(x)} - \frac{f(x)g'(x)}{g^2(x)}$ when f and g are differentiable functions.

Q[4]: [hint](#) [answer](#) [solution](#)

Let f be a differentiable function. Use at least three different rules to differentiate $g(x) = 3f(x)$ in different ways, and verify that they all give the same answer.

►► Stage 2

Q[5]: [hint](#) [answer](#) [solution](#)

Differentiate $f(x) = 3x^2 + 4x^{1/2}$ for $x > 0$.

Q[6]: [hint](#) [answer](#) [solution](#)

Let $f(x) = 2^x$. What is $f^{(n)}(x)$, if n is a whole number?

Q[7]: [hint](#) [answer](#) [solution](#)

Use the product rule to differentiate $f(x) = (2x + 5)(8\sqrt{x} - 9x)$.

Q[8](*): [hint](#) [answer](#) [solution](#)

Find the equation of the tangent line to the graph of $y = x^3$ at $x = \frac{1}{2}$.

Q[9](*): [hint](#) [answer](#) [solution](#)

A particle moves along the x -axis so that its position at time t is given by $x = t^3 - 4t^2 + 1$.

(a) At $t = 2$, what is the particle's speed? That is, what is the absolute value of its velocity?

(b) At $t = 2$, in what direction is the particle moving?

(c) At $t = 2$, is the particle's speed increasing or decreasing?

Q[10](*): [answer](#) [solution](#)

Calculate and simplify the derivative of $\frac{2x-1}{2x+1}$

Q[11]: [hint](#) [answer](#) [solution](#)

What is the slope of the graph $y = \left(\frac{3x+1}{3x-2}\right)^2$ when $x = 1$?

►► Stage 3

Q[12]: [hint](#) [answer](#) [solution](#)

Let $g(x) = f(x)e^x$, for a differentiable function $f(x)$. Give a simplified formula for $g'(x)$.

Functions of the form $g(x)$ are relatively common. If you remember this formula, you can save yourself some time when you need to differentiate them.

Q[13]: [hint](#) [answer](#) [solution](#)

A town is founded in the year 2000. After t years, it has had $b(t)$ births and $d(t)$ deaths. Nobody enters or leaves the town except by birth or death (whoa). Give an expression for the rate the population of the town is growing.

Q[14](*): [answer](#) [solution](#)

Find all points on the curve $y = 3x^2$ where the tangent line passes through $(2, 9)$.

Q[15](*): [hint](#) [answer](#) [solution](#)

Evaluate $\lim_{y \rightarrow 0} \left(\frac{\sqrt{100180+y} - \sqrt{100180}}{y} \right)$ by interpreting the limit as a derivative.

Q[16]: [hint](#) [answer](#) [solution](#)

A rectangle is growing. At time $t = 0$, it is a square with side length 1 metre. Its width increases at a constant rate of 2 metres per second, and its length increases at a constant rate of 5 metres per second. How fast is its area increasing at time $t > 0$?

Q[17]: [hint](#) [answer](#) [solution](#)

Let $f(x) = x^2g(x)$ for some differentiable function $g(x)$. What is $f'(0)$?

Q[18]: [answer](#) [solution](#)

Verify that differentiating $f(x) = \frac{g(x)}{h(x)}$ using the quotient rule gives the same answer as differentiating $f(x) = \frac{g(x)}{k(x)} \cdot \frac{k(x)}{h(x)}$ using the product rule and the quotient rule, when $k(x) \neq 0$.

Q[19](*):

[hint](#) [answer](#) [solution](#)Find constants a, b so that the following function is differentiable:

$$f(x) = \begin{cases} ax^2 + b & x \leq 1 \\ e^x & x > 1 \end{cases}$$

Q[20]:

[hint](#) [answer](#) [solution](#)Let $g(x) = f(x)e^x$. In Question 12, Section 3.5, we learned that $g'(x) = [f(x) + f'(x)]e^x$.(a) What is $g''(x)$?(b) What is $g'''(x)$?(c) Based on your answers above, guess a formula for $g^{(4)}(x)$. Check it by differentiating.

Q[21](*):

[hint](#) [answer](#) [solution](#)

$$f(x) = e^{x+x^2} \qquad h(x) = 1 + x + \frac{3}{2}x^2$$

(a) Find the first and second derivatives of both functions

(b) Evaluate both functions and their first and second derivatives at 0.

(c) Show that for all $x > 0$, $f(x) > h(x)$.

Remark: for some applications, we only need to know that a function is “big enough.” Since $f(x)$ is a difficult function to evaluate, it may be useful in some circumstances to know that it is bigger than $h(x)$ when x is positive.

►► Using the arithmetic of derivatives - examples

Exercises

Jump to [HINTS](#), [ANSWERS](#), [SOLUTIONS](#) or [TABLE OF CONTENTS](#).

►► Stage 1

Q[22]:

[hint](#) [answer](#) [solution](#)

Spot and correct the error(s) in the following calculation.

$$\begin{aligned} f(x) &= \frac{2x}{x+1} \\ f'(x) &= \frac{2(x+1) + 2x}{(x+1)^2} \\ &= \frac{2(x+1)}{(x+1)^2} \\ &= \frac{2}{x+1} \end{aligned}$$

Q[23]:

[hint](#) [answer](#) [solution](#)True or false: $\frac{d}{dx}\{2^x\} = x2^{x-1}$.

►► Stage 2

Q[24]: [hint](#) [answer](#) [solution](#)

Find the derivative of $f(x) = \frac{e^x}{2x}$.

Q[25]: [hint](#) [answer](#) [solution](#)

Differentiate $f(x) = e^{2x}$.

Q[26]: [hint](#) [answer](#) [solution](#)

Differentiate $f(x) = e^{a+x}$, where a is a constant.

Q[27]: [hint](#) [answer](#) [solution](#)

For which values of x is the function $f(x) = xe^x$ increasing?

Q[28]: [hint](#) [answer](#) [solution](#)

Suppose the position of a particle at time t is given by $s(t) = \frac{e^t}{t^2 + 1}$. Find the acceleration of the particle ($s''(t)$) at time $t = 1$.

Q[29]: [hint](#) [answer](#) [solution](#)

Differentiate $f(x) = (e^x + 1)(e^x - 1)$.

Q[30]: [hint](#) [answer](#) [solution](#)

A particle's position is given by

$$s(t) = t^2 e^t.$$

When is the particle moving in the negative direction?

Q[31]: [hint](#) [answer](#) [solution](#)

Let $f(x) = ax^{15}$ for some constant a . Which value of a results in $f^{(15)}(x) = 3$?

Q[32]: [hint](#) [answer](#) [solution](#)

Differentiate $f(x) = \frac{2}{3}x^6 + 5x^4 + 12x^2 + 9$ and factor the result.

Q[33]: [hint](#) [answer](#) [solution](#)

Differentiate $s(t) = 3t^4 + 5t^3 - \frac{1}{t}$.

Q[34]: [hint](#) [answer](#) [solution](#)

Differentiate $x(y) = \left(2y + \frac{1}{y}\right) \cdot y^3$.

Q[35]: [hint](#) [answer](#) [solution](#)

Differentiate $T(x) = \frac{\sqrt{x} + 1}{x^2 + 3}$.

Q[36](*) [answer](#) [solution](#)

Compute the derivative of $\left(\frac{7x + 2}{x^2 + 3}\right)$.

Q[37]: [hint](#) [answer](#) [solution](#)

What is $f'(0)$, when $f(x) = (3x^3 + 4x^2 + x + 1)(2x + 5)$?

Q[38]: [hint](#) [answer](#) [solution](#)

Differentiate $f(x) = \frac{3x^3 + 1}{x^2 + 5x}$.

Q[39](*) [answer](#) [solution](#)

Compute the derivative of $\left(\frac{3x^2 + 5}{2 - x}\right)$

Q[40](*): [answer](#) [solution](#)

Compute the derivative of $\left(\frac{2 - x^2}{3x^2 + 5}\right)$.

Q[41](*): [answer](#) [solution](#)

Compute the derivative of $\left(\frac{2x^3 + 1}{x + 2}\right)$.

Q[42](*): [hint](#) [answer](#) [solution](#)

For what values of x does the derivative of $\frac{\sqrt{x}}{1 - x^2}$ exist? Explain your answer.

Q[43]: [hint](#) [answer](#) [solution](#)

Differentiate $f(x) = (3\sqrt[5]{x} + 15\sqrt[3]{x} + 8)(3x^2 + 8x - 5)$.

Q[44]: [hint](#) [answer](#) [solution](#)

Differentiate $f(x) = \frac{(x^2 + 5x + 1)(\sqrt{x} + \sqrt[3]{x})}{x}$.

►► Stage 3

Q[45]: [hint](#) [answer](#) [solution](#)

Let $f(x) = ax^3 + bx^2 + cx + d$, where a, b, c , and d are nonzero constants. What is the smallest integer n so that $\frac{d^n f}{dx^n} = 0$ for all x ?

Q[46](*): [hint](#) [answer](#) [solution](#)

Let $f(x) = x|x|$.

(a) Show that $f(x)$ is differentiable at $x = 0$, and find $f'(0)$.

(b) Find the second derivative of $f(x)$. Explicitly state, with justification, the point(s) at which $f''(x)$ does not exist, if any.

Q[47](*): [hint](#) [answer](#) [solution](#)

Find an equation of a line that is tangent to both of the curves $y = x^2$ and $y = x^2 - 2x + 2$ (at different points).

Q[48](*): [hint](#) [answer](#) [solution](#)

Find all lines that are tangent to both of the curves $y = x^2$ and $y = -x^2 + 2x - 5$. Illustrate your answer with a sketch.

Q[49](*): [hint](#) [answer](#) [solution](#)

Evaluate $\lim_{x \rightarrow 2} \left(\frac{x^{2015} - 2^{2015}}{x - 2}\right)$.

4.2▲ Trigonometric functions and their derivatives

Exercises

Jump to [HINTS](#), [ANSWERS](#), [SOLUTIONS](#) or [TABLE OF CONTENTS](#).

►► Stage 1

Q[1]: [hint](#) [answer](#) [solution](#)
Graph sine and cosine on the same axes, from $x = -2\pi$ to $x = 2\pi$. Mark the points where $\sin x$ has a horizontal tangent. What do these points correspond to, on the graph of cosine?

Q[2]: [hint](#) [answer](#) [solution](#)
Graph sine and cosine on the same axes, from $x = -2\pi$ to $x = 2\pi$. Mark the points where $\sin x$ has a tangent line of maximum (positive) slope. What do these points correspond to, on the graph of cosine?

Q[3]: [hint](#) [answer](#) [solution](#)
The height of a particle at time t seconds is given by $h(t) = -\cos t$. Is the particle speeding up or slowing down at $t = 1$?

Q[4]: [hint](#) [answer](#) [solution](#)
The height of a particle at time t seconds is given by $h(t) = t^3 - t^2 - 5t + 10$. Is the particle's motion getting faster or slower at $t = 1$?

Q[5]: [hint](#) [answer](#) [solution](#)
Which statements below are true, and which false?

(a) $\frac{d^4}{dx^4} \sin x = \sin x$

(b) $\frac{d^4}{dx^4} \cos x = \cos x$

(c) $\frac{d^4}{dx^4} \tan x = \tan x$

►► Stage 2

Q[6]: [hint](#) [answer](#) [solution](#)
Differentiate $f(x) = \sin x + \cos x + \tan x$.

Q[7]: [hint](#) [answer](#) [solution](#)
For which values of x does the function $f(x) = \sin x + \cos x$ have a horizontal tangent?

Q[8]: [hint](#) [answer](#) [solution](#)
Differentiate $f(x) = \sin^2 x + \cos^2 x$.

Q[9]: [hint](#) [answer](#) [solution](#)
Differentiate $f(x) = 2 \sin x \cos x$.

Q[10]: [answer](#) [solution](#)
Differentiate $f(x) = e^x \cot x$.

Q[11]: [hint](#) [answer](#) [solution](#)
Differentiate $f(x) = \frac{2 \sin x + 3 \tan x}{\cos x + \tan x}$

Q[12]: [answer](#) [solution](#)
Differentiate $f(x) = \frac{5 \sec x + 1}{e^x}$.

Q[13]: [answer](#) [solution](#)

Differentiate $f(x) = (e^x + \cot x)(5x^6 - \csc x)$.

Q[14]:

[hint](#) [answer](#) [solution](#)

Differentiate $f(\theta) = \sin\left(\frac{\pi}{2} - \theta\right)$.

Q[15]:

[hint](#) [answer](#) [solution](#)

Differentiate $f(x) = \sin(-x) + \cos(-x)$.

Q[16]:

[hint](#) [answer](#) [solution](#)

Differentiate $s(\theta) = \frac{\cos \theta + \sin \theta}{\cos \theta - \sin \theta}$.

Q[17](*):

[hint](#) [answer](#) [solution](#)

Find the values of the constants a and b for which

$$f(x) = \begin{cases} \cos(x) & x \leq 0 \\ ax + b & x > 0 \end{cases}$$

is differentiable everywhere.

Q[18](*):

[answer](#) [solution](#)

Find the equation of the line tangent to the graph of $y = \cos(x) + 2x$ at $x = \frac{\pi}{2}$.

►► Stage 3

Q[19](*):

[hint](#) [answer](#) [solution](#)

Evaluate $\lim_{x \rightarrow 2015} \left(\frac{\cos(x) - \cos(2015)}{x - 2015} \right)$.

Q[20](*):

[hint](#) [answer](#) [solution](#)

Evaluate $\lim_{x \rightarrow \pi/3} \left(\frac{\cos(x) - 1/2}{x - \pi/3} \right)$.

Q[21](*):

[hint](#) [answer](#) [solution](#)

Evaluate $\lim_{x \rightarrow \pi} \left(\frac{\sin(x)}{x - \pi} \right)$.

Q[22]:

[hint](#) [answer](#) [solution](#)

Show how you can use the quotient rule to find the derivative of tangent, if you already know the derivatives of sine and cosine.

Q[23](*):

[hint](#) [answer](#) [solution](#)

The derivative of the function

$$f(x) = \begin{cases} ax + b & \text{for } x < 0 \\ \frac{6\cos x}{2 + \sin x + \cos x} & \text{for } x \geq 0 \end{cases}$$

exists for all x . Determine the values of the constants a and b .

Q[24](*):

[hint](#) [answer](#) [solution](#)

For which values of x does the derivative of $f(x) = \tan x$ exist?

Q[25](*):

[answer](#) [solution](#)

For what values of x does the derivative of $\frac{10\sin(x)}{x^2 + x - 6}$ exist? Explain your answer.

Q[26](*): [answer](#) [solution](#)

For what values of x does the derivative of $\frac{x^2 + 6x + 5}{\sin(x)}$ exist? Explain your answer.

Q[27](*): [answer](#) [solution](#)

Find the equation of the line tangent to the graph of $y = \tan(x)$ at $x = \frac{\pi}{4}$.

Q[28](*): [answer](#) [solution](#)

Find the equation of the line tangent to the graph of $y = \sin(x) + \cos(x) + e^x$ at $x = 0$.

Q[29]: [answer](#) [solution](#)

For which values of x does the function $f(x) = e^x \sin x$ have a horizontal tangent line?

Q[30]:

This question has been deleted, because it does not fit nicely with Math 100 assessable content.

►► Application of Understanding

Q[31](*): [hint](#) [answer](#) [solution](#)

Differentiate the function

$$h(x) = \sin(|x|)$$

and give the domain where the derivative exists.

Q[32](*): [hint](#) [answer](#) [solution](#)

For the function

$$f(x) = \begin{cases} 0 & x \leq 0 \\ \frac{\sin(x)}{\sqrt{x}} & x > 0 \end{cases}$$

which of the following statements is correct?

- i. f is undefined at $x = 0$.
- ii. f is neither continuous nor differentiable at $x = 0$.
- iii. f is continuous but not differentiable at $x = 0$.
- iv. f is differentiable but not continuous at $x = 0$.
- v. f is both continuous and differentiable at $x = 0$.

Q[33](*): [hint](#) [answer](#) [solution](#)

Evaluate $\lim_{x \rightarrow 0} \frac{\sin x^{27} + 2x^5 e^{x^{99}}}{\sin^5 x}$.

4.3▲ The chain rule

Exercises

Jump to [HINTS](#), [ANSWERS](#), [SOLUTIONS](#) or [TABLE OF CONTENTS](#).

►► Stage 1

Q[1]:

[hint](#) [answer](#) [solution](#)

Suppose the amount of kelp in a harbour depends on the number of urchins. Urchins eat kelp: when there are more urchins, there is less kelp, and when there are fewer urchins, there is more kelp.

Suppose further that the number of urchins in the harbour depends on the number of otters, who find urchins extremely tasty: the more otters there are, the fewer urchins there are.

Let O , U , and K be the populations of otters, urchins, and kelp, respectively.

(a) Is $\frac{dK}{dU}$ positive or negative?

(b) Is $\frac{dU}{dO}$ positive or negative?

(c) Is $\frac{dK}{dO}$ positive or negative?

Remark: An urchin barren is an area where unchecked sea urchin grazing has decimated the kelp population, which in turn causes the other species that shelter in the kelp forests to leave. Introducing otters to urchin barrens is one intervention to increase biodiversity. A short video with a more complex view of otters and urchins in Canadian waters is available on YouTube:

<https://youtu.be/ASJ82wyHisE>

Q[2]:

[hint](#) [answer](#) [solution](#)

Suppose A , B , C , D , and E are functions describing an interrelated system, with the following signs: $\frac{dA}{dB} > 0$, $\frac{dB}{dC} > 0$, $\frac{dC}{dD} < 0$, and $\frac{dD}{dE} > 0$. Is $\frac{dA}{dE}$ positive or negative?

►► Stage 2

Q[3]:

[hint](#) [answer](#) [solution](#)

Evaluate the derivative of $f(x) = \cos(5x + 3)$.

Q[4]:

[hint](#) [answer](#) [solution](#)

Evaluate the derivative of $f(x) = (x^2 + 2)^5$.

Q[5]:

[hint](#) [answer](#) [solution](#)

Evaluate the derivative of $T(k) = (4k^4 + 2k^2 + 1)^{17}$.

Q[6]:

[hint](#) [answer](#) [solution](#)

Evaluate the derivative of $f(x) = \sqrt{\frac{x^2 + 1}{x^2 - 1}}$.

Q[7]:

[hint](#) [answer](#) [solution](#)

Evaluate the derivative of $f(x) = e^{\cos(x^2)}$.

Q[8](*):

[hint](#) [answer](#) [solution](#)

Evaluate $f'(2)$ if $f(x) = g(x/h(x))$, $h(2) = 2$, $h'(2) = 3$, $g'(1) = 4$.

Q[9](*):

[hint](#) [answer](#) [solution](#)

Find the derivative of $e^{x \cos(x)}$.

Q[10](*):

[hint](#) [answer](#) [solution](#)

Evaluate $f'(x)$ if $f(x) = e^{x^2 + \cos x}$.

Q[11](*):

[hint](#) [answer](#) [solution](#)

Evaluate $f'(x)$ if $f(x) = \sqrt{\frac{x-1}{x+2}}$.

Q[12](*):

[hint](#) [answer](#) [solution](#)

Differentiate the function

$$f(x) = \frac{1}{x^2} + \sqrt{x^2 - 1}$$

and give the domain where the derivative exists.

Q[13](*):

[answer](#) [solution](#)

Evaluate the derivative of $f(x) = \frac{\sin 5x}{1+x^2}$

Q[14]:

[hint](#) [answer](#) [solution](#)

Evaluate the derivative of $f(x) = \sec(e^{2x+7})$.

Q[15]:

[hint](#) [answer](#) [solution](#)

Find the tangent line to the curve $y = (\tan^2 x + 1)(\cos^2 x)$ at the point $x = \frac{\pi}{4}$.

Q[16]:

[hint](#) [answer](#) [solution](#)

The position of a particle at time t is given by $s(t) = e^{t^3-7t^2+8t}$. For which values of t is the velocity of the particle zero?

Q[17]:

[hint](#) [answer](#) [solution](#)

What is the slope of the tangent line to the curve $y = \tan(e^{x^2})$ at the point $x = 1$?

Q[18](*):

[hint](#) [answer](#) [solution](#)

Differentiate $y = e^{4x} \tan x$. You do not need to simplify your answer.

Q[19](*):

[hint](#) [answer](#) [solution](#)

Evaluate the derivative of the following function at $x = 1$: $f(x) = \frac{x^3}{1+e^{3x}}$.

Q[20](*):

[hint](#) [answer](#) [solution](#)

Differentiate $e^{\sin^2(x)}$.

Q[21](*):

[hint](#) [answer](#) [solution](#)

Compute the derivative of $y = \sin(e^{5x})$

Q[22](*):

[hint](#) [answer](#) [solution](#)

Find the derivative of $e^{\cos(x^2)}$.

Q[23](*):

[hint](#) [answer](#) [solution](#)

Compute the derivative of $y = \cos(x^2 + \sqrt{x^2 + 1})$

Q[24](*):

[hint](#) [answer](#) [solution](#)

Evaluate the derivative.

$$y = (1+x^2)\cos^2 x$$

Q[25](*):

[answer](#) [solution](#)

Evaluate the derivative.

$$y = \frac{e^{3x}}{1+x^2}$$

Q[26](*): [answer](#) [solution](#)

Find $g'(2)$ if $g(x) = x^3h(x^2)$, where $h(4) = 2$ and $h'(4) = -2$.

Q[27](*): [hint](#) [answer](#) [solution](#)

At what points (x, y) does the curve $y = xe^{-(x^2-1)/2}$ have a horizontal tangent?

Q[28]: [hint](#) [answer](#) [solution](#)

A particle starts moving at time $t = 1$, and its position thereafter is given by

$$s(t) = \sin\left(\frac{1}{t}\right).$$

When is the particle moving in the negative direction?

Q[29]: [hint](#) [answer](#) [solution](#)

Compute the derivative of $f(x) = \frac{e^x}{\cos^3(5x-7)}$.

Q[30](*): [hint](#) [answer](#) [solution](#)

Evaluate $\frac{d}{dx} \{xe^{2x} \cos 4x\}$.

►► Stage 3

Q[31]: [hint](#) [answer](#) [solution](#)

A particle moves along the Cartesian plane from time $t = -\pi/2$ to time $t = \pi/2$. The x -coordinate of the particle at time t is given by $x = \cos t$, and the y -coordinate is given by $y = \sin t$, so the particle traces a curve in the plane. When does the tangent line to that curve have slope -1 ?

Q[32](*): [hint](#) [answer](#) [solution](#)

Show that, for all $x > 0$, $e^{x+x^2} > 1+x$.

Q[33]: [hint](#) [answer](#) [solution](#)

We know that $\sin(2x) = 2\sin x \cos x$. What other trig identity can you derive from this, using differentiation?

Q[34]: [hint](#) [answer](#) [solution](#)

Evaluate the derivative of $f(x) = \sqrt[3]{\frac{e^{\csc x^2}}{\sqrt{x^3 - 9\tan x}}}$. You do not have to simplify your answer.

Q[35]: [hint](#) [answer](#) [solution](#)

Suppose a particle is moving in the Cartesian plane over time. For any real number $t \geq 0$, the coordinate of the particle at time t is given by $(\sin t, \cos^2 t)$.

(a) Sketch a graph of the curve traced by the particle in the plane by plotting points, and describe how the particle moves along it over time.

(b) What is the slope of the curve traced by the particle at time $t = \frac{10\pi}{3}$?

4.4▲ Logarithmic differentiation

Exercises

Jump to [HINTS](#), [ANSWERS](#), [SOLUTIONS](#) or [TABLE OF CONTENTS](#). Reminder: in these notes, we use $\log x$ to mean $\log_e x$, which is also commonly written elsewhere as $\ln x$.

►► Stage 1

Q[1]: [hint](#) [answer](#) [solution](#)

The volume in decibels (dB) of a sound is given by the formula:

$$V(P) = 10 \log_{10} \left(\frac{P}{S} \right)$$

where P is the intensity of the sound and S is the intensity of a standard baseline sound. (That is: S is some constant.)

How much noise will ten speakers make, if each speaker produces 3dB of noise? What about one hundred speakers?

Q[2]: [hint](#) [answer](#) [solution](#)

An investment of \$1000 with an interest rate of 5% per year grows to

$$A(t) = 1000e^{t/20}$$

dollars after t years. When will the investment double?

Q[3]: [hint](#) [answer](#) [solution](#)

Which of the following expressions, if any, is equivalent to $\log(\cos^2 x)$?

- (a) $2 \log(\cos x)$ (b) $2 \log |\cos x|$ (c) $\log^2(\cos x)$ (d) $\log(\cos x^2)$

►► Stage 2

Q[4]: [hint](#) [answer](#) [solution](#)

Differentiate $f(x) = \log(10x)$.

Q[5]: [hint](#) [answer](#) [solution](#)

Differentiate $f(x) = \log(x^2)$.

Q[6]: [hint](#) [answer](#) [solution](#)

Differentiate $f(x) = \log(x^2 + x)$.

Q[7]: [hint](#) [answer](#) [solution](#)

Differentiate $f(x) = \log_{10} x$.

Q[8](*): [answer](#) [solution](#)

Find the derivative of $y = \frac{\log x}{x^3}$.

Q[9]: [hint](#) [answer](#) [solution](#)

Evaluate $\frac{d}{d\theta} \log(\sec \theta)$.

Q[10]: [hint](#) [answer](#) [solution](#)

Differentiate the function $f(x) = e^{\cos(\log x)}$.

Q[11](*):

[hint](#) [answer](#) [solution](#)

Evaluate the derivative. You do not need to simplify your answer.

$$y = \log(x^2 + \sqrt{x^4 + 1})$$

Q[12](*):

[hint](#) [answer](#) [solution](#)Differentiate $\sqrt{-\log(\cos x)}$.

Q[13](*):

[hint](#) [answer](#) [solution](#)Calculate and simplify the derivative of $\log(x + \sqrt{x^2 + 4})$.

Q[14](*):

[hint](#) [answer](#) [solution](#)Evaluate the derivative of $g(x) = \log(e^{x^2} + \sqrt{1 + x^4})$.

Q[15](*):

[hint](#) [answer](#) [solution](#)Evaluate the derivative of the following function at $x = 1$: $g(x) = \log\left(\frac{2x-1}{2x+1}\right)$.

Q[16]:

[hint](#) [answer](#) [solution](#)Evaluate the derivative of the function $f(x) = \log\left(\sqrt{\frac{(x^2 + 5)^3}{x^4 + 10}}\right)$.

Q[17]:

[hint](#) [answer](#) [solution](#)Evaluate $f'(2)$ if $f(x) = \log(g(xh(x)))$, $h(2) = 2$, $h'(2) = 3$, $g(4) = 3$, $g'(4) = 5$.

Q[18](*):

[hint](#) [answer](#) [solution](#)

Differentiate the function

$$g(x) = \pi^x + x^\pi.$$

Q[19]:

[hint](#) [answer](#) [solution](#)Differentiate $f(x) = x^x$.

Q[20](*):

[hint](#) [answer](#) [solution](#)Find $f'(x)$ if $f(x) = x^x + \log_{10} x$.

Q[21]:

[hint](#) [answer](#) [solution](#)Differentiate $f(x) = \sqrt[4]{\frac{(x^4 + 12)(x^4 - x^2 + 2)}{x^3}}$.

Q[22]:

[hint](#) [answer](#) [solution](#)Differentiate $f(x) = (x + 1)(x^2 + 1)^2(x^3 + 1)^3(x^4 + 1)^4(x^5 + 1)^5$.

Q[23]:

[hint](#) [answer](#) [solution](#)Differentiate $f(x) = \left(\frac{5x^2 + 10x + 15}{3x^4 + 4x^3 + 5}\right) \left(\frac{1}{10(x+1)}\right)$.

Q[24](*):

[hint](#) [answer](#) [solution](#)Let $f(x) = (\cos x)^{\sin x}$, with domain $0 < x < \frac{\pi}{2}$. Find $f'(x)$.

Q[25](*):

[hint](#) [answer](#) [solution](#)Find the derivative of $(\tan(x))^x$, when x is in the interval $(0, \pi/2)$.

Q[26](*): [hint](#) [answer](#) [solution](#)
 Find $f'(x)$ if $f(x) = (x^2 + 1)^{(x^2+1)}$

Q[27](*): [hint](#) [answer](#) [solution](#)
 Differentiate $f(x) = (x^2 + 1)^{\sin(x)}$.

Q[28]: [hint](#) [answer](#) [solution](#)
 Evaluate $\frac{d^3}{dx^3} \{\log(5x^2 - 12)\}$.

Q[29](*): [hint](#) [answer](#) [solution](#)
 Let $f(x) = x^{\cos^3(x)}$, with domain $(0, \infty)$. Find $f'(x)$.

Q[30](*): [hint](#) [answer](#) [solution](#)
 Differentiate $f(x) = (3 + \sin(x))^{x^2-3}$.

►► Stage 3

Q[31]: [hint](#) [answer](#) [solution](#)
 Let $f(x)$ and $g(x)$ be differentiable functions, with $f(x) > 0$. Evaluate $\frac{d}{dx} \{ [f(x)]^{g(x)} \}$.

Q[32]: [hint](#) [answer](#) [solution](#)
 Let $f(x)$ be a function whose range includes only positive numbers. Show that the curves $y = f(x)$ and $y = \log(f(x))$ have horizontal tangent lines at the same values of x .

4.5▲ Implicit differentiation

Exercises

Jump to [HINTS](#), [ANSWERS](#), [SOLUTIONS](#) or [TABLE OF CONTENTS](#).

►► Stage 1

Q[1]: [hint](#) [answer](#) [solution](#)
 If we implicitly differentiate $x^2 + y^2 = 1$, we get the equation $2x + 2yy' = 0$. In the step where we differentiate y^2 to obtain $2yy'$, which rule(s) below are we using?

- (a) power rule (b) chain rule (c) quotient rule
 (d) derivatives of exponential functions

Q[2]: [hint](#) [answer](#) [solution](#)
 Using the picture below, estimate $\frac{dy}{dx}$ at the three points where the curve crosses the y -axis.

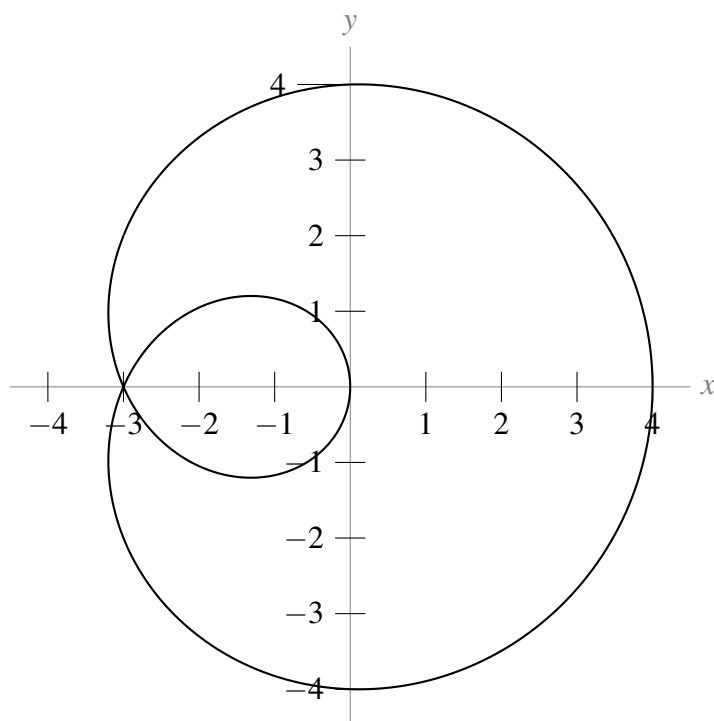

Remark: for this curve, one value of x may correspond to multiple values of y . So, we cannot express this curve as $y = f(x)$ for any function x . This is one typical situation where we might use implicit differentiation.

Q[3]:

[hint](#) [answer](#) [solution](#)

Consider the unit circle, formed by all points (x, y) that satisfy $x^2 + y^2 = 1$.

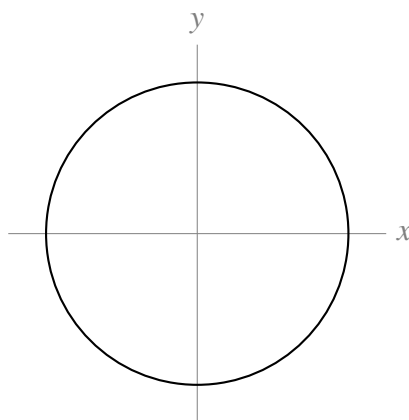

- Is there a function $f(x)$ so that $y = f(x)$ completely describes the unit circle? That is, so that the points (x, y) that make the equation $y = f(x)$ true are exactly the same points that make the equation $x^2 + y^2 = 1$ true?
- Is there a function $f'(x)$ so that $y = f'(x)$ completely describes the slope of the unit circle? That is, so that for every point (x, y) on the unit circle, the slope of the tangent line to the circle at that point is given by $f'(x)$?
- Use implicit differentiation to find an expression for $\frac{dy}{dx}$. Simplify until the expression is a function in terms of x only (not y), or explain why this is impossible.

Q[4]:

[hint](#) [answer](#) [solution](#)

Find the mistake(s) in the following work, and provide a corrected answer.

Suppose $-14x^2 + 2xy + y^2 = 1$. We find $\frac{d^2y}{dx^2}$ at the point $(1, 3)$. Differentiating implicitly:

$$-28x + 2y + 2xy' + 2yy' = 0$$

Plugging in $x = 1, y = 3$:

$$-28 + 6 + 2y' + 6y' = 0$$

$$y' = \frac{11}{4}$$

Differentiating:

$$y'' = 0$$

►► Stage 2

Q[5](*):

[hint](#) [answer](#) [solution](#)Find $\frac{dy}{dx}$ if $xy + e^x + e^y = 1$.

Q[6](*):

[hint](#) [answer](#) [solution](#)If $e^y = xy^2 + x$, compute $\frac{dy}{dx}$.

Q[7](*):

[hint](#) [answer](#) [solution](#)If $x^2 \tan(\pi y/4) + 2x \log(y) = 16$, then find y' at the points where $y = 1$.

Q[8]:

[hint](#) [answer](#) [solution](#)

Suppose a curve is defined implicitly by

$$x^2 + x + y = \sin(xy)$$

What is $\frac{d^2y}{dx^2}$ at the point $(0, 0)$?

Q[9](*):

[answer](#) [solution](#)If $x^3 + y^4 = \cos(x^2 + y)$ compute $\frac{dy}{dx}$.

Q[10](*):

[hint](#) [answer](#) [solution](#)If $x^2 e^y + 4x \cos(y) = 5$, then find y' at the points where $y = 0$.

Q[11]:

[hint](#) [answer](#) [solution](#)The unit circle consists of all point $x^2 + y^2 = 1$. Give an expression for $\frac{d^2y}{dx^2}$ in terms of y .

Q[12](*):

[answer](#) [solution](#)If $x^2 + y^2 = \sin(x + y)$ compute $\frac{dy}{dx}$.

Q[13](*):

[hint](#) [answer](#) [solution](#)If $x^2 \cos(y) + 2xe^y = 8$, then find y' at the points where $y = 0$.

Q[14]: [hint](#) [answer](#) [solution](#)

At what points on the ellipse $x^2 + 3y^2 = 1$ is the tangent line parallel to the line $y = x$?

Q[15](*): [hint](#) [answer](#) [solution](#)

For the curve defined by the equation $\sqrt{xy} = x^2y - 2$, find the slope of the tangent line at the point $(1, 4)$.

Q[16](*): [hint](#) [answer](#) [solution](#)

If $x^2y^2 + x \sin(y) = 4$, find $\frac{dy}{dx}$.

Q[17]: [hint](#) [answer](#) [solution](#)

Let $f(x) = (\log x - 1)x$. Evaluate $f'''(x)$.

►► Stage 3

Q[18](*): [hint](#) [answer](#) [solution](#)

If $x^2 + (y + 1)e^y = 5$, then find y' at the points where $y = 0$.

Q[19]: [answer](#) [solution](#)

For what values of x do the circle $x^2 + y^2 = 1$ and the ellipse $x^2 + 3y^2 = 1$ have parallel tangent lines?

Q[20](*): [hint](#) [answer](#) [solution](#)

The equation $x^3y + y^3 = 10x$ defines y implicitly as a function of x near the point $(1, 2)$.

(a) Compute y' at this point.

(b) It can be shown that y'' is negative when $x = 1$. Use this fact and your answer to (a) to make a sketch showing the relationship of the curve to its tangent line at $(1, 2)$.

4.6▲ Inverse functions

No exercises for Section 4.6

Jump to [TABLE OF CONTENTS](#).

4.7▲ Inverse trigonometric functions and their derivatives

Exercises

Jump to [HINTS](#), [ANSWERS](#), [SOLUTIONS](#) or [TABLE OF CONTENTS](#).

►► Stage 1

Q[1]: [hint](#) [answer](#) [solution](#)

Give the domains of each of the following functions.

(a) $f(x) = \arcsin(\cos x)$ (b) $g(x) = \operatorname{arccsc}(\cos x)$ (c) $h(x) = \sin(\arccos x)$

Q[2]: [hint](#) [answer](#) [solution](#)
 A particle starts moving at time $t = 10$, and it bobs up and down, so that its height at time $t \geq 10$ is given by $\cos t$. True or false: the particle has height 1 at time $t = \arccos(1)$.

Q[3]: [hint](#) [answer](#) [solution](#)
 The curve $y = f(x)$ is shown below, for some function f . Restrict f to the largest possible interval containing 0 over which it is one-to-one, and sketch the curve $y = f^{-1}(x)$.

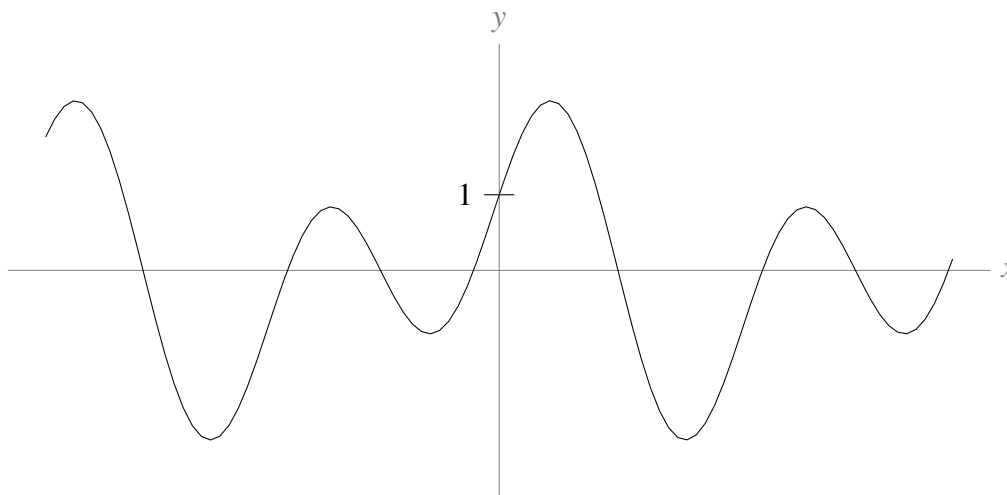

Q[4]: [hint](#) [answer](#) [solution](#)
 Let a be some constant. Where does the curve $y = ax + \cos x$ have a horizontal tangent line?

Q[5]: [hint](#) [answer](#) [solution](#)
 Define a function $f(x) = \arcsin x + \operatorname{arccsc} x$. What is the domain of $f(x)$? Where is $f(x)$ differentiable?

►► Stage 2

Q[6]: [hint](#) [answer](#) [solution](#)
 Differentiate $f(x) = \arcsin\left(\frac{x}{3}\right)$. What is the domain of $f(x)$?

Q[7]: [hint](#) [answer](#) [solution](#)
 Differentiate $f(t) = \frac{\operatorname{arccost}}{t^2 - 1}$. What is the domain of $f(t)$?

Q[8]: [hint](#) [answer](#) [solution](#)
 Differentiate $f(x) = \operatorname{arcsec}(-x^2 - 2)$. What is the domain of $f(x)$?

Q[9]: [hint](#) [answer](#) [solution](#)
 Differentiate $f(x) = \frac{1}{a} \arctan\left(\frac{x}{a}\right)$, where a is a nonzero constant. What is the domain of $f(x)$?

Q[10]: [hint](#) [answer](#) [solution](#)
 Differentiate $f(x) = x \arcsin x + \sqrt{1 - x^2}$. What is the domain of $f(x)$?

Q[11]: [hint](#) [answer](#) [solution](#)
 For which values of x is the tangent line to $y = \arctan(x^2)$ horizontal?

Q[12]: [hint](#) [answer](#) [solution](#)

Evaluate $\frac{d}{dx}\{\arcsin x + \arccos x\}$.

Q[13](*):

[hint](#) [answer](#) [solution](#)

Find the derivative of $y = \arcsin\left(\frac{1}{x}\right)$.

Q[14]:

[hint](#) [answer](#) [solution](#)

Evaluate $\frac{d^2}{dx^2}\{\arctan x\}$.

Q[15](*):

[answer](#) [solution](#)

Find the derivative of $y = \arctan\left(\frac{1}{x}\right)$.

Q[16](*):

[answer](#) [solution](#)

Calculate and simplify the derivative of $(1 + x^2)\arctan x$.

Q[17]:

[hint](#) [answer](#) [solution](#)

Show that $\frac{d}{dx}\{\sin(\arctan(x))\} = (x^2 + 1)^{-3/2}$.

Q[18]:

[hint](#) [answer](#) [solution](#)

Show that $\frac{d}{dx}\{\cot(\arcsin(x))\} = \frac{-1}{x^2\sqrt{1-x^2}}$.

Q[19](*):

[hint](#) [answer](#) [solution](#)

Determine all points on the curve $y = \arcsin x$ where the tangent line is parallel to the line $y = 2x + 9$.

Q[20]:

[hint](#) [answer](#) [solution](#)

For which values of x does the function $f(x) = \arctan(\csc x)$ have a horizontal tangent line?

►► Stage 3

Q[21](*):

[hint](#) [answer](#) [solution](#)

Let $f(x) = x + \cos x$, and let $g(y) = f^{-1}(y)$ be the inverse function. Determine $g'(y)$.

Q[22](*):

[hint](#) [answer](#) [solution](#)

$f(x) = 2x - \sin(x)$ is one-to-one. Find $(f^{-1})'(\pi - 1)$.

Q[23](*):

[hint](#) [answer](#) [solution](#)

$f(x) = e^x + x$ is one-to-one. Find $(f^{-1})'(e + 1)$.

Q[24]:

[hint](#) [answer](#) [solution](#)

Differentiate $f(x) = [\sin x + 2]^{\operatorname{arcsec} x}$. What is the domain of this function?

Q[25]:

[hint](#) [answer](#) [solution](#)

Suppose you can't remember whether the derivative of arcsine is $\frac{1}{\sqrt{1-x^2}}$ or $\frac{1}{\sqrt{x^2-1}}$. Describe how the domain of arcsine suggests that one of these is wrong.

Q[26]:

[hint](#) [answer](#) [solution](#)

Evaluate $\lim_{x \rightarrow 1} \left((x-1)^{-1} \left(\arctan x - \frac{\pi}{4} \right) \right)$.

Q[27]:

[hint](#) [answer](#) [solution](#)

Suppose $f(2x+1) = \frac{5x-9}{3x+7}$. Evaluate $f^{-1}(7)$.

Q[28]:

[hint](#) [answer](#) [solution](#)

Suppose $f^{-1}(4x - 1) = \frac{2x + 3}{x + 1}$. Evaluate $f(0)$.

Q[29]:

[hint](#) [answer](#) [solution](#)

Suppose a curve is defined implicitly by

$$\arcsin(x + 2y) = x^2 + y^2.$$

Solve for y' in terms of x and y .

RELATED RATES

Exercises

Jump to [HINTS](#), [ANSWERS](#), [SOLUTIONS](#) or [TABLE OF CONTENTS](#).

►► Stage 1

Q[1]:

[hint](#) [answer](#) [solution](#)

Suppose the quantities P and Q are related by the formula $P = Q^3$. P and Q are changing with respect to time, t . Given this information, which of the following are problems you could solve?

- Given $\frac{dP}{dt}(0)$, find $\frac{dQ}{dt}(0)$. (Remember: the notation $\frac{dP}{dt}(0)$ means the derivative of P with respect to t at the time $t = 0$.)
- Given $\frac{dP}{dt}(0)$ and the value of Q when $t = 0$, find $\frac{dQ}{dt}(0)$.
- Given $\frac{dQ}{dt}(0)$, find $\frac{dP}{dt}(0)$.
- Given $\frac{dQ}{dt}(0)$ and the value of P when $t = 0$, find $\frac{dP}{dt}(0)$.

►► Stage 2

For problems 2 through 4, the relationship between several variables is explicitly given. Use this information to relate their rates of change.

Q[2](*):

[hint](#) [answer](#) [solution](#)

A point is moving on the unit circle $\{(x, y) : x^2 + y^2 = 1\}$ in the xy -plane. At the point $\left(\frac{2}{\sqrt{5}}, \frac{1}{\sqrt{5}}\right)$, its y -coordinate is increasing at rate 3. What is the rate of change of its x -coordinate?

Q[3](*):

[hint](#) [answer](#) [solution](#)

The quantities P , Q and R are functions of time and are related by the equation $R = PQ$. Assume that P is increasing instantaneously at the rate of 8% per year and that Q is decreasing instantaneously

at the rate of 2% per year. That is, $\frac{P'}{P} = 0.08$ and $\frac{Q'}{Q} = -0.02$. Determine the percentage rate of change for R .

Q[4](*):

[hint](#) [answer](#) [solution](#)

Three quantities, F , P and Q all depend upon time t and are related by the equation

$$F = \frac{P}{Q}$$

- (a) Assume that at a particular moment in time $P = 25$ and P is increasing at the instantaneous rate of 5 units/min. At the same moment, $Q = 5$ and Q is increasing at the instantaneous rate of 1 unit/min. What is the instantaneous rate of change in F at this moment?
- (b) Assume that at another moment in time P is increasing at the instantaneous rate of 10% and Q is decreasing at the instantaneous rate 5%. What can you conclude about the rate of change of F at this moment?

For Questions 5 through 9, look for a way to use the Pythagorean Theorem.

Q[5](*):

[hint](#) [answer](#) [solution](#)

Two particles move in the Cartesian plane. Particle A travels on the x -axis starting at $(10,0)$ and moving towards the origin with a speed of 2 units per second. Particle B travels on the y -axis starting at $(0,12)$ and moving towards the origin with a speed of 3 units per second. What is the rate of change of the distance between the two particles when particle A reaches the point $(4,0)$?

Q[6](*):

[hint](#) [answer](#) [solution](#)

Two particles A and B are placed on the Cartesian plane at $(0,0)$ and $(3,0)$ respectively. At time 0, both start to move in the $+y$ direction. Particle A moves at 3 units per second, while B moves at 2 units per second. How fast is the distance between the particles changing when particle A is at a distance of 5 units from B .

Q[7](*):

[hint](#) [answer](#) [solution](#)

Ship A is 400 miles directly south of Hawaii and is sailing south at 20 miles/hour. Ship B is 300 miles directly east of Hawaii and is sailing west at 15 miles/hour. At what rate is the distance between the ships changing?

Q[8](*):

[hint](#) [answer](#) [solution](#)

Two tall sticks are vertically planted into the ground, separated by a distance of 30 cm. We simultaneously put two snails at the base of each stick. The two snails then begin to climb their respective sticks. The first snail is moving with a speed of 25 cm per minute, while the second snail is moving with a speed of 15 cm per minute. What is the rate of change of the distance between the two snails when the first snail reaches 100 cm above the ground?

Q[9](*):

[hint](#) [answer](#) [solution](#)

A 20m long extension ladder leaning against a wall starts collapsing in on itself at a rate of 2m/s, while the foot of the ladder remains a constant 5m from the wall. How fast is the ladder moving down the wall after 3.5 seconds?

For Questions 10 through 14, look for tricks from trigonometry.

Q[10]:

[hint](#) [answer](#) [solution](#)

A watering trough has a cross section shaped like an isosceles trapezoid. The trough is 2 metres long, 50 cm high, 1 metre wide at the top, and 60 cm wide at the bottom.

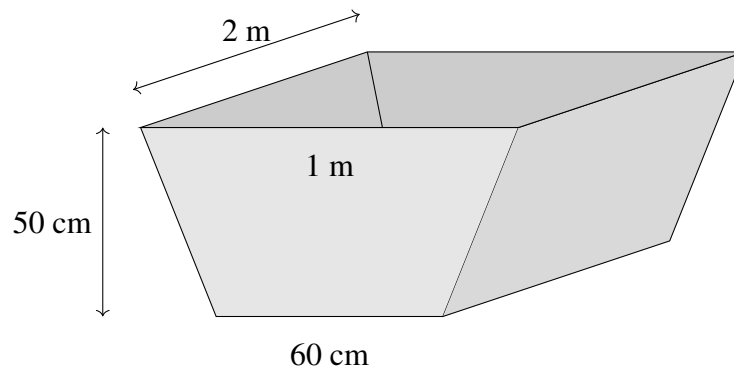

A pig is drinking water from the trough at a rate of 3 litres per minute. When the height of the water is 25 cm, how fast is the height decreasing?

Q[11]:

[hint](#) [answer](#) [solution](#)

A tank is 5 metres long, and has a trapezoidal cross section with the dimensions shown below.

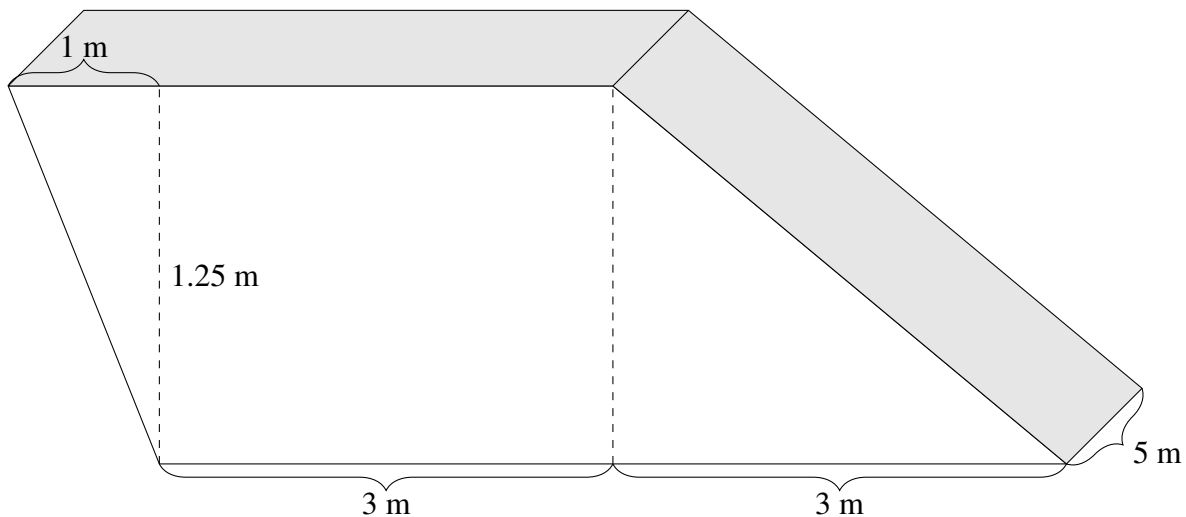

A hose is filling the tank up at a rate of one litre per second. How fast is the height of the water increasing when the water is 10 centimetres deep?

Q[12]:

[hint](#) [answer](#) [solution](#)

A rocket is blasting off, 2 kilometres away from you. You and the rocket start at the same height.

The height of the rocket in kilometres, t hours after liftoff, is given by

$$h(t) = 61750t^2$$

How fast (in radians per second) is your line of sight rotating to keep looking at the rocket, one minute after liftoff?

Q[13](*):

[hint](#) [answer](#) [solution](#)

A high speed train is traveling at 2 km/min along a straight track. The train is moving away from a movie camera which is located 0.5 km from the track.

- How fast is the distance between the train and the camera increasing when they are 1.3 km apart?
- Assuming that the camera is always pointed at the train, how fast (in radians per min) is the camera rotating when the train and the camera are 1.3 km apart?

Q[14]:

[hint](#) [answer](#) [solution](#)

A clock has a minute hand that is 10 cm long, and an hour hand that is 5 cm long. Let D be the distance between the tips of the two hands. How fast is D decreasing at 4:00?

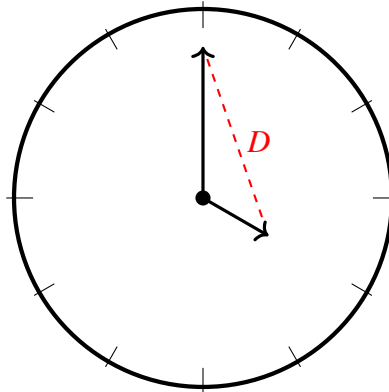

For Questions 15 through 20, you'll need to know formulas for volume or area.

Q[15](*):

[hint](#) [answer](#) [solution](#)

Find the rate of change of the area of the annulus $\{(x,y) : r^2 \leq x^2 + y^2 \leq R^2\}$. (i.e. the points inside the circle of radius R but outside the circle of radius r) if

$$R = 3 \text{ cm}, r = 1 \text{ cm}, \frac{dR}{dt} = 2 \frac{\text{cm}}{\text{s}}, \text{ and } \frac{dr}{dt} = 7 \frac{\text{cm}}{\text{s}}.$$

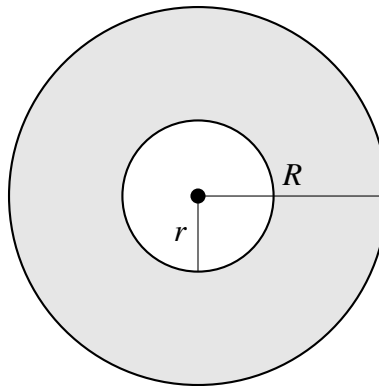

Q[16]:

[hint](#) [answer](#) [solution](#)

Two spheres are centred at the same point. The radius R of the bigger sphere at time t is given by $R(t) = 10 + 2t$, while the radius r of the smaller sphere is given by $r(t) = 6t, t \geq 0$. How fast is the volume between the spheres (inside the big sphere and outside the small sphere) changing when the bigger sphere has a radius twice as large as the smaller?

Q[17]:

[hint](#) [answer](#) [solution](#)

You attach two sticks together at their ends, and stick the other ends in the mud. One stick is 150 cm long, and the other is 200 cm.

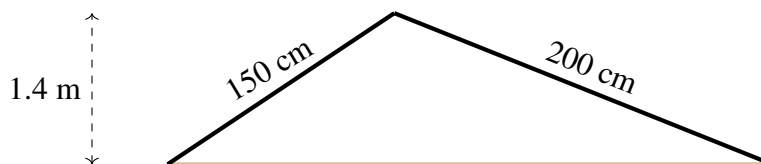

The structure starts out being 1.4 metres high at its peak, but the sticks slide, and the height decreases at a constant rate of three centimetres per minute. How quickly is the area of the triangle (formed by the two sticks and the level ground) changing when the height of the structure is 120 cm?

Q[18]:

[hint](#) [answer](#) [solution](#)

The circular lid of a salt shaker has radius 8. There is a cut-out to allow the salt to pour out of the lid, and a door that rotates around to cover the cut-out. The door is a quarter-circle of radius 7 cm. The cut-out has the shape of a quarter-annulus with outer radius 6 cm and inner radius 1 cm. If the uncovered area of the cut-out is $A \text{ cm}^2$, then the salt flows out at $\frac{1}{5}A \text{ cm}^3$ per second.

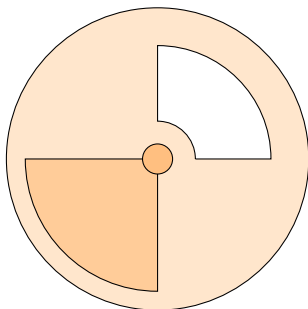

salt shaker lid
cut-out uncovered

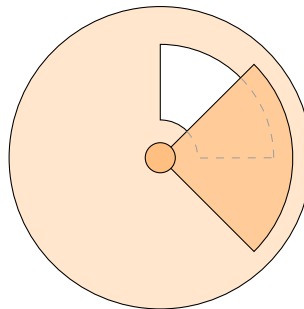

salt shaker lid
cut-out partially covered

Recall: an annulus is the set of points inside one circle and outside another, like a flat doughnut (see Question 15).

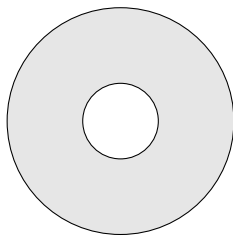

annulus

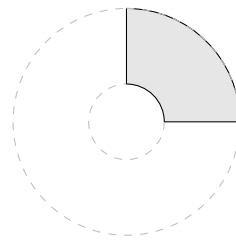

quarter annulus

While pouring out salt, you spin the door around the lid at a constant rate of $\frac{\pi}{6}$ radians per second, covering more and more of the cut-out. When exactly half of the cut-out is covered, how fast is the flow of salt changing?

Q[19]:

[hint](#) [answer](#) [solution](#)

A cylindrical sewer pipe with radius 1 metre has a vertical rectangular door that slides in front of it to block the flow of water, as shown below. If the uncovered area of the pipe is $A \text{ m}^2$, then the flow of water through the pipe is $\frac{1}{5}A$ cubic metres per second.

The door slides over the pipe, moving vertically at a rate of 1 centimetre per second. How fast is the flow of water changing when the door covers the top 25 centimetres of the pipe?

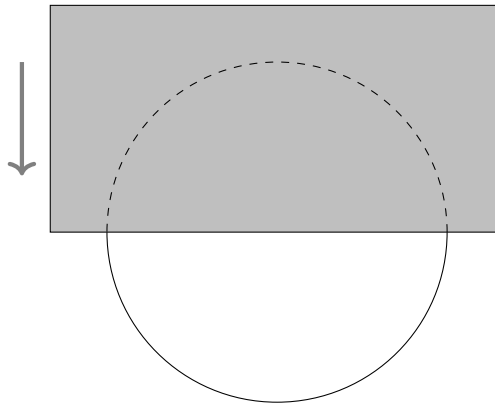

Q[20]:

[hint](#) [answer](#) [solution](#)

A martini glass is shaped like a cone, with top diameter 10 cm and side length 10 cm.

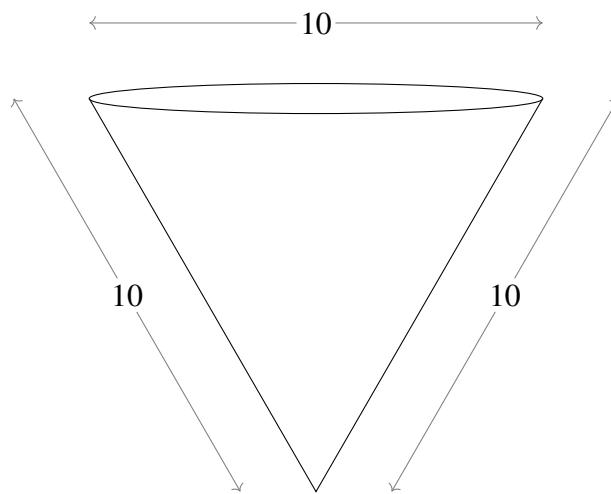

When the liquid in the glass is 7 cm high, it is evaporating at a rate of 5 mL per minute. How fast is the height of the liquid decreasing?

►► Stage 3

Q[21]:

[hint](#) [answer](#) [solution](#)

A floating buoy is anchored to the bottom of a river. As the river flows, the buoy is pulled in the direction of flow until its 2-metre rope is taut. A sensor at the anchor reads the angle θ between the rope and the riverbed, as shown in the diagram below. This data is used to measure the depth D of water in the river, which depends on time.

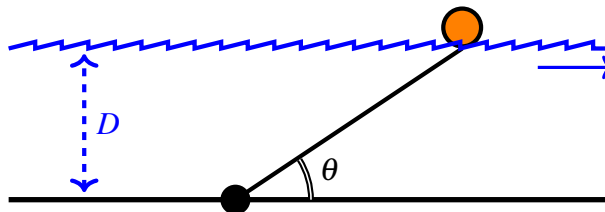

(a) If $\theta = \frac{\pi}{4}$ and $\frac{d\theta}{dt} = 0.25 \frac{\text{rad}}{\text{hr}}$, how fast is the depth D of the water changing?

(b) A measurement shows $\frac{d\theta}{dt} = 0$, but $\frac{dD}{dt} \neq 0$. Under what circumstances does this occur?

(c) Another measurement shows $\frac{d\theta}{dt} > 0$, but $\frac{dD}{dt} < 0$. Under what circumstances does this occur?

Q[22]:

[hint](#) [answer](#) [solution](#)

A point is moving in the xy -plane along the quadrilateral shown below.

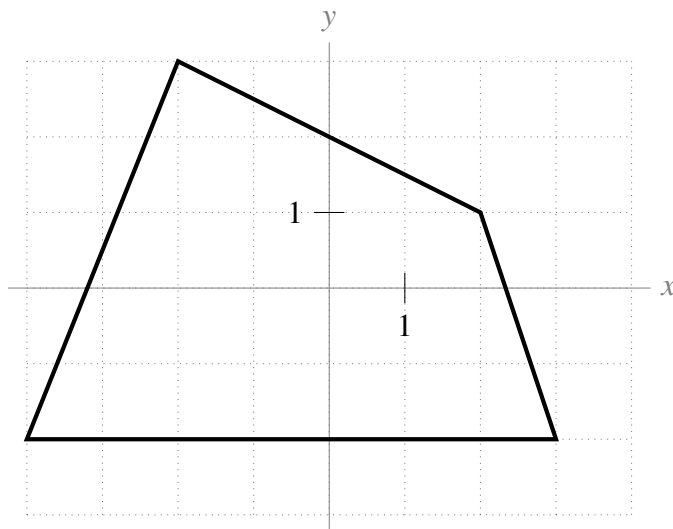

- (a) When the point is at $(0, -2)$, it is moving to the right. An observer stationed at the origin must turn at a rate of one radian per second to keep looking directly at the point. How fast is the point moving?
- (b) When the point is at $(0, 2)$, its x -coordinate is increasing at a rate of one unit per second. How fast is its y -coordinate changing? How fast is the point moving?

Q[23]:

[hint](#) [answer](#) [solution](#)

You have a cylindrical water bottle 20 cm high, filled with water. Its cross section is a circle of radius 5. You slowly smooch the sides, so the cross section becomes an ellipse with major axis (widest part) $2a$ and minor axis (skinniest part) $2b$.

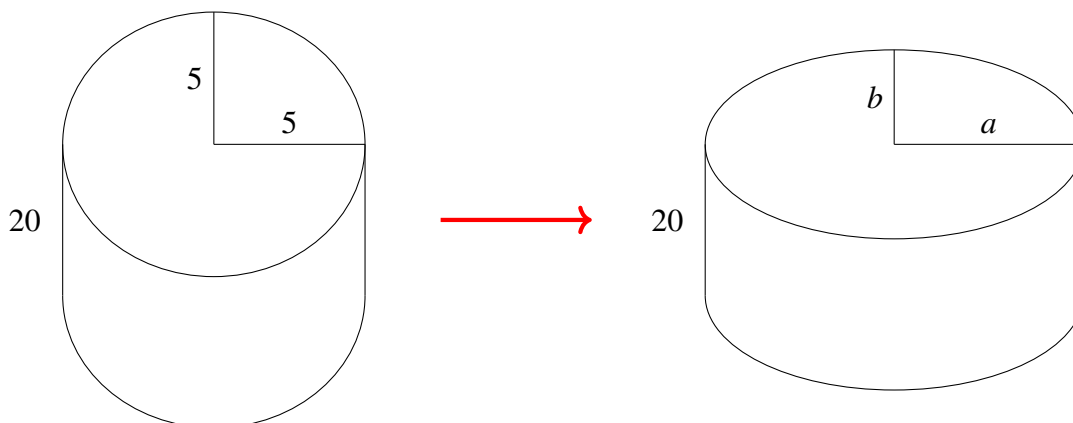

After t seconds of smooching the bottle, $a = 5 + t$ cm. The perimeter of the cross section is unchanged as the bottle deforms. The perimeter of an ellipse is actually quite difficult to calculate, but we will use an approximation derived by Ramanujan and assume that the perimeter p of our ellipse is

$$p \approx \pi \left[3(a+b) - \sqrt{(a+3b)(3a+b)} \right].$$

The area of an ellipse is πab .

- (a) Give an equation that relates a and b (and no other variables).
- (b) Give an expression for the volume of the bottle as it is being smooshed, in terms of a and b (and no other variables).
- (c) Suppose the bottle was full when its cross section was a circle. How fast is the water spilling out when a is twice as big as b ?

Q[24]:

[hint](#) [answer](#) [solution](#)

The quantities A , B , C , and D all depend on time, and are related by the formula

$$AB = \log(C^2 + D^2 + 1).$$

At time $t = 10$, the following values are known:

- $A = 0$
- $\frac{dA}{dt} = 2$ units per second

What is B when $t = 10$?

L'HÔPITAL'S RULE AND INDETERMINATE FORMS

Exercises

Jump to [HINTS](#), [ANSWERS](#), [SOLUTIONS](#) or [TABLE OF CONTENTS](#).

►► Stage 1

In Questions 1 to 20, you are asked to give pairs of functions that combine to make indeterminate forms. Remember that an indeterminate form is indeterminate precisely because its limit can take on a number of values.

Q[1]:

[hint](#) [answer](#) [solution](#)

Give two functions $f(x)$ and $g(x)$ with the following properties:

(i) $\lim_{x \rightarrow \infty} f(x) = \infty$

(ii) $\lim_{x \rightarrow \infty} g(x) = \infty$

(iii) $\lim_{x \rightarrow \infty} \frac{f(x)}{g(x)} = 2.5$

Q[2]:

[hint](#) [answer](#) [solution](#)

Give two functions $f(x)$ and $g(x)$ with the following properties:

(i) $\lim_{x \rightarrow \infty} f(x) = \infty$

(ii) $\lim_{x \rightarrow \infty} g(x) = \infty$

(iii) $\lim_{x \rightarrow \infty} \frac{f(x)}{g(x)} = 0$

►► Stage 2

Q[3](*):

[hint](#) [answer](#) [solution](#)

Evaluate $\lim_{x \rightarrow 1} \frac{x^3 - e^{x-1}}{\sin(\pi x)}$.

Q[4](*):

[hint](#) [answer](#) [solution](#)

Evaluate $\lim_{x \rightarrow 0^+} \frac{\log x}{x}$. (Remember: in these notes, log means logarithm base e .)

Q[5](*):

[hint](#) [answer](#) [solution](#)

Evaluate $\lim_{x \rightarrow \infty} (\log x)^2 e^{-x}$.

Q[6](*):

[hint](#) [answer](#) [solution](#)

Evaluate $\lim_{x \rightarrow \infty} x^2 e^{-x}$.

Q[7](*):

[hint](#) [answer](#) [solution](#)

Evaluate $\lim_{x \rightarrow 0} \frac{x - x \cos x}{x - \sin x}$.

Q[8]:

[hint](#) [answer](#) [solution](#)

Evaluate $\lim_{x \rightarrow 0} \frac{\sqrt{x^6 + 4x^4}}{x^2 \cos x}$.

Q[9](*):

[hint](#) [answer](#) [solution](#)

Evaluate $\lim_{x \rightarrow \infty} \frac{(\log x)^2}{x}$.

Q[10](*):

[answer](#) [solution](#)

Evaluate $\lim_{x \rightarrow 0} \frac{1 - \cos x}{\sin^2 x}$.

Q[11]:

[hint](#) [answer](#) [solution](#)

Evaluate $\lim_{x \rightarrow 0} \frac{x}{\sec x}$.

Q[12]:

[hint](#) [answer](#) [solution](#)

Evaluate $\lim_{x \rightarrow 0} \frac{\csc x \cdot \tan x \cdot (x^2 + 5)}{e^x}$.

Q[13](*):

[hint](#) [answer](#) [solution](#)

Evaluate $\lim_{x \rightarrow 0} \frac{\sin(x^3 + 3x^2)}{\sin^2 x}$.

Q[14](*):

[answer](#) [solution](#)

Evaluate $\lim_{x \rightarrow 1} \frac{\log(x^3)}{x^2 - 1}$.

Q[15](*):

[hint](#) [answer](#) [solution](#)

Evaluate $\lim_{x \rightarrow 0} \frac{e^{-1/x^2}}{x^4}$.

Q[16](*):

[answer](#) [solution](#)

Evaluate $\lim_{x \rightarrow 0} \frac{xe^x}{\tan(3x)}$.

Q[17](*):

[hint](#) [answer](#) [solution](#)

Find c so that $\lim_{x \rightarrow 0} \frac{1 + cx - \cos x}{e^{x^2} - 1}$ exists.

►► Stage 3Q[18](*): [hint](#) [answer](#) [solution](#)Evaluate $\lim_{x \rightarrow 0} \frac{e^{k \sin(x^2)} - (1 + 2x^2)}{x^4}$, where k is a constant.Q[19]: [hint](#) [answer](#) [solution](#)

Suppose an algorithm, given an input with n variables, will terminate in at most $S(n) = 5n^4 - 13n^3 - 4n + \log(n)$ steps. A researcher writes that the algorithm will terminate in *roughly* at most $A(n) = 5n^4$ steps. Show that the percentage error involved in using $A(n)$ instead of $S(n)$ tends to zero as n gets very large. What happens to the absolute error?

Remark: this is a very common kind of approximation. When people deal with functions that give very large numbers, often they don't care about the *exact* large number—they only want a ballpark. So, a complicated function might be replaced by an easier function that doesn't give a large relative error.

*The two standard indeterminate forms we've seen are $\frac{0}{0}$ and $\frac{\infty}{\infty}$, but these are not the **only** indeterminate forms. In Questions 20 to 24, you will see indeterminate forms that, broadly speaking, involve a function raised to a function. You saw something similar when we talked about logarithmic differentiation (section 4.4); similar algebraic manipulation will come in handy.*

Q[20]: [hint](#) [answer](#) [solution](#)Give two functions $f(x)$ and $g(x)$ with the following properties:

(i) $\lim_{x \rightarrow \infty} f(x) = 1$

(ii) $\lim_{x \rightarrow \infty} g(x) = \infty$

(iii) $\lim_{x \rightarrow \infty} [f(x)]^{g(x)} = 5$

Q[21]: [hint](#) [answer](#) [solution](#)Evaluate $\lim_{x \rightarrow 0} \sqrt{x^2 \sin^2 x}$.Q[22]: [hint](#) [answer](#) [solution](#)Evaluate $\lim_{x \rightarrow 0} \sqrt{x^2 \cos x}$.Q[23]: [hint](#) [answer](#) [solution](#)Evaluate $\lim_{x \rightarrow 0^+} e^{x \log x}$.Q[24]: [hint](#) [answer](#) [solution](#)Evaluate $\lim_{x \rightarrow 0} [-\log(x^2)]^x$.

SKETCHING GRAPHS

7.1▴ Domain, intercepts and asymptotes

Exercises

Jump to [HINTS](#), [ANSWERS](#), [SOLUTIONS](#) or [TABLE OF CONTENTS](#).

►► Stage 1

Q[1]:

[hint](#) [answer](#) [solution](#)

Suppose $f(x)$ is a function given by

$$f(x) = \frac{g(x)}{x^2 - 9}$$

where $g(x)$ is also a function. True or false: $f(x)$ has a vertical asymptote at $x = -3$.

►► Stage 2

Q[2]:

[hint](#) [answer](#) [solution](#)

Match the functions $f(x)$, $g(x)$, $h(x)$, and $k(x)$ to the curves $y = A(x)$ through $y = D(x)$.

$f(x) = \sqrt{x^2 + 1}$

$g(x) = \sqrt{x^2 - 1}$

$h(x) = \sqrt{x^2 + 4}$

$k(x) = \sqrt{x^2 - 4}$

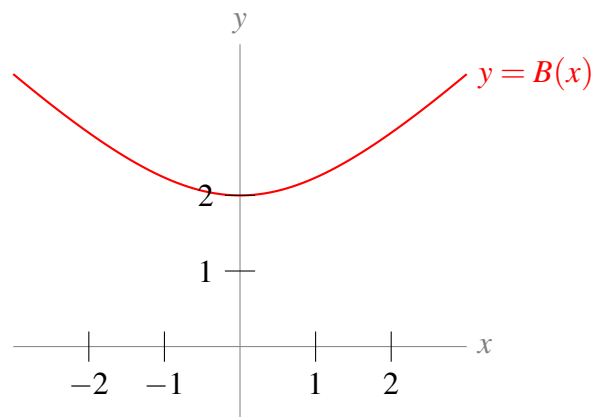
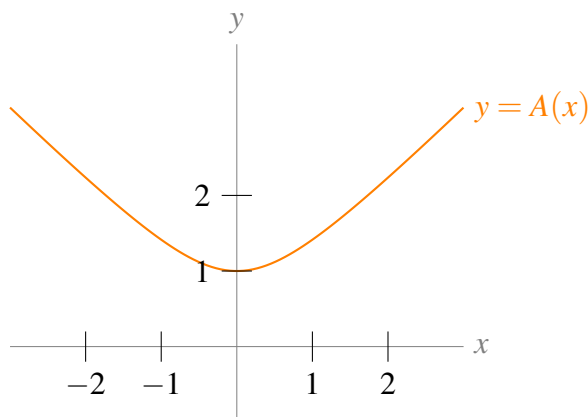

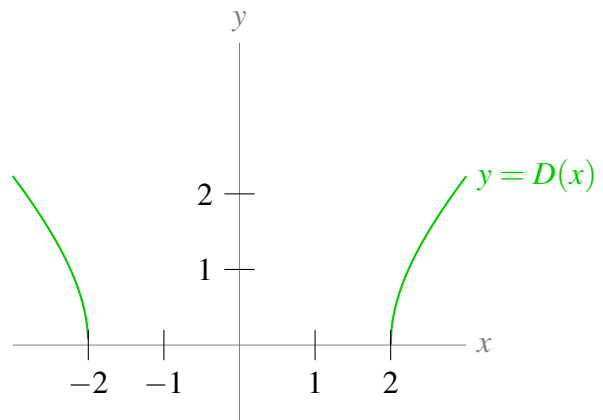
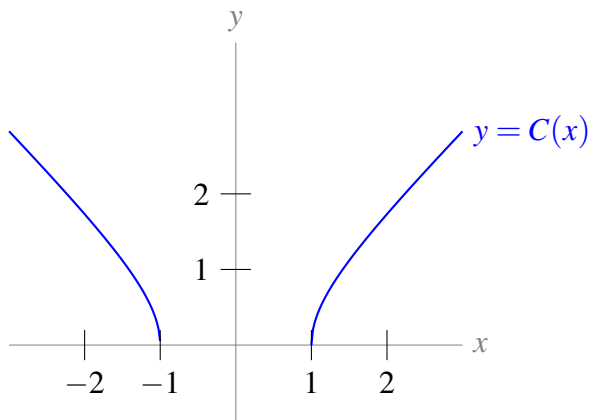

Q[3]:

[hint](#) [answer](#) [solution](#)

Below is the graph of

$$y = f(x) = \sqrt{\log^2(x+p)}$$

- (a) What is p ?
- (b) What is b (marked on the graph)?
- (c) What is the x -intercept of $f(x)$?

Remember $\log(x+p)$ is the natural logarithm of $x+p$, $\log_e(x+p)$.

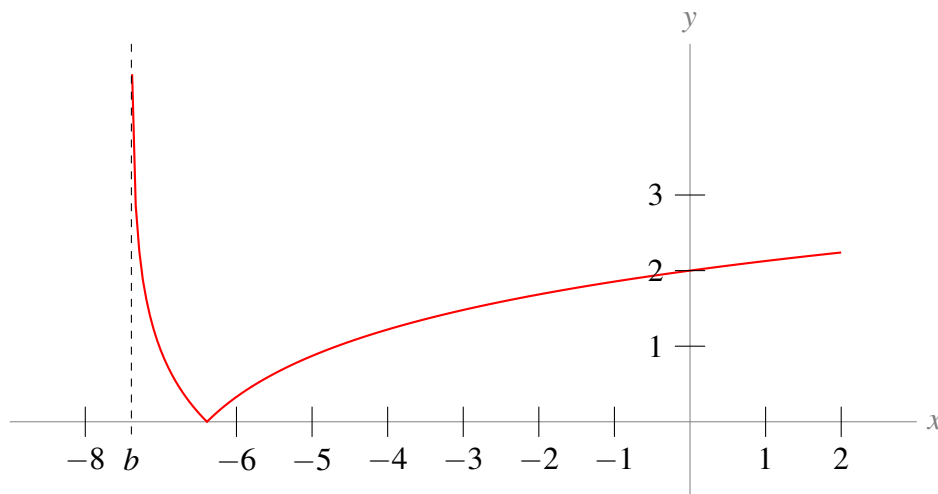

Q[4]:

[hint](#) [answer](#) [solution](#)

Find all asymptotes of $f(x) = \frac{x(2x+1)(x-7)}{3x^3-81}$.

Q[5]:

[hint](#) [answer](#) [solution](#)

Find all asymptotes of $f(x) = 10^{3x-7}$.

7.2▲ First derivative - increasing or decreasing

Exercises

Jump to [HINTS](#), [ANSWERS](#), [SOLUTIONS](#) or [TABLE OF CONTENTS](#).

►► Stage 1

Q[1]:

[hint](#) [answer](#) [solution](#)

Match each function graphed below to its *derivative* from the list. (For example, which function on the list corresponds to $A'(x)$?)

The y-axes have been scaled to make the curve's behaviour clear, so the vertical scales differ from graph to graph.

$$l(x) = (x-2)^4 \quad m(x) = (x-2)^4(x+2) \quad n(x) = (x-2)^2(x+2)^2$$

$$o(x) = (x-2)(x+2)^3 \quad p(x) = (x+2)^4$$

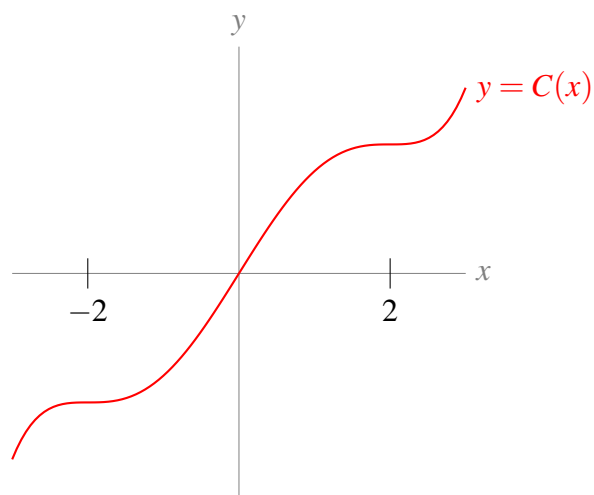
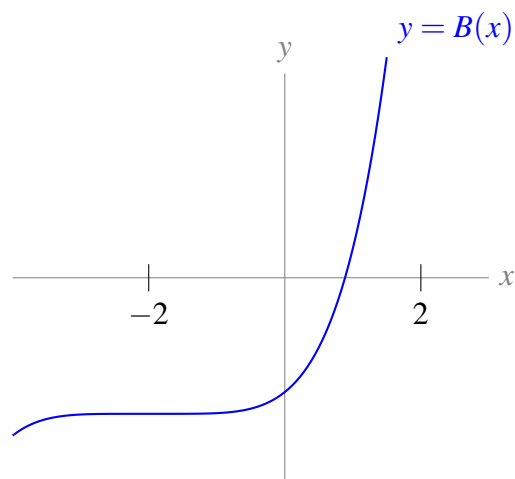
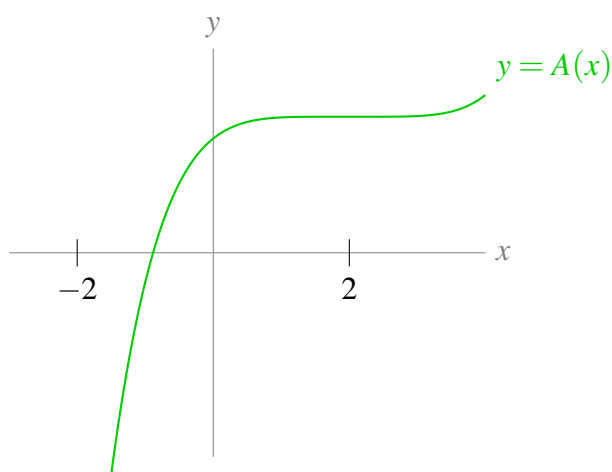

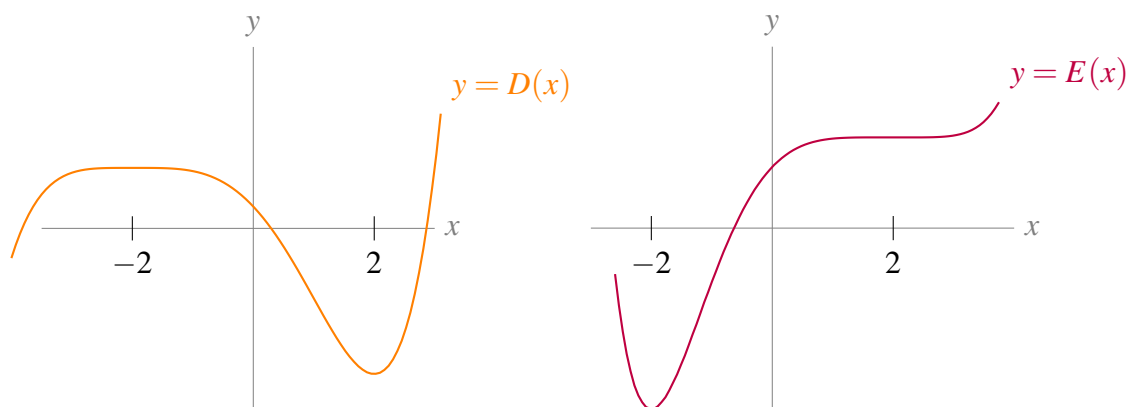

►► Stage 2

Q[2](*):

Find the largest open interval on which $f(x) = \frac{e^x}{x+3}$ is increasing.

[hint](#) [answer](#) [solution](#)

Q[3](*):

Find the largest open interval on which $f(x) = \frac{\sqrt{x-1}}{2x+4}$ is increasing.

[hint](#) [answer](#) [solution](#)

Q[4](*):

Find the largest open interval on which $f(x) = 2\arctan(x) - \log(1+x^2)$ is increasing.

[hint](#) [answer](#) [solution](#)

7.3▲ Second derivative - concavity

Exercises

Jump to [HINTS](#), [ANSWERS](#), [SOLUTIONS](#) or [TABLE OF CONTENTS](#).

►► Stage 1

Q[1]:

On the graph below, mark the intervals where $f''(x) > 0$ (i.e. $f(x)$ is concave up) and where $f''(x) < 0$ (i.e. $f(x)$ is concave down).

[hint](#) [answer](#) [solution](#)

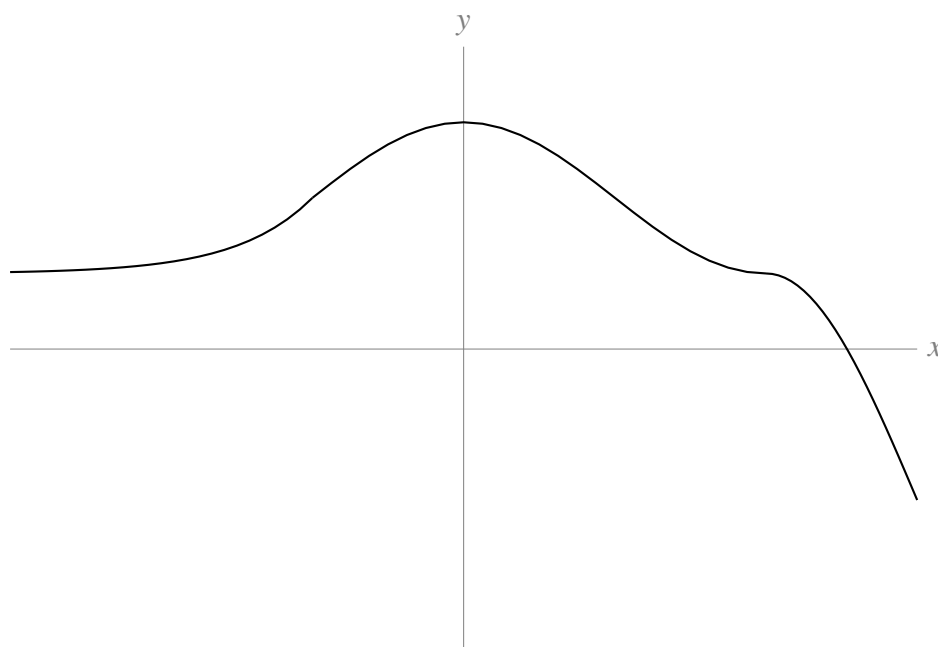

Q[2]:

[hint](#) [answer](#) [solution](#)

Sketch a curve that is:

- concave up when $|x| > 5$,
- concave down when $|x| < 5$,
- increasing when $x < 0$, and
- decreasing when $x > 0$.

Q[3]:

[hint](#) [answer](#) [solution](#)Suppose $f(x)$ is a function whose second derivative exists and is continuous for all real numbers.True or false: if $f''(3) = 0$, then $x = 3$ is an inflection point of $f(x)$.**►► Stage 2**

Q[4](*):

[answer](#) [solution](#)Find all inflection points for the graph of $f(x) = 3x^5 - 5x^4 + 13x$.**7.4▲ (optional) Symmetries****Exercises**Jump to [HINTS](#), [ANSWERS](#), [SOLUTIONS](#) or [TABLE OF CONTENTS](#).**►► Stage 1**

Q[1]:

[hint](#) [answer](#) [solution](#)

What symmetries (even, odd, periodic) does the function graphed below have?

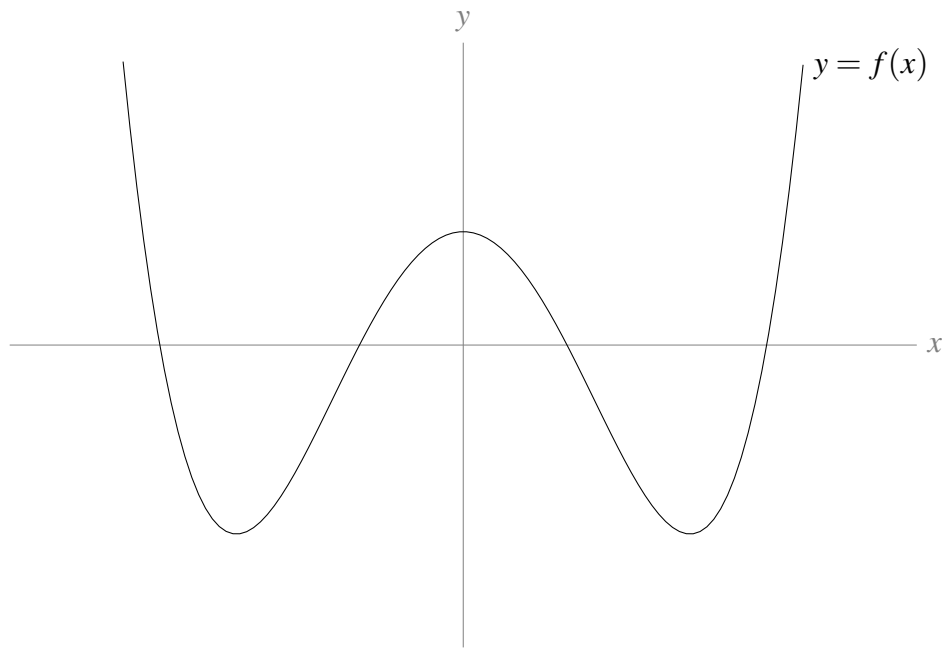

Q[2]:

[hint](#) [answer](#) [solution](#)

What symmetries (even, odd, periodic) does the function graphed below have?

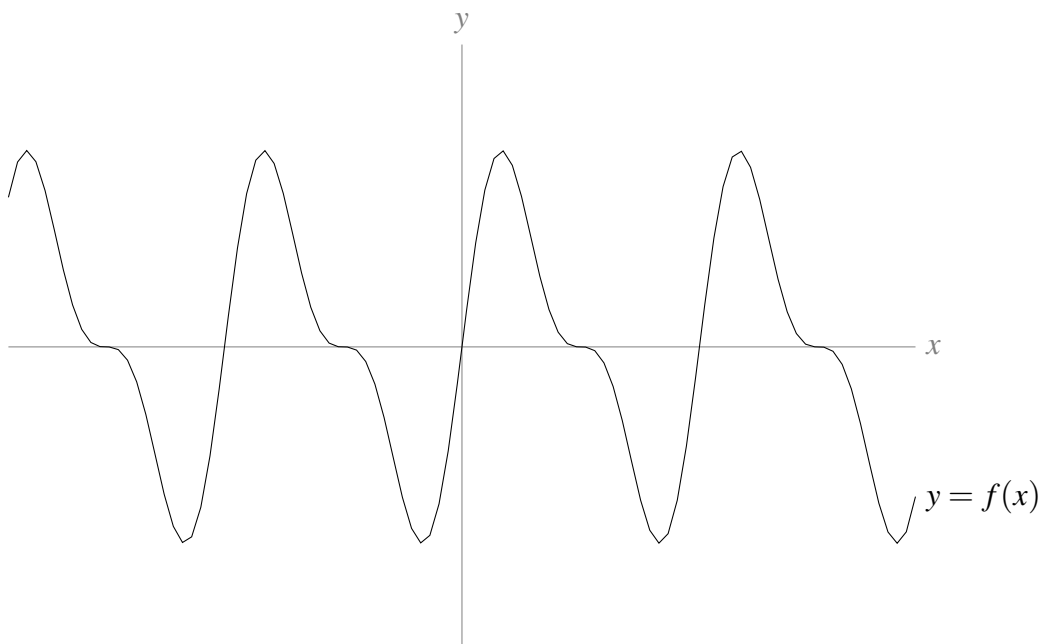

Q[3]:

[hint](#) [answer](#) [solution](#)

Suppose $f(x)$ is an even function defined for all real numbers. Below is the curve $y = f(x)$ when $x > 0$. Complete the sketch of the curve.

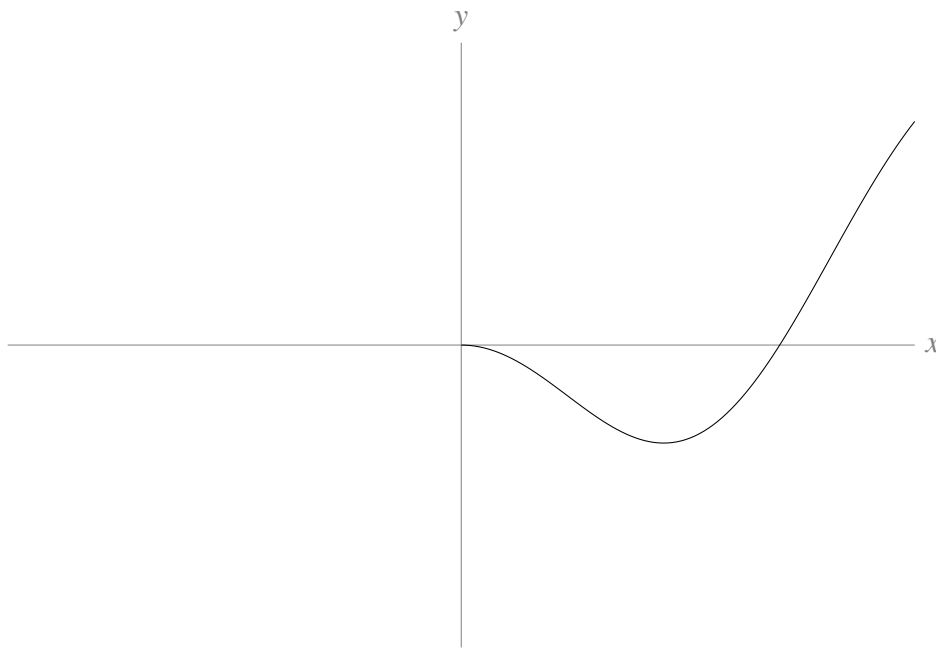

Q[4]:

[hint](#) [answer](#) [solution](#)

Suppose $f(x)$ is an odd function defined for all real numbers. Below is the curve $y = f(x)$ when $x > 0$. Complete the sketch of the curve.

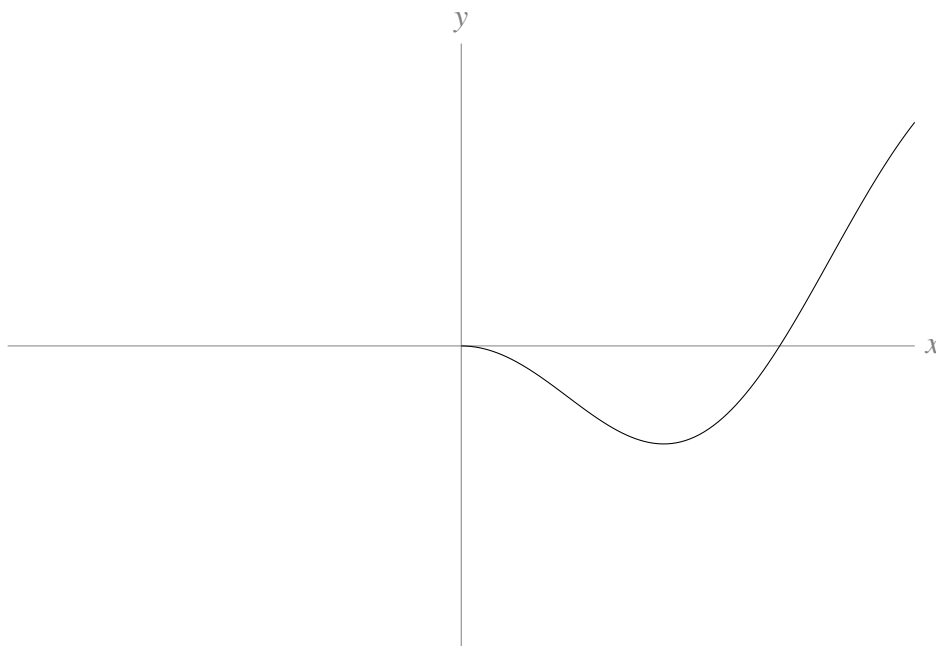

►► Stage 2

Q[5]:

[hint](#) [answer](#) [solution](#)

$$f(x) = \frac{x^4 - x^6}{e^{x^2}}$$

Show that $f(x)$ is even.

Q[6]:

[hint](#) [answer](#) [solution](#)

$$f(x) = \sin(x) + \cos\left(\frac{x}{2}\right)$$

Show that $f(x)$ is periodic.

In Questions 7 through 10, find the symmetries of a function from its equation.

Q[7]:

[hint](#) [answer](#) [solution](#)

$$f(x) = x^4 + 5x^2 + \cos(x^3)$$

What symmetries (even, odd, periodic) does $f(x)$ have?

Q[8]:

[hint](#) [answer](#) [solution](#)

$$f(x) = x^5 + 5x^4$$

What symmetries (even, odd, periodic) does $f(x)$ have?

Q[9]:

[hint](#) [answer](#) [solution](#)

$$f(x) = \tan(\pi x)$$

What is the period of $f(x)$?

►► Stage 3

Q[10]:

[hint](#) [answer](#) [solution](#)

$$f(x) = \tan(3x) + \sin(4x)$$

What is the period of $f(x)$?

7.5▲ A checklist for sketching

No exercises for Section 7.5

Jump to [TABLE OF CONTENTS](#).

7.6▲ Sketching examples

Exercises

Jump to [HINTS](#), [ANSWERS](#), [SOLUTIONS](#) or [TABLE OF CONTENTS](#).

►► Stage 2

Q[1](*):

[hint](#) [answer](#) [solution](#)

Let $f(x) = x\sqrt{3-x}$.

- Find the domain of $f(x)$.
 - Determine the x -coordinates of the local maxima and minima (if any) and intervals where $f(x)$ is increasing or decreasing.
-

- (c) Determine intervals where $f(x)$ is concave upwards or downwards, and the x coordinates of inflection points (if any). You may use, without verifying it, the formula

$$f''(x) = \frac{(3x - 12)}{4(3 - x)^{3/2}}.$$

- (d) There is a point at which the tangent line to the curve $y = f(x)$ is vertical. Find this point.
 (e) Sketch the graph $y = f(x)$, showing the features given in items (a) to (d) above and giving the (x, y) coordinates for all points occurring above.

In Questions 2 through 4, you will sketch the graphs of rational functions.

Q[2](*):

[hint](#) [answer](#) [solution](#)

Sketch the graph of

$$f(x) = \frac{x^3 - 2}{x^4}.$$

Indicate the critical points, local and absolute maxima and minima, vertical and horizontal asymptotes, inflection points and regions where the curve is concave upward or downward.

Q[3](*):

[hint](#) [answer](#) [solution](#)

The first and second derivatives of the function $f(x) = \frac{x^4}{1 + x^3}$ are:

$$f'(x) = \frac{4x^3 + x^6}{(1 + x^3)^2} \quad \text{and} \quad f''(x) = \frac{12x^2 - 6x^5}{(1 + x^3)^3}$$

Graph $f(x)$. Include local and absolute maxima and minima, regions where $f(x)$ is increasing or decreasing, regions where the curve is concave upward or downward, and any asymptotes.

Q[4](*):

[hint](#) [answer](#) [solution](#)

The first and second derivatives of the function $f(x) = \frac{x^3}{1 - x^2}$ are:

$$f'(x) = \frac{3x^2 - x^4}{(1 - x^2)^2} \quad \text{and} \quad f''(x) = \frac{6x + 2x^3}{(1 - x^2)^3}$$

Graph $f(x)$. Include local and absolute maxima and minima, regions where the curve is concave upward or downward, and any asymptotes.

Q[5](*):

[hint](#) [answer](#) [solution](#)

The function $f(x)$ is defined by

$$f(x) = \begin{cases} e^x & x < 0 \\ \frac{x^2 + 3}{3(x + 1)} & x \geq 0 \end{cases}$$

- (a) Explain why $f(x)$ is continuous everywhere.
 (b) Determine all of the following if they are present:
 i. x -coordinates of local maxima and minima, intervals where $f(x)$ is increasing or decreasing;

- ii. intervals where $f(x)$ is concave upwards or downwards;
- iii. equations of any horizontal or vertical asymptotes.

(c) Sketch the graph of $y = f(x)$, giving the (x, y) coordinates for all points of interest above.

In Questions 6 and 7, you will sketch the graphs of functions with an exponential component. In the next section, you will learn how to find their horizontal asymptotes, but for now these are given to you.

Q[6](*):

[hint](#) [answer](#) [solution](#)

The function $f(x)$ and its derivative are given below:

$$f(x) = (1 + 2x)e^{-x^2} \quad \text{and} \quad f'(x) = 2(1 - x - 2x^2)e^{-x^2}$$

Sketch the graph of $f(x)$. Indicate the critical points, local and/or absolute maxima and minima, and asymptotes. Without actually calculating the inflection points, indicate on the graph their approximate location.

Note: $\lim_{x \rightarrow \pm\infty} f(x) = 0$.

Q[7](*):

[hint](#) [answer](#) [solution](#)

Consider the function $f(x) = xe^{-x^2/2}$.

Note: $\lim_{x \rightarrow \pm\infty} f(x) = 0$.

- (a) Find all inflection points and intervals of increase, decrease, convexity up, and convexity down. You may use without proof the formula $f''(x) = (x^3 - 3x)e^{-x^2/2}$.
- (b) Find local and global minima and maxima.
- (c) Use all the above to draw a graph for f . Indicate all special points on the graph.

In Questions 8 and 9, you will sketch the graphs of functions that have a trigonometric component.

Q[8]:

[hint](#) [answer](#) [solution](#)

Use the techniques from this section to sketch the graph of $f(x) = x + 2\sin x$.

Q[9](*):

[hint](#) [answer](#) [solution](#)

$$f(x) = 4\sin x - 2\cos 2x$$

Graph the equation $y = f(x)$, including all important features. (In particular, find all local maxima and minima and all inflection points.) Additionally, find the maximum and minimum values of $f(x)$ on the interval $[0, \pi]$.

Q[10]:

[hint](#) [answer](#) [solution](#)

Sketch the curve $y = \sqrt[3]{\frac{x+1}{x^2}}$.

You may use the facts $y'(x) = \frac{-(x+2)}{3x^{5/3}(x+1)^{2/3}}$ and $y''(x) = \frac{4x^2 + 16x + 10}{9x^{8/3}(x+1)^{5/3}}$.

►► Stage 3

Q[11](*):

[hint](#) [answer](#) [solution](#)

A function $f(x)$ defined on the whole real number line satisfies the following conditions

$$f(0) = 0 \quad f(2) = 2 \quad \lim_{x \rightarrow +\infty} f(x) = 0 \quad f'(x) = K(2x - x^2)e^{-x}$$

for some positive constant K . (Read carefully: you are given the *derivative* of $f(x)$, not $f(x)$ itself.)

- Determine the intervals on which f is increasing and decreasing and the location of any local maximum and minimum values of f .
- Determine the intervals on which f is concave up or down and the x -coordinates of any inflection points of f .
- Determine $\lim_{x \rightarrow -\infty} f(x)$.
- Sketch the graph of $y = f(x)$, showing any asymptotes and the information determined in parts (a) and (b).

Q[12](*):

[hint](#) [answer](#) [solution](#)

Let $f(x) = e^{-x}$, $x \geq 0$.

- Sketch the graph of the equation $y = f(x)$. Indicate any local extrema and inflection points.
- Sketch the graph of the inverse function $y = g(x) = f^{-1}(x)$.
- Find the domain and range of the inverse function $g(x) = f^{-1}(x)$.
- Evaluate $g'(\frac{1}{2})$.

Q[13](*):

[answer](#) [solution](#)

- Sketch the graph of $y = f(x) = x^5 - x$, indicating asymptotes, local maxima and minima, inflection points, and where the graph is concave up/concave down.
- Consider the function $f(x) = x^5 - x + k$, where k is a constant, $-\infty < k < \infty$. How many roots does the function have? (Your answer might depend on the value of k .)

Q[14](*):

[hint](#) [answer](#) [solution](#)

The hyperbolic trigonometric functions $\sinh(x)$ and $\cosh(x)$ are defined by

$$\sinh(x) = \frac{e^x - e^{-x}}{2} \quad \cosh(x) = \frac{e^x + e^{-x}}{2}$$

They have many properties that are similar to corresponding properties of $\sin(x)$ and $\cos(x)$. In particular, it is easy to see that

$$\frac{d}{dx} \sinh(x) = \cosh(x) \quad \frac{d}{dx} \cosh(x) = \sinh(x) \quad \cosh^2(x) - \sinh^2(x) = 1$$

You may use these properties in your solution to this question.

- Sketch the graphs of $\sinh(x)$ and $\cosh(x)$.
- Define inverse hyperbolic trigonometric functions $\sinh^{-1}(x)$ and $\cosh^{-1}(x)$, carefully specifying their domains of definition. Sketch the graphs of $\sinh^{-1}(x)$ and $\cosh^{-1}(x)$.
- Find $\frac{d}{dx} \{\cosh^{-1}(x)\}$.

OPTIMIZATION

8.1▲ Local and global maxima and minima**Exercises**

Jump to [HINTS](#), [ANSWERS](#), [SOLUTIONS](#) or [TABLE OF CONTENTS](#).

►► Stage 1

Q[1]:

[hint](#) [answer](#) [solution](#)

Identify every critical point and every singular point of $f(x)$ shown on the graph below. Which correspond to local extrema?

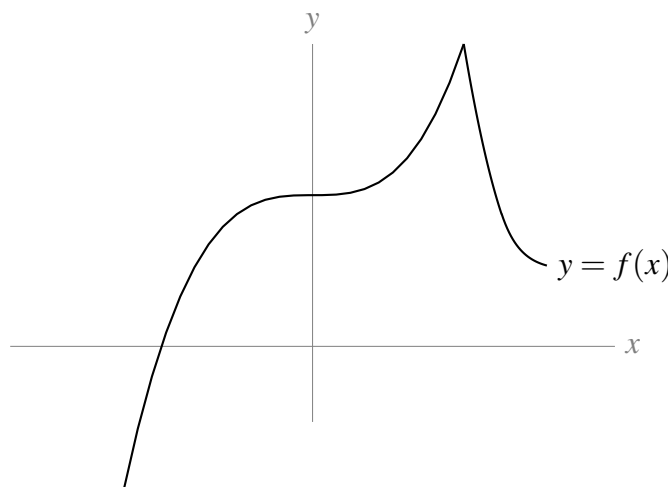

Q[2]:

[hint](#) [answer](#) [solution](#)

Identify every critical point and every singular point of $f(x)$ on the graph below. Which correspond to local extrema? Which correspond to global extrema over the interval shown?

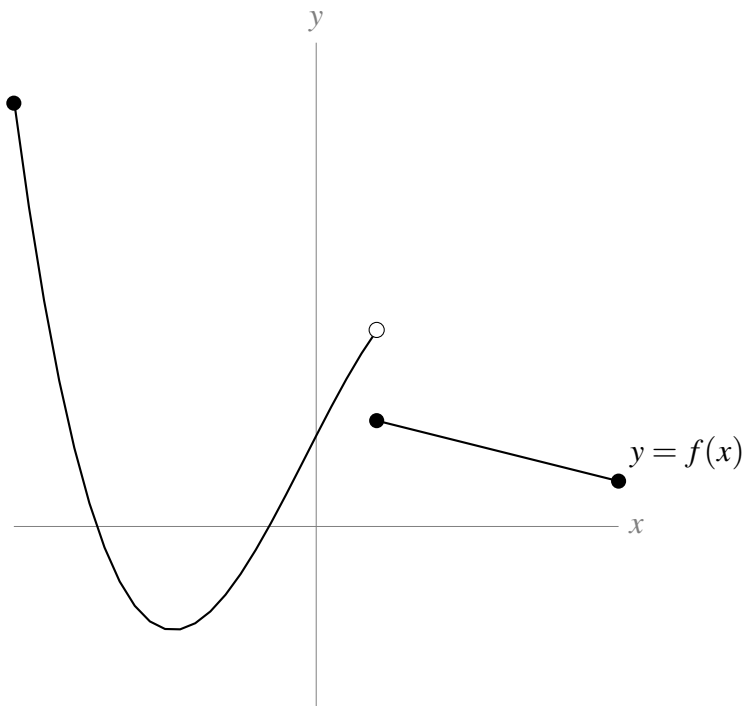

Q[3]:

[hint](#) [answer](#) [solution](#)

Draw a graph $y = f(x)$ where $f(2)$ is a local maximum, but it is not a global maximum.

►► Stage 2

Q[4]:

[hint](#) [answer](#) [solution](#)

Suppose $f(x) = \frac{x-1}{x^2+3}$.

- Find all critical points.
- Find all singular points.
- What are the possible points where local extrema of $f(x)$ may exist?

►► Stage 3

Q[5]:

[hint](#) [answer](#) [solution](#)

Below are a number of curves, all of which have a singular point at $x = 2$. For each, label whether $x = 2$ is a local maximum, a local minimum, or neither.

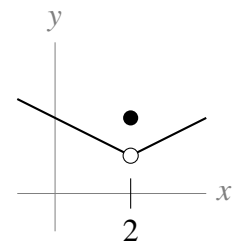
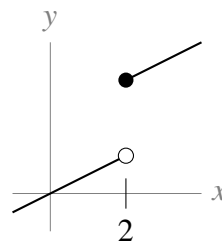
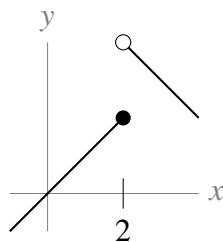
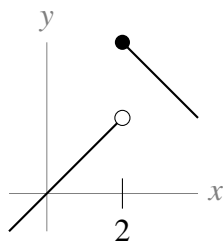

Q[6]:

[hint](#) [answer](#) [solution](#)

Draw a graph $y = f(x)$ where $f(2)$ is a local maximum, but $x = 2$ is not a critical point and is not an endpoint.

Q[7]:

[hint](#) [answer](#) [solution](#)

$$f(x) = \sqrt{|(x-5)(x+7)|}$$

Find all critical points and all singular points of $f(x)$. You do not have to specify whether a point is critical or singular.

Q[8]:

[hint](#) [answer](#) [solution](#)

Suppose $f(x)$ is the constant function $f(x) = 4$. What are the critical points and singular points of $f(x)$? What are its local and global maxima and minima?

8.2▲ Finding global maxima and minima

Exercises

Jump to [HINTS](#), [ANSWERS](#), [SOLUTIONS](#) or [TABLE OF CONTENTS](#).

►► Stage 1

Q[1]:

[hint](#) [answer](#) [solution](#)

Sketch a function $f(x)$ such that:

- $f(x)$ is defined over all real numbers
- $f(x)$ has a global max but no global min.

Q[2]:

[hint](#) [answer](#) [solution](#)

Sketch a function $f(x)$ such that:

- $f(x)$ is defined over all real numbers
- $f(x)$ is always positive
- $f(x)$ has no global max and no global min.

Q[3]:

[hint](#) [answer](#) [solution](#)

Sketch a function $f(x)$ such that:

- $f(x)$ is defined over all real numbers
- $f(x)$ has a global minimum at $x = 5$
- $f(x)$ has a global minimum at $x = -5$, too.

►► Stage 2

Q[4]:

[hint](#) [answer](#) [solution](#)

$f(x) = x^2 + 6x - 10$. Find all global extrema on the interval $[-5, 5]$

Q[5]:

[hint](#) [answer](#) [solution](#)

$f(x) = \frac{2}{3}x^3 - 2x^2 - 30x + 7$. Find all global extrema on the interval $[-4, 0]$.

8.3▲ Max/min examples

Exercises

Jump to [HINTS](#), [ANSWERS](#), [SOLUTIONS](#) or [TABLE OF CONTENTS](#).

►► Stage 2

For Questions 1 through 3, the quantity to optimize is already given to you as a function of a single variable.

Q[1](*): [hint](#) [answer](#) [solution](#)

Find the global maximum and the global minimum for $f(x) = x^5 - 5x + 2$ on the interval $[-2, 0]$.

Q[2](*): [hint](#) [answer](#) [solution](#)

Find the global maximum and the global minimum for $f(x) = x^5 - 5x - 10$ on the interval $[0, 2]$.

Q[3](*): [answer](#) [solution](#)

Find the global maximum and the global minimum for $f(x) = 2x^3 - 6x^2 - 2$ on the interval $[1, 4]$.

For Questions 4 and 5, you can decide whether a critical point is a local extremum by considering the derivative of the function.

Q[4](*): [hint](#) [answer](#) [solution](#)

Consider the function $h(x) = x^3 - 12x + 4$. What are the coordinates of the local maximum of $h(x)$?
What are the coordinates of the local minimum of $h(x)$?

Q[5](*): [hint](#) [answer](#) [solution](#)

Consider the function $h(x) = 2x^3 - 24x + 1$. What are the coordinates of the local maximum of $h(x)$? What are the coordinates of the local minimum of $h(x)$?

For Questions 6 through 13, you will have to find an expression for the quantity you want to optimize as a function of a single variable.

Q[6](*): [hint](#) [answer](#) [solution](#)

You are in a dune buggy at a point P in the desert, 12 km due south of the nearest point A on a straight east-west road. You want to get to a town B on the road 18 km east of A . If your dune buggy can travel at an average speed of 15 km/hr through the desert and 30 km/hr along the road, towards what point Q on the road should you head to minimize your travel time from P to B ?

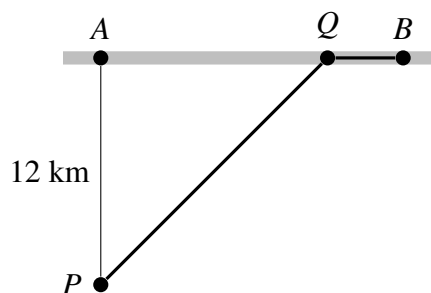

Q[7](*): [hint](#) [answer](#) [solution](#)

A closed three dimensional box is to be constructed in such a way that its volume is 4500 cm^3 . It is also specified that the length of the base is 3 times the width of the base. Find the dimensions of the box that satisfies these conditions and has the minimum possible surface area. Justify your answer.

Q[8](*):

[hint](#) [answer](#) [solution](#)

A closed rectangular container with a square base is to be made from two different materials. The material for the base costs \$5 per square metre, while the material for the other five sides costs \$1 per square metre. Find the dimensions of the container which has the largest possible volume if the total cost of materials is \$72.

Q[9](*):

[hint](#) [answer](#) [solution](#)

Find a point X on the positive x -axis and a point Y on the positive y -axis such that (taking $O = (0,0)$)

- (i) The triangle XOY contains the first quadrant portion of the unit circle $x^2 + y^2 = 1$ and
- (ii) the area of the triangle XOY is as small as possible.

A complete and careful mathematical justification of property (i) is required.

Q[10](*):

[hint](#) [answer](#) [solution](#)

A rectangle is inscribed in a semicircle of radius R so that one side of the rectangle lies along a diameter of the semicircle. Find the largest possible perimeter of such a rectangle, if it exists, or explain why it does not. Do the same for the smallest possible perimeter.

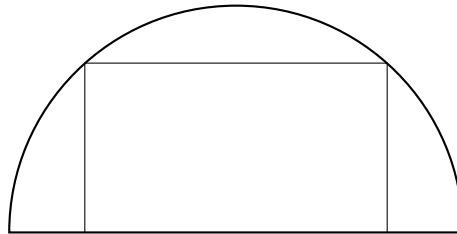

Q[11](*):

[hint](#) [answer](#) [solution](#)

Find the maximal possible volume of a cylinder with surface area A .¹

Q[12](*):

[hint](#) [answer](#) [solution](#)

What is the largest possible area of a window, with perimeter P , in the shape of a rectangle with a semicircle on top (so the diameter of the semicircle equals the width of the rectangle)?

Q[13](*):

[answer](#) [solution](#)

Consider an open-top rectangular baking pan with base dimensions x centimetres by y centimetres and height z centimetres that is made from A square centimetres of tin plate. Suppose $y = px$ for some fixed constant p .

- (a) Find the dimensions of the baking pan with the maximum capacity (i.e., maximum volume). Prove that your answer yields the baking pan with maximum capacity. Your answer will depend on the value of p .
- (b) Find the value of the constant p that yields the baking pan with maximum capacity and give the dimensions of the resulting baking pan. Prove that your answer yields the baking pan with maximum capacity.

¹ Food is often packaged in cylinders, and companies wouldn't want to waste the metal they are made out of. So, you might expect the dimensions you find in this problem to describe a tin of, say, cat food. [Read here](#) about why this *isn't* the case.

►► Stage 3

Q[14](*):

[hint](#) [answer](#) [solution](#)Let $f(x) = x^x$ for $x > 0$.

- (a) Find $f'(x)$.
- (b) At what value of x does the curve $y = f(x)$ have a horizontal tangent line?
- (c) Does the function f have a local maximum, a local minimum, or neither of these at the point x found in part (b)?

Q[15](*):

[hint](#) [answer](#) [solution](#)

A length of wire is cut into two pieces, one of which is bent to form a circle, the other to form a square. How should the wire be cut if the area enclosed by the two curves is maximized? How should the wire be cut if the area enclosed by the two curves is minimized? Justify your answers.

8.4▲ Sample optimization problems**Exercises**Jump to [HINTS](#), [ANSWERS](#), [SOLUTIONS](#) or [TABLE OF CONTENTS](#).

Q[1]:

Find the numbers. The sum of two positive number is 20. Find the numbers

- (a) if their product is a maximum,
- (b) if the sum of their squares is a minimum,
- (c) if the product of the square of one and the cube of the other is a maximum.

Q[2]:

Distance, velocity and acceleration. A tram ride departs from its starting place at $t = 0$ and travels to the end of its route and back. Its distance from the terminal at time t can be approximately described by the expression

$$S(t) = 4t^3(10 - t)$$

where t is in minutes, $0 < t < 10$, and S is distance in meters.

- (a) Find the velocity as a function of time.
- (b) When is the tram moving at the fastest rate?
- (c) At what time does it get to the furthest point away from its starting position?
- (d) Sketch the acceleration, the velocity, and the position of the tram on the same set of axes.

Q[3]:

Distance of two cars. At 9A.M., car B is 25 km west of car A . Car A then travels to the south at 30 km/h and car B travels east at 40 km/h. When are they closest to each other and what is this distance?

Q[4]:

Cannonball movement. A cannonball is shot vertically upwards from the ground with initial velocity $v_0 = 15\text{m/sec}$. The height of the ball, y (in meters), as a function of the time, t (in sec) is

given by

$$y = v_0 t - 4.9t^2$$

Determine the following:

- the time at which the cannonball reaches its highest point,
- the velocity and acceleration of the cannonball at $t = 0.5$ s, and $t = 1.5$ s, and
- the time at which the cannonball hits the ground.

Q[5]:

Dimensions of a box. A closed 3-dimensional box is to be constructed in such a way that its volume is 4500 cm^3 . It is also specified that the length of the base is 3 times the width of the base.

Determine the dimensions of the box which satisfy these conditions and have the minimum possible surface area. Justify your answer.

Q[6]:

Dimensions of a box. A box with a square base is to be made so that its diagonal has length 1; see Figure 8.1.

- What height y would make the volume maximal?
- What is the maximal volume? (*hint*: a box having side lengths ℓ , w , h has diagonal length D where $D^2 = \ell^2 + w^2 + h^2$ and volume $V = \ell wh$).

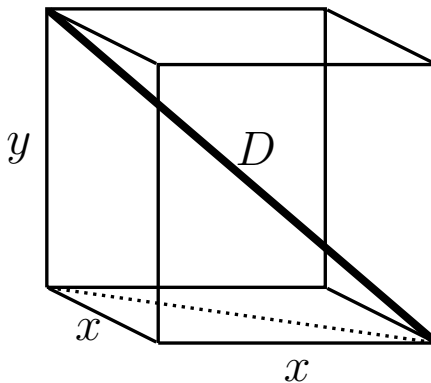

Figure 8.1: Figure for Exercise 6; box with a square base.

Q[7]:

Minimum distance. Find the minimum distance from a point on the positive x -axis $(a, 0)$ to the parabola $y^2 = 8x$.

Q[8]:

The largest garden. You are building a fence to completely enclose part of your backyard for a vegetable garden. You have already purchased material for a fence of length 100 ft.

What is the largest rectangular area that this fence can enclose?

Q[9]:

Two gardens. A fence of length 100 ft is to be used to enclose two gardens. One garden is to have a circular shape, and the other to be square.

Determine how the fence should be cut so that the sum of the areas inside both gardens is as large as possible.

Q[10]:

Dimensions of an open box. A rectangular piece of cardboard with dimension 12 cm by 24 cm is to be made into an open box (i.e., no lid) by cutting out squares from the corners and then turning up the sides.

Find the size of the squares that should be cut out if the volume of the box is to be a maximum.

Q[11]:

Alternate solution to Kepler's wine barrel. In this exercise we follow an alternate approach to the most economical wine barrel problem posed by Kepler (as in Example 8.4.2 in the text).

Through this approach, we find the proportions (height:radius) of the cylinder that minimizes the length L of the wet rod in Figure 8.2 for a fixed volume.

- Explain why minimizing L is equivalent to minimizing L^2 in Eqn. 8.4.2
- Explain how Eqn. 8.4.1 can be used to specify a constraint for this problem. (*hint*: consider the volume, V to be fixed and show that you can solve for r^2).
- Use your result in (c) to eliminate r from the formula for L^2 . Now $L^2(h)$ depends only on the height of the cylindrical wine barrel.
- Use calculus to find any local minima for $L^2(h)$. Be sure to verify that your result is a minimum.
- Find the corresponding value of r using your result in (b).
- Find the ratio h/r . You should obtain the same result as in Eqn. 8.4.3.

Q[12]:

Rectangle with largest area. Find the side lengths, x and y , of the rectangle with largest area whose diameter L is given (*hint*: eliminate one variable using the constraint. To simplify the derivative, consider that critical points of A would also be critical points of A^2 , where $A = xy$ is the area of the rectangle. If you have already learned the chain rule, you can use it in the differentiation).

Q[13]:

Shortest path. Find the shortest path that would take a milk-maid from her house at $(10, 10)$ to fetch water at the river located along the x -axis and then to the thirsty cow at $(3, 5)$.

Q[14]:

Water and ice. Why does ice float on water? Because the density of ice is lower! In fact, water is the only common liquid whose maximal density occurs above its freezing temperature. This phenomenon favours the survival of aquatic life by preventing ice from forming at the bottoms of lakes. According to the *Handbook of Chemistry and Physics*, a mass of water that occupies one liter at 0°C occupies a volume (in liters) of

$$V = -aT^3 + bT^2 - cT + 1$$

at $T^\circ\text{C}$ where $0 \leq T \leq 30$ and where the coefficients are

$$a = 6.79 \times 10^{-8}, \quad b = 8.51 \times 10^{-6}, \quad c = 6.42 \times 10^{-5}.$$

Find the temperature between 0°C and 30°C at which the density of water is the greatest. (*hint*: maximizing the density is equivalent to minimizing the volume. Why is this?).

Q[15]:

Drug doses and sensitivity. The *reaction* $R(x)$ of a patient to a drug dose of size x depends on the type of drug. For a certain drug, it was determined that a good description of the relationship is:

$$R(x) = Ax^2(B - x)$$

where A and B are positive constants. The *sensitivity* of the patient's body to the drug is defined to be $R'(x)$.

- For what value of x is the reaction a maximum, and what is that maximum reaction value?
- For what value of x is the sensitivity a maximum? What is the maximum sensitivity?

Q[16]:

Thermoregulation in a swarm of bees. In the winter, honeybees sometimes escape the hive and form a tight swarm in a tree, where, by shivering, they can produce heat and keep the swarm temperature elevated.

Heat energy is lost through the surface of the swarm at a rate proportional to the surface area (k_1S where $k_1 > 0$ is a constant). Heat energy is produced inside the swarm at a rate proportional to the mass of the swarm (which you may take to be a constant times the volume). We assume that the heat production is k_2V where $k_2 > 0$ is constant.

Swarms that are not large enough may lose more heat than they can produce, and then they die. The heat depletion rate is the loss rate minus the production rate. Assume that the swarm is spherical.

Find the size of the swarm for which the rate of depletion of heat energy is greatest.

Q[17]:

Circular cone circumscribed about a sphere. A right circular cone is circumscribed about a sphere of radius 5. Find the dimension of this cone if its volume is to be a minimum.

Note: this is a rather challenging geometric problem.

Q[18]:

Optimal reproductive strategy. Animals that can produce many healthy babies that survive to the next generation are at an evolutionary advantage over other, competing, species. However, too many young produce a heavy burden on the parents (who must feed and care for them). If this causes the parents to die, the advantage is lost. Further, competition of the young with one another for food and parental attention jeopardizes the survival of these babies.

Suppose that the evolutionary **Advantage** A to the parents of having litter size x is

$$A(x) = ax - bx^2.$$

Suppose that the **Cost** C to the parents of having litter size x is

$$C(x) = mx + e.$$

The **Net Reproductive Gain** G is defined as

$$G = A - C.$$

- (a) Explain the expressions for A, C and G .
- (b) At what litter size is the advantage, A , greatest?
- (c) At what litter size is there least cost to the parents?
- (d) At what litter size is the Net Reproductive Gain greatest?

Q[19]:

Behavioural Ecology. Social animals that live in groups can spend less time scanning for predators than solitary individuals. However, they waste time fighting with the other group members over the available food. There is some group size at which the net benefit is greatest because the animals spend the least time on these unproductive activities - and thus can spend time on feeding, mating, etc.

Assume that for a group of size x , the fraction of time spent scanning for predators is

$$S(x) = A \frac{1}{(x+1)}$$

and the fraction of time spent fighting with other animals over food is

$$F(x) = B(x+1)^2$$

where A, B are constants.

Find the size of the group for which the time wasted on scanning and fighting is smallest.

Q[20]:

Logistic growth. Consider a fish population whose density (individuals per unit area) is N , and suppose this fish population grows **logistically**, so that the rate of growth R satisfies

$$R(N) = rN(1 - N/K)$$

where r and K are positive constants.

- (a) Sketch R as a function of N or explain Figure 8.2.

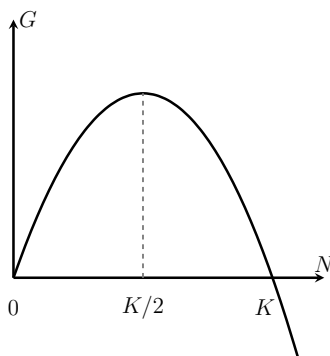

Figure 8.2: In logistic growth, the population growth rate G depends on population size N as shown here.

- (b) Use a first derivative test to justify the claim that $N = K/2$ is a local maximum for the function $G(N)$.

Q[21]:

Logistic growth with harvesting. Consider a fish population of density N growing logistically, i.e. with rate of growth $R(N) = rN(1 - N/K)$ where r and K are positive constants. The rate of harvesting (i.e. removal) of the population is

$$h(N) = qEN$$

where E , the effort of the fishermen, and q , the catchability of this type of fish, are positive constants.

At what density of fish does the growth rate exactly balance the harvesting rate? This density is called the maximal sustainable yield: MSY.

Q[22]:

Conservation of a harvested population. Conservationists insist that the density of fish should never be allowed to go below a level at which growth rate of the fish exactly balances with the harvesting rate. At this level, the harvesting is at its maximal sustainable yield. If more fish are taken, the population keeps dropping and the fish eventually go extinct.

What level of fishing effort should be used to lead to the greatest harvest at this maximal sustainable yield?

Note: you should first complete the Exercise 21.

Q[23]:

Rate of net energy gain while foraging and traveling. Animals spend energy in traveling and foraging. In some environments this energy loss is a significant portion of the energy budget. In such cases, it is customary to assume that to survive, an individual would optimize the rate of *net* energy gain, defined as

$$Q(t) = \frac{\text{Net energy gained}}{\text{total time spent}} = \frac{\text{Energy gained} - \text{Energy lost}}{\text{total time spent}} \quad (8.4.1)$$

Assume that the animal spends p energy units per unit time in all activities (including foraging and traveling). Assume that the energy gain in the patch (“patch energy function”) is given by Eqn. 8.4.4.

Find the optimal patch time, that is the time at which $Q(t)$ is maximized in this scenario.

Q[24]:

Maximizing net energy gain: Suppose that the situation requires an animal to maximize its net energy gained $E(t)$ defined as

$$E(t) = \text{energy gained while foraging} \\ - \text{energy spent while foraging and traveling.}$$

(This means that $E(t) = f(t) - r(t + \tau)$ where r is the rate of energy spent per unit time and τ is the fixed travel time).

Assume as before that the energy gained by foraging for a time t in the food patch is $f(t) = E_{max}t/(k+t)$.

- (a) Find the amount of time t spent foraging that maximizes $E(t)$.
- (b) Indicate a condition of the form $k < \boxed{?}$ that is required for existence of this critical point.

APPROXIMATING FUNCTIONS NEAR A SPECIFIED POINT – TAYLOR POLYNOMIALS

9.1▲ Zeroth approximation

Exercises

Jump to [HINTS](#), [ANSWERS](#), [SOLUTIONS](#) or [TABLE OF CONTENTS](#).

►► Stage 1

Q[1]:

[hint](#) [answer](#) [solution](#)

The graph below shows three curves. The black curve is $y = f(x)$, the red curve is $y = g(x) = 1 + 2 \sin(1 + x)$, and the blue curve is $y = h(x) = 0.7$. If you want to estimate $f(0)$, what might cause you to use $g(0)$? What might cause you to use $h(0)$?

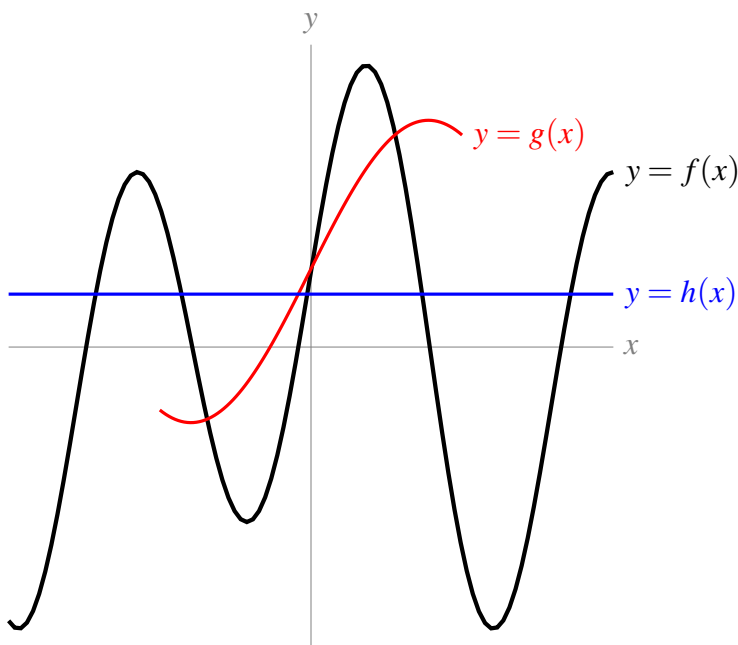

►► Stage 2

In this and following sections, we will ask you to approximate the value of several constants, such as $\log(0.93)$. A valid question to consider is why we would ask for approximations of these constants that take lots of time, and are less accurate than what you get from a calculator.

One answer to this question is historical: people were approximating logarithms before they had calculators, and these are some of the ways they did that. Pretend you're on a desert island without any of your usual devices and that you want to make a number of quick and dirty approximate evaluations.

Another reason to make these approximations is technical: how does the calculator get such a good approximation of $\log(0.93)$? The techniques you will learn later on in this chapter give very accurate formulas for approximating functions like $\log x$ and $\sin x$, which are sometimes used in calculators.

A third reason to make simple approximations of expressions that a calculator could evaluate is to provide a reality check. If you have a ballpark guess for your answer, and your calculator gives you something wildly different, you know to double-check that you typed everything in correctly.

For now, questions like [Question 2](#) through [Question 4](#) are simply for you to practice the fundamental ideas we're learning.

Q[2]:

[hint](#) [answer](#) [solution](#)

Use a constant approximation to estimate the value of $\log(x)$ when $x = 0.93$. Sketch the curve $y = f(x)$ and your constant approximation.

(Remember that we use $\log x$ to mean the natural logarithm of x , $\log_e x$.)

Q[3]:

[hint](#) [answer](#) [solution](#)

Use a constant approximation to estimate $\arcsin(0.1)$.

Q[4]:

[hint](#) [answer](#) [solution](#)

Use a constant approximation to estimate $\sqrt{3} \tan(1)$.

►► Stage 3

Q[5]:

[hint](#) [answer](#) [solution](#)

Use a constant approximation to estimate the value of 10.1^3 . Your estimation should be something you can calculate in your head.

9.2▲ Linear approximation

Exercises

Jump to [HINTS](#), [ANSWERS](#), [SOLUTIONS](#) or [TABLE OF CONTENTS](#).

►► Stage 1

Q[1]:

[hint](#) [answer](#) [solution](#)

Suppose $f(x)$ is a function, and we calculated its linear approximation near $x = 5$ to be $f(x) \approx 3x - 9$.

- (a) What is $f(5)$?
- (b) What is $f'(5)$?
- (c) What is $f(0)$?

Q[2]:

[hint](#) [answer](#) [solution](#)

The curve $y = f(x)$ is shown below. Sketch the linear approximation of $f(x)$ about $x = 2$.

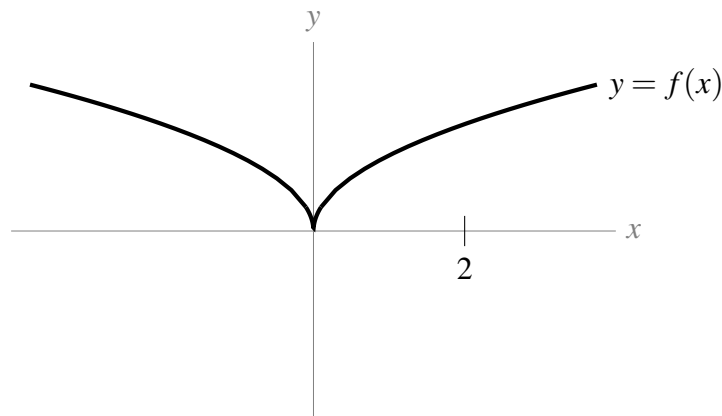

Q[3]:

[hint](#) [answer](#) [solution](#)

What is the linear approximation of the function $f(x) = 2x + 5$ about $x = a$?

►► Stage 2

Q[4]:

[hint](#) [answer](#) [solution](#)

Use a linear approximation to estimate $\log(x)$ when $x = 0.93$. Sketch the curve $y = f(x)$ and your linear approximation.

(Remember we use $\log x$ to mean the natural logarithm of x , $\log_e x$.)

Q[5]:

[hint](#) [answer](#) [solution](#)

Use a linear approximation to estimate $\sqrt{5}$.

Q[6]:

[hint](#) [answer](#) [solution](#)Use a linear approximation to estimate $\sqrt[5]{30}$ **►► Stage 3**

Q[7]:

[hint](#) [answer](#) [solution](#)Use a linear approximation to estimate 10.1^3 , then compare your estimation with the actual value.

Q[8]:

[hint](#) [answer](#) [solution](#)

Imagine $f(x)$ is some function, and you want to estimate $f(b)$. To do this, you choose a value a and take an approximation (linear or constant) of $f(x)$ about a . Give an example of a function $f(x)$, and values a and b , where the constant approximation gives a more accurate estimation of $f(b)$ than the linear approximation.

Q[9]:

[hint](#) [answer](#) [solution](#)

The function

$$L(x) = \frac{1}{4}x + \frac{4\pi - \sqrt{27}}{12}$$

is the linear approximation of $f(x) = \arctan x$ about what point $x = a$?**9.3▲ Quadratic approximation****Exercises**Jump to [HINTS](#), [ANSWERS](#), [SOLUTIONS](#) or [TABLE OF CONTENTS](#).**►► Stage 1**

Q[1]:

[hint](#) [answer](#) [solution](#)The quadratic approximation of a function $f(x)$ about $x = 3$ is

$$f(x) \approx -x^2 + 6x$$

What are the values of $f(3)$, $f'(3)$, $f''(3)$, and $f'''(3)$?

Q[2]:

[hint](#) [answer](#) [solution](#)Give a quadratic approximation of $f(x) = 2x + 5$ about $x = a$.**►► Stage 2**

Q[3]:

[hint](#) [answer](#) [solution](#)Use a quadratic approximation to estimate $\log(0.93)$.(Remember we use $\log x$ to mean the natural logarithm of x , $\log_e x$.)

Q[4]:

[hint](#) [answer](#) [solution](#)Use a quadratic approximation to estimate $\cos\left(\frac{1}{15}\right)$.

Q[5]:

[hint](#) [answer](#) [solution](#)Calculate the quadratic approximation of $f(x) = e^{2x}$ about $x = 0$.

Q[6]:

[hint](#) [answer](#) [solution](#)Use a quadratic approximation to estimate $5^{\frac{4}{3}}$.

Q[7]:

[hint](#) [answer](#) [solution](#)

Evaluate the expressions below.

(a)
$$\sum_{n=5}^{30} 1$$

(b)
$$\sum_{n=1}^3 [2(n+3) - n^2]$$

(c)
$$\sum_{n=1}^{10} \left[\frac{1}{n} - \frac{1}{n+1} \right]$$

(d)
$$\sum_{n=1}^4 \frac{5 \cdot 2^n}{4^{n+1}}$$

Q[8]:

[hint](#) [answer](#) [solution](#)

Write the following in sigma notation:

(a) $1 + 2 + 3 + 4 + 5$

(b) $2 + 4 + 6 + 8$

(c) $3 + 5 + 7 + 9 + 11$

(d) $9 + 16 + 25 + 36 + 49$

(e) $9 + 4 + 16 + 5 + 25 + 6 + 36 + 7 + 49 + 8$

(f) $8 + 15 + 24 + 35 + 48$

(g) $3 - 6 + 9 - 12 + 15 - 18$

►► Stage 3

Q[9]:

[hint](#) [answer](#) [solution](#)Use a quadratic approximation of $f(x) = 2 \arcsin x$ about $x = 0$ to approximate $f(1)$. What number are you approximating?

Q[10]:

[hint](#) [answer](#) [solution](#)Use a quadratic approximation of e^x to estimate e as a decimal.

Q[11]:

[hint](#) [answer](#) [solution](#)

Group the expressions below into collections of equivalent expressions.

(a)
$$\sum_{n=1}^{10} 2n$$

(b)
$$\sum_{n=1}^{10} 2^n$$

(c) $\sum_{n=1}^{10} n^2$

(d) $2 \sum_{n=1}^{10} n$

(e) $2 \sum_{n=2}^{11} (n-1)$

(f) $\sum_{n=5}^{14} (n-4)^2$

(g) $\frac{1}{4} \sum_{n=1}^{10} \left(\frac{4^{n+1}}{2^n} \right)$

9.4▲ Still Better approximations

Exercises

Jump to [HINTS](#), [ANSWERS](#), [SOLUTIONS](#) or [TABLE OF CONTENTS](#).

►► Stage 1

Q[1]:

The 3rd degree Taylor polynomial for a function $f(x)$ about $x = 1$ is

[hint](#) [answer](#) [solution](#)

$$T_3(x) = x^3 - 5x^2 + 9x$$

What is $f''(1)$?

Q[2]:

The n th degree Taylor polynomial for $f(x)$ about $x = 5$ is

[hint](#) [answer](#) [solution](#)

$$T_n(x) = \sum_{k=0}^n \frac{2k+1}{3k-9} (x-5)^k$$

What is $f^{(10)}(5)$?

►► Stage 3

Q[3]:

The 4th-degree Maclaurin polynomial for $f(x)$ is

[hint](#) [answer](#) [solution](#)

$$T_4(x) = x^4 - x^3 + x^2 - x + 1$$

What is the third-degree Maclaurin polynomial for $f(x)$?

Q[4]:

[hint](#) [answer](#) [solution](#)The 4th degree Taylor polynomial for $f(x)$ about $x = 1$ is

$$T_4(x) = x^4 + x^3 - 9$$

What is the third degree Taylor polynomial for $f(x)$ about $x = 1$?

Q[5]:

[hint](#) [answer](#) [solution](#)For any even number n , suppose the n th degree Taylor polynomial for $f(x)$ about $x = 5$ is

$$\sum_{k=0}^{n/2} \frac{2k+1}{3k-9} (x-5)^{2k}$$

What is $f^{(10)}(5)$?

Q[6]:

[hint](#) [answer](#) [solution](#)The third-degree Taylor polynomial for $f(x) = x^3 \left[2 \log x - \frac{11}{3} \right]$ about $x = a$ is

$$T_3(x) = -\frac{2}{3} \sqrt{e^3} + 3ex - 6\sqrt{e}x^2 + x^3$$

What is a ?

9.5▲ Some examples

Exercises

Jump to [HINTS](#), [ANSWERS](#), [SOLUTIONS](#) or [TABLE OF CONTENTS](#).

►► Stage 2

Q[1]:

[hint](#) [answer](#) [solution](#)Give the 16th degree Maclaurin polynomial for $f(x) = \sin x + \cos x$.

Q[2]:

[hint](#) [answer](#) [solution](#)Give the 100th degree Taylor polynomial for $s(t) = 4.9t^2 - t + 10$ about $t = 5$.

Q[3]:

[hint](#) [answer](#) [solution](#)Write the n th-degree Taylor polynomial for $f(x) = 2^x$ about $x = 1$ in sigma notation.

Q[4]:

[hint](#) [answer](#) [solution](#)Find the 6th degree Taylor polynomial of $f(x) = x^2 \log x + 2x^2 + 5$ about $x = 1$, remembering that $\log x$ is the natural logarithm of x , $\log_e x$.

Q[5]:

[hint](#) [answer](#) [solution](#)Give the n th degree Maclaurin polynomial for $\frac{1}{1-x}$ in sigma notation.

►► Stage 3

Q[6]:

[hint](#) [answer](#) [solution](#)Calculate the 3rd-degree Taylor Polynomial for $f(x) = x^x$ about $x = 1$.

Q[7]: [hint](#) [answer](#) [solution](#)

Use a 5th-degree Maclaurin polynomial for $6 \arctan x$ to approximate π .

Q[8]: [hint](#) [answer](#) [solution](#)

Write the 100th-degree Taylor polynomial for $f(x) = x(\log x - 1)$ about $x = 1$ in sigma notation.

Q[9]: [hint](#) [answer](#) [solution](#)

Write the $(2n)$ th-degree Taylor polynomial for $f(x) = \sin x$ about $x = \frac{\pi}{4}$ in sigma notation.

Q[10]: [hint](#) [answer](#) [solution](#)

Estimate the sum below

$$1 + \frac{1}{2} + \frac{1}{3!} + \frac{1}{4!} + \cdots + \frac{1}{157!}$$

by interpreting it as a Maclaurin polynomial.

Q[11]: [hint](#) [answer](#) [solution](#)

Estimate the sum below

$$\sum_{k=0}^{100} \frac{(-1)^k}{2k!} \left(\frac{5\pi}{4}\right)^{2k}$$

by interpreting it as a Maclaurin polynomial.

9.6▲ (Flavour A) Error in Taylor polynomials

Exercises

Jump to [HINTS](#), [ANSWERS](#), [SOLUTIONS](#) or [TABLE OF CONTENTS](#).

►► Stage 1

Q[1]: [hint](#) [answer](#) [solution](#)

Suppose $f(x)$ is a function that we approximated by $F(x)$. Further, suppose $f(10) = -3$, while our approximation was $F(10) = 5$. Let $R(x) = f(x) - F(x)$.

- (a) True or false: $|R(10)| \leq 7$
- (b) True or false: $|R(10)| \leq 8$
- (c) True or false: $|R(10)| \leq 9$
- (d) True or false: $|R(10)| \leq 100$

Q[2]: [hint](#) [answer](#) [solution](#)

Let $f(x) = e^x$, and let $T_3(x)$ be the third-degree Maclaurin polynomial for $f(x)$,

$$T_3(x) = 1 + x + \frac{1}{2}x^2 + \frac{1}{3!}x^3$$

Use Equation 9.6.6 to give a reasonable bound on the error $|f(2) - T_3(2)|$. Then, find the error $|f(2) - T_3(2)|$ using a calculator.

Q[3]: [hint](#) [answer](#) [solution](#)

Let $f(x) = 5x^3 - 24x^2 + ex - \pi^4$, and let $T_5(x)$ be the fifth-degree Taylor polynomial for $f(x)$ about $x = 1$. Give the best bound you can on the error $|f(37) - T(37)|$.

Q[4]:

[hint](#) [answer](#) [solution](#)

You and your friend both want to approximate $\sin(33)$. Your friend uses the first-degree Maclaurin polynomial for $f(x) = \sin x$, while you use the zeroth-degree (constant) Maclaurin polynomial for $f(x) = \sin x$. Who has a better approximation, you or your friend?

►► Stage 2

Q[5]:

[hint](#) [answer](#) [solution](#)

Suppose a function $f(x)$ has sixth derivative

$$f^{(6)}(x) = \frac{6!(2x-5)}{x+3}.$$

Let $T_5(x)$ be the 5th-degree Taylor polynomial for $f(x)$ about $x = 11$.

Give a bound for the error $|f(11.5) - T_5(11.5)|$.

Q[6]:

[hint](#) [answer](#) [solution](#)

Let $f(x) = \tan x$, and let $T_2(x)$ be the second-degree Taylor polynomial for $f(x)$ about $x = 0$. Give a reasonable bound on the error $|f(0.1) - T(0.1)|$ using Equation 9.6.6.

Q[7]:

[hint](#) [answer](#) [solution](#)

Let $f(x) = \log(1-x)$, and let $T_5(x)$ be the fifth-degree Maclaurin polynomial for $f(x)$. Use Equation 9.6.6 to give a bound on the error $|f(-\frac{1}{4}) - T_5(-\frac{1}{4})|$.

(Remember $\log x = \log_e x$, the natural logarithm of x .)

Q[8]:

[hint](#) [answer](#) [solution](#)

Let $f(x) = \sqrt[5]{x}$, and let $T_3(x)$ be the third-degree Taylor polynomial for $f(x)$ about $x = 32$. Give a bound on the error $|f(30) - T_3(30)|$.

Q[9]:

[hint](#) [answer](#) [solution](#)

Let

$$f(x) = \sin\left(\frac{1}{x}\right)$$

and let $T_1(x)$ be the first-degree Taylor polynomial for $f(x)$ about $x = \frac{1}{\pi}$. Give a bound on the error $|f(0.01) - T_1(0.01)|$, using Equation 9.6.6. You may leave your answer in terms of π .

Then, give a *reasonable* bound on the error $|f(0.01) - T_1(0.01)|$.

Q[10]:

[hint](#) [answer](#) [solution](#)

Let $f(x) = \arcsin x$, and let $T_2(x)$ be the second-degree Maclaurin polynomial for $f(x)$. Give a reasonable bound on the error $|f(\frac{1}{2}) - T_2(\frac{1}{2})|$ using Equation 9.6.6. What is the exact value of the error $|f(\frac{1}{2}) - T_2(\frac{1}{2})|$?

►► Stage 3

Q[11]:

[hint](#) [answer](#) [solution](#)

Let $f(x) = \log(x)$, and let $T_n(x)$ be the n th-degree Taylor polynomial for $f(x)$ about $x = 1$. You use $T_n(1.1)$ to estimate $\log(1.1)$. If your estimation needs to have an error of no more than 10^{-4} , what is an acceptable value of n to use?

Q[12]:

[hint](#) [answer](#) [solution](#)

Give an estimation of $\sqrt[7]{2200}$ using a Taylor polynomial. Your estimation should have an error of less than 0.001.

Q[13]:

[hint](#) [answer](#) [solution](#)

Use Equation 9.6.6 to show that

$$\frac{4241}{5040} \leq \sin(1) \leq \frac{4243}{5040}$$

Q[14]:

[hint](#) [answer](#) [solution](#)

In this question, we use the remainder of a Maclaurin polynomial to approximate e .

- (a) Write out the 4th degree Maclaurin polynomial $T_4(x)$ of the function e^x .
- (b) Compute $T_4(1)$.

- (c) Use your answer from (b) to conclude $\frac{326}{120} < e < \frac{325}{119}$.

Chapter 10

(FLAVOUR A) NEWTON'S METHOD**Exercises**

Jump to [HINTS](#), [ANSWERS](#), [SOLUTIONS](#) or [TABLE OF CONTENTS](#).

Q[1]: [answer](#)
Starting at $x_0 = 3$, use two iterations of Newton's method to approximate the root of $f(x) = x^2 - 10$. You may leave your answer in calculator-ready form.

Q[2]: [answer](#)
Starting at $x_0 = 3$, use one iteration of Newton's method to approximate the root of $f(x) = x^3 - 30$. Express your answer as a simplified fraction. Then, check that you're on the right path by cubing your answer with a calculator.

Q[3]: [answer](#) [solution](#)
Use two iterations of Newton's method to approximate the x -value of the critical point of the function $g(x) = x - x^2 - x^4$.

Q[4]: [answer](#) [solution](#)
Use one iteration of Newton's method to approximate the value of x where $\arctan x = x - 10$. Leave your answer in calculator-ready form.

Q[5]: [answer](#) [solution](#)
Use two iterations of Newton's method to approximate a root of the function

$$f(x) = x^3 - 12x + 15$$

close to $x = 2$. Leave your answer in calculator-ready form.

Q[6]: [answer](#)
Use one iteration of Newton's method to find an approximate value for $\sqrt{8}$ that is a rational number. (*Hint*: first think of a function, $f(x)$, such that $f(x) = 0$ has the solution $x = \sqrt{8}$.)

Q[7]: [answer](#)
Approximate the root of $x^3 + 3x - 1 = 0$ using two iterations of Newton's method.

Q[8]: [answer](#)
Approximate the root of $x^3 + x^2 + x - 2 = 0$ using one iterations of Newton's method.

Q[9]:

[hint](#) [answer](#)

Use the method of linear approximation (i.e. one iteration of Newton's method) to find the cube root of:

- (a) 0.065
- (b) 215

Chapter 11

**(FLAVOURS A, B) INTRODUCTION
TO DIFFERENTIAL EQUATIONS****Exercises**

Jump to [HINTS](#), [ANSWERS](#), [SOLUTIONS](#) or [TABLE OF CONTENTS](#).

These questions are adapted from Keshet, Chapter 11. The selected answers provided here are used with permission. Many answers are given in exact terms, e.g. “ $\frac{10}{3} \log 8$,” as well as with decimal approximations. You should be able to solve all questions exactly *without* use of a calculator; the decimal approximations are included because they are easier to understand in the context of a model.

Q[1]:

[answer](#)

A colony of bacteria is treated with a mild antibiotic agent so that the bacteria start to die. It is observed that the population of bacteria as a function of time follows the approximate relationship $b(t) = 85e^{-0.5t}$ where t is time in hours.

Determine the time it takes for half of the bacteria to die; this is called the *half-life*.

Find how long it takes for 99% of the bacteria to die.

Q[2]:

A differential equation is an equation in which some function is related to its own derivative(s).

For each of the following functions, calculate the appropriate derivative, and show that the function satisfies the indicated differential equation.

(a) $f(x) = 2e^{-3x}$, $f'(x) = -3f(x)$

(b) $f(t) = Ce^{kt}$, $f'(t) = kf(t)$

(c) $f(t) = 1 - e^{-t}$, $f'(t) = 1 - f(t)$

Q[3]:

[answer](#)

Consider the function $y = f(t) = Ce^{kt}$ where C and k are constants. For what value(s) of these constants does this function satisfy the equations below?

(a) $\frac{dy}{dt} = -5y,$

(b) $\frac{dy}{dt} = 3y$

Q[4]:

Check that the function

$$N(t) = N_0 e^{kt} = N_0 e^{(r-m)t}$$

satisfies the differential equation

$$\frac{dN}{dt} = (r - m)N$$

and the initial condition $N(0) = N_0$.

Q[5]:

answer

Find a function that satisfies each of the following differential equations.

Note: all your answers should be exponential functions, but they may have different dependent and independent variables. Question 2 may help.

(a) $\frac{dy}{dt} = -y,$

(b) $\frac{dc}{dx} = -0.1c$ and $c(0) = 20,$

(c) $\frac{dz}{dt} = 3z$ and $z(0) = 5.$

Q[6]:

answer

The per capita birthrate of one species of rodent is 0.05 newborns per day. This means that, on average, each member of the population results in 5 newborn rodents every 100 days. Suppose that over the period of 1000 days there are no deaths, and that the initial population of rodents is 250.

- Write a differential equation for the population size $N(t)$ at time t (in days).
- Write down the initial condition that N satisfies.
- Find the solution, i.e. express N as some function of time t that satisfies your differential equation and initial condition.
- How many rodents are there after 1 year ?

Q[7]:

answer

Suppose a population of bacteria starts from a single bacterium, and grows at a rate proportional to the number of bacteria in the population. Suppose further that it takes 20 minutes for the population to double.

Find the appropriate differential equation that describes this growth, the appropriate initial condition, and the exponential function that is the solution to that differential equation. Use units of hours for time t .

Q[8]:

In Canada, women have only about 2 children during their 40 years of fertility, and people live to age 80. In underdeveloped countries, people on average live to age 60 and women have a child roughly every 4 years between ages 13 and 45.

Compare the per capita birth and mortality rates and the predicted population growth or decay in each of these scenarios, using arguments analogous to those of Section 11.2.

Find the growth rate k in percent per year and the doubling time for the growing population.

Q[9]:

answer

A population of animals has a per-capita birth rate of $b = 0.08$ per year and a per-capita death rate of $m = 0.01$ per year. The population density, $P(t)$ is found to satisfy the differential equation

$$\frac{dP(t)}{dt} = bP(t) - mP(t)$$

- (a) If the population is initially $P(0) = 1000$, find how big the population is in 5 years.
- (b) When does the population double?

Q[10]:

answer

- (a) The population $y(t)$ of a certain microorganism grows continuously and follows an exponential behaviour over time. Its doubling time is found to be 0.27 hours. What differential equation would you use to describe its growth?

Note: you must find the value of the rate constant, k , using the doubling time.

- (b) With exposure to ultra-violet radiation, the population ceases to grow, and the microorganisms continuously die off. It is found that the half-life is then 0.1 hours. What differential equation would now describe the population?

Q[11]:

answer

A bacterial population grows at a rate proportional to the population size at time t . Let $y(t)$ be the population size at time t . By experiment it is determined that the population at $t = 10$ min is 15,000 and at $t = 30$ min it is 20,000.

- (a) What was the initial population?
- (b) What is the population at time $t = 60$ min?

Q[12]:

answer

Two populations are studied. Population 1 is found to obey the differential equation

$$\frac{dy_1}{dt} = 0.2y_1$$

and population 2 obeys

$$\frac{dy_2}{dt} = -0.3y_2$$

where t is time in years.

- (a) Which population is growing and which is declining?
 - (b) Find the doubling time (respectively half-life) associated with the given population.
 - (c) If the initial levels of the two populations were $y_1(0) = 100$ and $y_2(0) = 10,000$, how big would each population be at time t ?
 - (d) At what time would the two populations be exactly equal?
-

Q[13]: answer
 The human population on Earth doubles roughly every 50 years. In October 2000 there were 6.1 billion humans on earth.

- (a) Determine what the human population would be 500 years later under the uncontrolled growth scenario.
- (b) How many people would have to inhabit each square kilometer of the planet for this population to fit on earth? (Take the circumference of the earth to be 40,000 km for the purpose of computing its surface area and assume that the oceans have dried up.)

Q[14]: answer
 Two lakes have populations of fish, but the conditions are quite different in these lakes. In the first lake, the fish population is growing and satisfies the differential equation

$$\frac{dy}{dt} = 0.2y$$

where t is time in years. At time $t = 0$ there were 500 fish in this lake. In the second lake, the population is dying due to pollution. Its population satisfies the differential equation

$$\frac{dy}{dt} = -0.1y,$$

and initially there were 4000 fish in this lake.

At what time are the fish populations in the two lakes identical?

Q[15]: answer
 When chemists say that a chemical reaction follows “first order kinetics”, they mean that the concentration of the reactant at time t , i.e. $c(t)$, satisfies an equation of the form $\frac{dc}{dt} = -rc$ where r is a rate constant, here assumed to be positive. Suppose the reaction mixture initially has concentration 1M (“1 molar”) and that after 1 hour there is half this amount.

- (a) Find the “half life” of the reactant.
- (b) Find the value of the rate constant r .
- (c) Determine how much is left after 2 hours.
- (d) When is only 10% of the initial amount be left?

Q[16]: answer
 In a chemical reaction, a substance S is broken down. The concentration of the substance is observed to change at a rate proportional to the current concentration. It was observed that 1 Mole/litre of S decreased to 0.5 Moles/litre in 10 minutes.

- (a) How long does it take until only 0.25 Moles per litre remain?
- (b) How long does it take until only 1% of the original concentration remains?

Q[17]: answer
 If 10% of a radioactive substance remains after one year, find its half-life.

Q[18]: answer

Carbon 14. Carbon 14, or ^{14}C , has a half-life of 5730 years. This means that after 5730 years, a sample of Carbon 14, which is a radioactive isotope of carbon, has lost one half of its original radioactivity.

- (a) Estimate how long it takes for the sample to fall to roughly 0.001 of its original level of radioactivity.
- (b) Each gram of ^{14}C has an activity given here in units of 12 decays per minute. After some time, the amount of radioactivity decreases. For example, a sample 5730 years old has only one half the original activity level, i.e. 6 decays per minute. If a 1 gm sample of material is found to have 45 decays per hour, approximately how old is it?

Note: ^{14}C is used in radiocarbon dating, a process by which the age of materials containing carbon can be estimated. W. Libby received the Nobel prize in chemistry in 1960 for developing this technique.

Q[19]:

[answer](#)

Strontium-90 is a radioactive isotope with a half-life of 29 years. If you begin with a sample of 800 units, how long does it take for the amount of radioactivity of the strontium sample to be reduced to:

- (a) 400 units?
- (b) 200 units?
- (c) 1 unit?

Q[20]:

[answer](#)

Cobalt 60 is a radioactive substance with half life 5.3 years. It is used in medical applications (radiology). How long does it take for 80% of a sample of this substance to decay?

Q[21]:

[hint](#) [answer](#)

A barrel initially contains 2 kg of salt dissolved in 20 L of water. If water flows in at the rate of 0.4 L per minute and the well-mixed salt water solution flows out at the same rate, how much salt is present after 8 minutes?

Q[22]:

[answer](#)

Assume the atmospheric pressure y at a height x meters above the sea level satisfies the relation

$$\frac{dy}{dx} = ky$$

for some constant k . If one day at a certain location the atmospheric pressures are 760 and 675 torr (unit for pressure) at sea level and at 1000 meters above sea level, respectively, find the value of the atmospheric pressure at 600 meters above sea level.

Chapter 12

**(FLAVOURS A, B) SOLVING
DIFFERENTIAL EQUATIONS****Exercises**

Jump to [HINTS](#), [ANSWERS](#), [SOLUTIONS](#) or [TABLE OF CONTENTS](#).

Questions 1 through 19 are from Keshet, Chapter 12, which intentionally omits some answers.

Q[1]: [answer](#)

Euler's method. Solve the decay equation in Example 12.3.2 in the text analytically. That is, find the formula for the solution to

$$\frac{dy}{dt} = -0.5y, y(0) = 100$$

in terms of a decaying exponential, and then use a calculator to compare your values to the approximate solution values y_1 and y_2 computed with Euler's method in Table 12.3 in the text.

Q[2]: [answer](#)

Comparing approximate and true solutions. For this question, you may use a calculator.

(a) Use Euler's method to find an approximate solution to the differential equation

$$\frac{dy}{dx} = y$$

with $y(0) = 1$. Use a step size $h = 0.1$ and find the values of y up to $x = 0.5$. Compare the value you have calculated for $y(0.5)$ using Euler's method with the true solution of this differential equation. What is the **error** i.e. the difference between the true solution and the approximation?

(b) Now use Euler's method on the differential equation

$$\frac{dy}{dx} = -y$$

with $y(0) = 1$. Use a step size $h = 0.1$ again and find the values of y up to $x = 0.5$. Compare the value you have calculated for $y(0.5)$ using Euler's method with the true solution of this differential equation. What is the error this time?

Q[3]:

Beginning Euler's method. Give the first 3 steps of Euler's method for the problem in Example 12.3.4 in the text.

Q[4]:

answer

Water draining from a container. In Example 12.1.3 in the text, we verified that the function $h(t) = (\sqrt{h_0} - k\frac{t}{2})^2$ is a solution to the differential equation

$$\frac{dh}{dt} = -k\sqrt{h}.$$

Based on the meaning of the problem, for how long does this solution remain valid?

Q[5]:

Verifying a solution. Verify that the function $y(t) = 1 - (1 - y_0)e^{-t}$ satisfies the initial value problem (differential equation and initial condition)

$$\frac{dy}{dt} = 1 - y, \quad y(0) = y_0$$

(equation 12.2.3 in the text).

Q[6]:

Linear differential equation. Consider the differential equation

$$\frac{dy}{dt} = a - by$$

where a, b are constants.

(a) Show that the function

$$y(t) = \frac{a}{b} - Ce^{-bt}$$

satisfies the above differential equation for any constant C .

(b) Show that by setting

$$C = \frac{a}{b} - y_0$$

we also satisfy the initial condition

$$y(0) = y_0.$$

Remark: you have shown that the function

$$y(t) = \left(y_0 - \frac{a}{b}\right)e^{-bt} + \frac{a}{b}$$

is a solution to the *initial value problem* (i.e differential equation plus initial condition)

$$\frac{dy}{dt} = a - by, \quad y(0) = y_0.$$

Q[7]:

Verifying a solution. Show that the function

$$y(t) = \frac{1}{1-t}$$

is a solution to the differential equation and initial condition

$$\frac{dy}{dt} = y^2, \quad y(0) = 1.$$

Comment on what happens to this solution as t approaches 1.

Q[8]:

Verifying solutions. For each of the following, show the given function y is a solution to the given differential equation.

(a) $t \cdot \frac{dy}{dt} = 3y, y = 2t^3.$

(b) $\frac{d^2y}{dt^2} + y = 0, y = -2 \sin t + 3 \cos t.$

(c) $\frac{d^2y}{dt^2} - 2\frac{dy}{dt} + y = 6e^t, y = 3t^2 e^t.$

Q[9]:

Verifying a solution. Show the function determined by the equation $2x^2 + xy - y^2 = C$, where C is a constant and $2y \neq x$, is a solution to the differential equation $(x - 2y)\frac{dy}{dx} = -4x - y.$

Q[10]:

answer

Determining the constant. Find the constants $C, C_1,$ and/or C_2 that satisfy the given initial conditions.

(a) $2x^2 - 3y^2 = C, y|_{x=0} = 2.$

(b) $y = C_1 e^{5t} + C_2 t e^{5t}, y|_{t=0} = 1$ and $\frac{dy}{dt}|_{t=0} = 0.$

(c) $y = C_1 \cos(t - C_2), y|_{t=\frac{\pi}{2}} = 0$ and $\frac{dy}{dt}|_{t=\frac{\pi}{2}} = 1.$

Q[11]:

Checking a solution. Check that the differential equation (12.2.4) has the right sign, so that a hot object cools off in a colder environment.

That is:

$$\frac{dT}{dt} = k(E - T(t)), \quad \text{where } k > 0$$

describes the change in temperature T of an object over time, where E is the (constant) temperature of the environment, and k is a constant.

Q[12]:

answer

Infant weight gain. During the first year of its life, the weight of a baby is given by

$$y(t) = \sqrt{3t + 64}$$

where t is measured in some convenient unit.

(a) Show that y satisfies the differential equation

$$\frac{dy}{dt} = \frac{k}{y}$$

where k is some positive constant.

(b) What is the value for k ?

(c) Suppose we adopt this differential equation as a model for human growth. State concisely (that is, in one sentence) one feature about this differential equation which makes it a reasonable model. State one feature which makes it unreasonable.

Q[13]:

[answer](#)

Lake Fishing. Fish Unlimited is a company that manages the fish population in a private lake. They restock the lake (that is, they add fish to the lake) at constant rate. N fishers are allowed to fish in the lake per day. The population of fish in the lake, $F(t)$ is found to satisfy the differential equation

$$\frac{dF}{dt} = I - \alpha NF \tag{12.0.1}$$

where F is measured in individual fish, and t is measured in days.

(a) At what rate are fish added per day according to Eqn. (12.0.1)? Give both value and units.

(b) What is the average number of fish caught by one fisher? Give both the value and units.

(c) What is being assumed about the fish birth and mortality rates in Eqn. (12.0.1)?

(d) If the fish input and number of fishers are constant, what is the steady state level of the fish population in the lake?

(e) At time $t = 0$ the company stops restocking the lake with fish. Give the revised form of the differential equation (12.0.1) that takes this into account, assuming the same level of fishing as before. How long would it take for the fish to fall to 25% of their initial level?

(f) When the fish population drops to the level F_{low} , fishing is stopped and the lake is restocked with fish at the same constant rate (Eqn (12.0.1), with $\alpha = 0$.) Write down the revised version of Eqn. (12.0.1) that takes this into account. How long would it take for the fish population to double?

Q[14]:

Tissue culture. Cells in a tissue culture produce a cytokine (a chemical that controls the growth of other cells) at a constant rate of 10 nano-Moles per hour (nM/h). The chemical has a half-life of 20 hours.

Give a differential equation (DE) that describes this chemical production and decay. Solve this DE assuming that at $t = 0$ there is no cytokine. [1nM=10⁻⁹M].

Q[15]:

[answer](#)

Glucose solution in a tank. A tank that holds 1 liter is initially full of plain water. A concentrated solution of glucose, containing 0.25 gm/cm³ is pumped into the tank continuously, at the rate 10 cm³/min and the mixture (which is continuously stirred to keep it uniform) is pumped out at the same rate.

Let $G(t)$ be the amount of glucose in the tank after t minutes. Write a differential equation for G , and give its initial condition.

How much glucose is in the tank after a long time?

Q[16]:

[answer](#)

Pollutant in a lake. A lake of constant volume V gallons contains $Q(t)$ pounds of pollutant at time t evenly distributed throughout the lake. Water containing a concentration of k pounds per gallon of pollutant enters the lake at a rate of r gallons per minute, and the well-mixed solution leaves at the same rate.

- Set up a differential equation that describes the way that the amount of pollutant in the lake changes.
- Determine what happens to the pollutant level after a long time if this process continues.
- If $k = 0$ find the time T for the amount of pollutant to be reduced to one half of its initial value.

Q[17]:

[answer](#)

A sugar solution. Sugar dissolves in water at a rate proportional to the amount of sugar not yet in solution. Let $Q(t)$ be the amount of sugar undissolved at time t . The initial amount is 100 kg and after 4 hours the amount undissolved is 70 kg.

- Find a differential equation for $Q(t)$ and solve it.
- How long does it take for 50 kg to dissolve?

Q[18]:

[answer](#)

Leaking water tank. A cylindrical tank with cross-sectional area A has a small hole through which water drains. The height of the water in the tank $y(t)$ at time t is given by:

$$y(t) = \left(\sqrt{y_0} - \frac{kt}{2A} \right)^2$$

where k, y_0 are constants.

- Show that the height of the water, $y(t)$, satisfies the differential equation

$$\frac{dy}{dt} = -\frac{k}{A}\sqrt{y}.$$

- What is the initial height of the water in the tank at time $t = 0$?
- At what time is the tank be empty ?
- At what rate is the **volume** of the water in the tank changing when $t = 0$?

Q[19]:

[answer](#)

Determining constants. Find those constants a, b so that $y = e^x$ and $y = e^{-x}$ are both solutions of the differential equation

$$y'' + ay' + by = 0.$$

Q[20]:

[answer](#)Approximate $y(0.5)$ if $y(t)$ satisfies the differential equation

$$\frac{dy}{dt} = \frac{y^2 - 1}{y^2 + 1}$$

and the initial condition

$$y(0) = 0$$

using a (simple) calculator or a spreadsheet, and the following step sizes in Euler's method.

- Approximate $y(0.5)$ using $\Delta t = 0.5$.
- Approximate $y(0.5)$ using $\Delta t = 0.25$.
- Approximate $y(0.5)$ using $\Delta t = 0.1$.

Q[21]:

[answer](#) [solution](#)

Given the initial-value problem

$$\frac{dy}{dt} = y - t, \quad y(0) = 0$$

use Euler's method with three steps to approximate $y(0.03)$.

Q[22]:

[answer](#) [solution](#)

Given the initial-value problem

$$\frac{dy}{dt} = y + t, \quad y(0) = 0$$

use Euler's method with three steps to approximate $y(0.03)$. You may use a (simple) calculator or a spreadsheet.

Q[23]:

[answer](#)

Given the initial-value problem

$$\frac{dy}{dt} = \frac{t}{y}, \quad y(0) = 1$$

use Euler's method with three steps to approximate $y(0.03)$. You may use a (simple) calculator or a spreadsheet.

Q[24]:

[answer](#) [solution](#)

Given the initial-value problem

$$\frac{dy}{dt} = \sqrt{t}, \quad y(0) = 0$$

use Euler's method with two steps to approximate $y(1)$.

Q[25]:

[answer](#) [solution](#)

Given the initial-value problem

$$\frac{dy}{dt} = \sqrt{y}, \quad y(0) = 0$$

use Euler's method with two steps to approximate $y(1)$.

Q[26]:

[answer](#) [solution](#)

Given the initial-value problem

$$\frac{dy}{dt} = \sqrt{y}, \quad y(2) = 1$$

use Euler's method with two steps to approximate $y(3)$.

Q[27]:

[answer](#) [solution](#)

Suppose $y(1.1) = \frac{1}{7}$ and

$$\frac{dy}{dt} = \frac{y}{t}.$$

Use three steps of Euler's method to approximate $y(1.5)$. You may use a (simple) calculator or a spreadsheet.

Chapter 13

(FLAVOURS A, B) QUALITATIVE METHODS FOR DIFFERENTIAL EQUATIONS

Exercises

Jump to [HINTS](#), [ANSWERS](#), [SOLUTIONS](#) or [TABLE OF CONTENTS](#).

Q[1]:

[answer](#)

Slope fields. Consider the differential equations given below. In each case, draw a slope field, determine the values of y for which no change takes place - such values are called steady states - and use your slope field to predict what would happen starting from an initial value $y(0) = 1$.

(a) $\frac{dy}{dt} = -0.5y$

(b) $\frac{dy}{dt} = 0.5y(2 - y)$

(c) $\frac{dy}{dt} = y(2 - y)(3 - y)$

Q[2]:

[answer](#)

Drawing slope fields. Draw a slope field for each of the given differential equations:

(a) $\frac{dy}{dt} = 2 + 3y$

(b) $\frac{dy}{dt} = -y(2 - y)$

(c) $\frac{dy}{dt} = 2 - 3y + y^2$

(d) $\frac{dy}{dt} = -2(3 - y)^2$

(e) $\frac{dy}{dt} = y^2 - y + 1$

(f) $\frac{dy}{dt} = y^3 - y$

(g) $\frac{dy}{dt} = \sqrt{y}(y - 2)(y - 3)^2, y \geq 0.$

Flavour B

Q[3]:

answer

Using slope fields. For each of the differential equations (a) to (g) in Exercise 2, plot $\frac{dy}{dt}$ as a function of y , draw the motion along the y -axis, identify the steady state(s) and indicate if the motions are toward or away from the steady state(s).

Q[4]:

answer

Slope field. The slope field shown in the figure below corresponds to which differential equation?

- (A) $\frac{dy}{dt} = ry(y+1)$
 (B) $\frac{dy}{dt} = r(y-1)(y+1)$
 (C) $\frac{dy}{dt} = -r(y-1)(y+1)$
 (D) $\frac{dy}{dt} = ry(y-1)$
 (E) $\frac{dy}{dt} = -ry(y+1)$

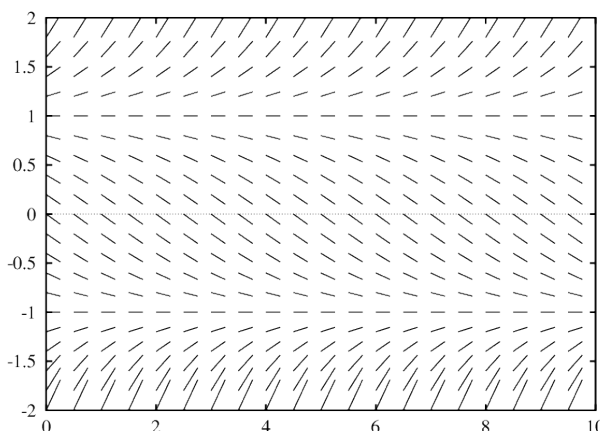

Q[5]:

answer

Differential equation. Given the differential equation and initial condition

$$\frac{dy}{dt} = y^2(y - a), \quad y(0) = 2a$$

where $a > 0$ is a constant, the value of the function $y(t)$ would

- (A) approach $y = 0$;
 (B) grow larger with time;
 (C) approach $y = a$;
 (D) stay the same;
 (E) none of the above.

Q[6]:

answer

There's a hole in the bucket. Water flows into a bucket at constant rate I . There is a hole in the container. Explain the model

$$\frac{dh}{dt} = I - k\sqrt{h}.$$

Analyze the behaviour predicted. What would the height be after a long time? Is this result always valid, or is an additional assumption needed? (*hint*: recall Example 12.1.3 in the text.)

Flavour B

Q[7]:

[hint](#) [answer](#)

Cubical crystal. A crystal grows inside a medium in a cubical shape with side length x and volume V . The rate of change of the volume is given by

$$\frac{dV}{dt} = kx^2(V_0 - V)$$

where k and V_0 are positive constants.

- Rewrite this as a differential equation for $\frac{dx}{dt}$.
- Suppose that the crystal grows from a very small “seed.” Show that its growth rate continually decreases.
- What happens to the size of the crystal after a very long time?
- What is its volume when x it is growing at half its initial rate, assuming the initial value of x is close to 0?

Q[8]:

The Law of Mass Action. The Law of Mass Action in Section 13.1 led to the assumption that the rate of a reaction involving two types of molecules (A and B) is proportional to the product of their concentrations, $k \cdot a \cdot b$.

Explain why the sum of the concentrations, $k \cdot (a + b)$, would not make for a sensible assumption about the rate of the reaction.

Q[9]:

[answer](#)

Biochemical reaction. A biochemical reaction in which a substance S is both produced and consumed is investigated. The concentration $c(t)$ of S changes during the reaction, and is seen to follow the differential equation

$$\frac{dc}{dt} = K_{\max} \frac{c}{k + c} - rc$$

where K_{\max}, k, r are positive constants with certain convenient units. The first term is a concentration-dependent production term and the second term represents consumption of the substance.

- What is the maximal rate at which the substance is produced? At what concentration is the production rate 50% of this maximal value?
- If the production is turned off, the substance decays. How long would it take for the concentration to drop by 50%?
- At what concentration does the production rate just balance the consumption rate?

Flavour B

Q[10]:

Logistic growth with proportional harvesting. Consider a fish population of density $N(t)$

growing at rate $g(N)$, with harvesting, so that the population satisfies the differential equation

$$\frac{dN}{dt} = g(N) - h(N).$$

Now assume that the growth rate is logistic, so $g(N) = rN\frac{(K-N)}{K}$ where $r, K > 0$ are constant. Assume that the rate of harvesting is proportional to the population size, so that

$$h(N) = qEN$$

where E , the effort of the fishermen, and q , the catchability of this type of fish, are positive constants.

Use qualitative methods discussed in this chapter to analyze the behaviour of this equation. Under what conditions does this lead to a sustainable fishery?

Q[11]:

Logistic growth with constant number harvesting. Consider the same fish population as in Exercise 10, but this time assume that the rate of harvesting is fixed, regardless of the population size, so that

$$h(N) = H$$

where H is a constant number of fish being caught and removed per unit time. Analyze this revised model and compare it to the previous results.

Q[12]:

answer

Scaling time in the logistic equation. Consider the scaled logistic equation 13.1.3

$$\frac{dy}{dt} = ry(1 - y).$$

Recall that r has units of 1/time, so $1/r$ is a quantity with units of time. Now consider scaling the time variable in the displayed equation by defining $t = s/r$. Then s carries no units (s is “dimensionless”).

Substitute this expression for t in the displayed equation and find the differential equation so obtained (for dy/ds).

Flavour B

Q[13]:

Spread of infection. In the model for the spread of a disease (starting page 386 in the text), we used the fact that the total population is constant ($S(t) + I(t) = N = \text{constant}$) to eliminate $S(t)$ and analyze a differential equation for $I(t)$ on its own.

Carry out a similar analysis, but eliminate $I(t)$. Then analyze the differential equation you get for $S(t)$ to find its steady states and behaviour, practicing the qualitative analysis discussed in this chapter.

Flavour B

Q[14]:

answer

Social media. Sally Sweetstone has invented a new social media App called HeadSpace, which instantly matches compatible mates according to their changing tastes and styles. Users hear about the App from one another by word of mouth and sign up for an account. The account expires randomly, with a half-life of 1 month. Suppose $y_1(t)$ are the number of individuals who are not subscribers and $y_2(t)$ are the number of are subscribers at time t . The following model has been suggested for the evolving subscriber population

$$\begin{aligned}\frac{dy_1}{dt} &= by_2 - ay_1y_2, \\ \frac{dy_2}{dt} &= ay_1y_2 - by_2.\end{aligned}$$

- Explain the terms in the equation. What is the value of the constant b ?
- Show that the total population $P = y_1(t) + y_2(t)$ is constant.
Note: this is a **conservation statement**.
- Use the conservation statement to eliminate y_1 . Then analyze the differential equation you obtain for y_2 .
- Use your model to determine whether this newly launched social media will be successful or whether it will go extinct.

Flavour B

Q[15]:

answer

A bimolecular reaction. Two molecules of A can react to form a new chemical, B . The reaction is **reversible** so that B also continually decays back into 2 molecules of A . The differential equation model proposed for this system is

$$\begin{aligned}\frac{da}{dt} &= -\mu a^2 + 2\beta b \\ \frac{db}{dt} &= \frac{\mu}{2} a^2 - \beta b,\end{aligned}$$

where $a(t), b(t) > 0$ are the concentrations of the two chemicals.

- Explain the factor 2 that appears in the differential equations and the conservation statement. Show that the total mass $M = a(t) + 2b(t)$ is constant.
- Use the techniques in this chapter to investigate what happens in this chemical reaction, to find any steady states, and to explain the behaviour of the system

Chapter 14

(FLAVOUR C) GEOMETRY IN THREE DIMENSIONS

14.1▲ Points and planes

Exercises

Jump to [HINTS](#), [ANSWERS](#), [SOLUTIONS](#) or [TABLE OF CONTENTS](#).

►► Stage 1

Q[1]:

[hint](#) [answer](#) [solution](#)

Part of \mathbb{R}^3 is sketched below, along with a triangle.

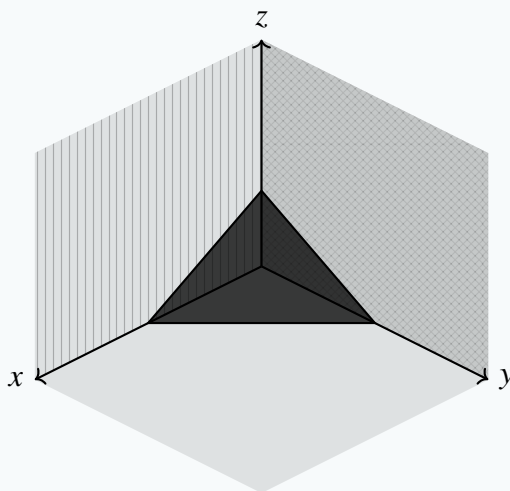

Identify the following parts of the sketch:

- the xy -plane
- the yz -plane
- the xz -plane
- the vertex of the triangle lying on $(1, 0, 0)$
- the vertex of the triangle lying on $(0, 1, 0)$
- the vertex of the triangle lying on $(0, 0, 1)$

Q[2]:

[hint](#) [answer](#) [solution](#)

Describe the set of all points (x, y, z) in \mathbb{R}^3 that satisfy

- $x^2 + y^2 + z^2 = 2x - 4y + 4$
- $x^2 + y^2 + z^2 < 2x - 4y + 4$

Q[3]:

[hint](#) [answer](#) [solution](#)

Describe and sketch the set of all points (x, y) in \mathbb{R}^2 that satisfy

- $x = y$
- $x + y = 1$
- $x^2 + y^2 = 4$
- $x^2 + y^2 = 2y$
- $x^2 + y^2 < 2y$

Q[4]:

[hint](#) [answer](#) [solution](#)

Describe the set of all points (x, y, z) in \mathbb{R}^3 that satisfy the following conditions. Sketch the part of the set that is in the first *octant*. That is, sketch the part of the set with non-negative values of x , y , and z .

- $z = x$

(b) $x^2 + y^2 + z^2 = 4$

(c) $x^2 + y^2 + z^2 = 4, z = 1$

(d) $x^2 + y^2 = 4$

(e) $z = x^2 + y^2$

►► Stage 2

Q[5]:

[hint](#) [answer](#) [solution](#)What is the distance from the point $(1, 2, 3)$ to the point $(4, -5, 6)$?

Q[6]:

[hint](#) [answer](#) [solution](#)What is the distance from the point $(-5, -1, -9)$ to the xy -plane?

Q[7]:

[hint](#) [answer](#) [solution](#)

A bird sets off from its nest. It flies one kilometre due north, then two kilometres due east, gaining 100 metres of altitude. How far is it from its nest?

Q[8]:

[hint](#) [answer](#) [solution](#)

A bird sets off from its nest on the ground. It flies two kilometres due north, then two kilometres due east, ending up at a point that is 3 km away from its nest. How high above the ground is that point?

Q[9]:

[hint](#) [answer](#) [solution](#)

A giant straight wall rises from the ground, reaching high in the sky, casting a cold shadow as far as you can see. You walk straight out from the base of the wall for 2 km, ash floating in the air, catching in your throat and stinging your eyes. Tired, you sit on the ground to rest, and look around you. In the hazy distance, you see what at first you think must be an illusion: a single tree. It's the only thing standing in this desolate flatness. Curiosity overcomes your fatigue, and you wobble onto blistered feet. (Not your feet—ew. You kick them out of the way.) You turn at a right angle to your previous course, walking 1 km parallel to the looming monolith, and reach the tree. Even at this distance, the wall seems to emit a sinister hum. Except, no — you realize that sound isn't the wall at all. Three metres up the tree, a colony of murder hornets is busily expanding their nest. For the first time today, you smile.

How far are the murder hornets from the wall?

Q[10]:

[hint](#) [answer](#) [solution](#)

The pressure $p(x, y)$ at the point (x, y) is determined by $x^2 - 2px + y^2 = 1$. An *isobar* is a curve with equation $p(x, y) = c$ for some constant c . Sketch several isobars.

Q[11]:

[answer](#) [solution](#)

Show that the set of all points P that are twice as far from $(3, -2, 3)$ as from $(3/2, 1, 0)$ is a sphere. Find its centre and radius.

►► Stage 3

Q[12]:

[hint](#) [answer](#) [solution](#)

Consider any triangle. Pick a coordinate system so that one vertex is at the origin and a second vertex is on the positive x -axis. Call the coordinates of the second vertex $(a, 0)$ and those of the

third vertex (b, c) . Find the circumscribing circle (the circle that goes through all three vertices).

Q[13](*):

[hint](#) [answer](#) [solution](#)

Find an equation for the set of all points $P = (x, y, z)$ such that the distance from P to the point $(0, 0, 1)$ is equal to the distance from P to the plane $z + 1 = 0$.

Sketch the set, and also describe it in words.

14.2▲ Functions of two variables

Exercises

Jump to [HINTS](#), [ANSWERS](#), [SOLUTIONS](#) or [TABLE OF CONTENTS](#).

►► Stage 1

Q[1]:

[hint](#) [answer](#) [solution](#)

Give an example of a function that has all of \mathbb{R}^2 in its domain, and whose range is a single number.

Q[2]:

[hint](#) [answer](#) [solution](#)

Single-variable functions $f(x)$ and $g(x)$ are sketched below. Both have domain $[-1, 1]$.

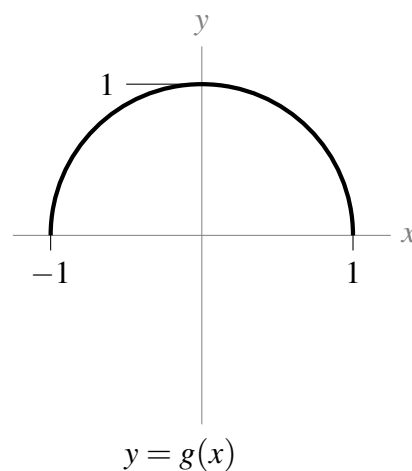
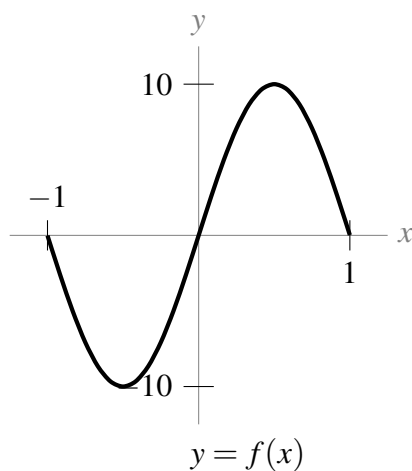

Based on the sketches, find the following.

- The range of $f(x)$,
- the range of $g(x)$,
- the domain of $f(g(x))$, and
- the range of $f(g(x))$.

Q[3]:

[hint](#) [answer](#) [solution](#)

Is the point $(x, y) = (1, 1)$ in the domain of the implicitly defined function

$$z^2y^3 + zx^3 + xy = 1 ?$$

►► Stage 2

Q[4]:

[hint](#) [answer](#) [solution](#)

Find the domain and range of the function

$$f(x,y) = \sqrt{4x^2 + y^2}$$

Q[5]:

[hint](#) [answer](#) [solution](#)

Find the domain and range of the function

$$h(x,y) = \frac{x^2}{1+y^2}$$

Q[6]:

[hint](#) [answer](#) [solution](#)

Find the domain and range of the function

$$k(x,y) = \arcsin(x^2 + y^2)$$

►► Stage 3

Q[7]:

[hint](#) [answer](#) [solution](#)

Find the domain and range of the function

$$g(x,y) = \frac{1}{\log(xy)}$$

Q[8]:

[hint](#) [answer](#) [solution](#)

Find the domain and range of the two-variable function

$$f(x,y) = \frac{x^2}{x^2 + 1}$$

Q[9]:

[hint](#) [answer](#) [solution](#)

Find the domain and range of the function

$$f(x,y) = \frac{x}{x^2 + 1} + \sin y$$

Q[10]:

[hint](#) [answer](#) [solution](#)

If a company spends a dollars on advertisements, and sells the advertised product at p dollars each, then the number of units that will be sold is given as a function $D(a, p)$.

Give a sensible model domain and range.

Q[11]:

[hint](#) [answer](#) [solution](#)

You're using the function

$$f(x,y) = \frac{1}{x^2 + y^2}$$

to model some process. In your model, the only values of the range that make sense are

$$3 \leq f(x,y) \leq 5$$

What is your model domain?

Q[12]:

[hint](#) [answer](#) [solution](#)

You're using the function

$$g(x,y) = 72[x^2 - y]^2 - [x^2 - y]^4$$

to model some process. In your model, the only values of the range that make sense are

$$272 \leq g(x,y) \leq 1175$$

What is the corresponding model domain?

14.3▲ (optional) Sketching surfaces in 3D

Exercises

Jump to [HINTS](#), [ANSWERS](#), [SOLUTIONS](#) or [TABLE OF CONTENTS](#).

►► Stage 1

Q[1](*):

[hint](#) [answer](#) [solution](#)

Match the following equations and expressions with the corresponding pictures.

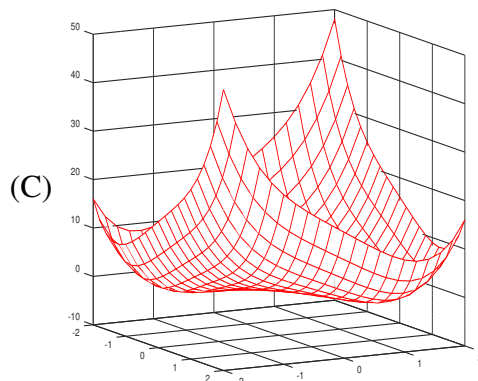
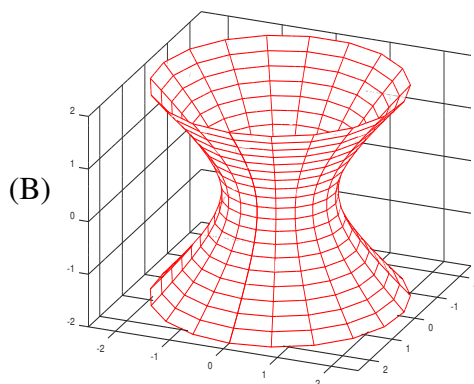
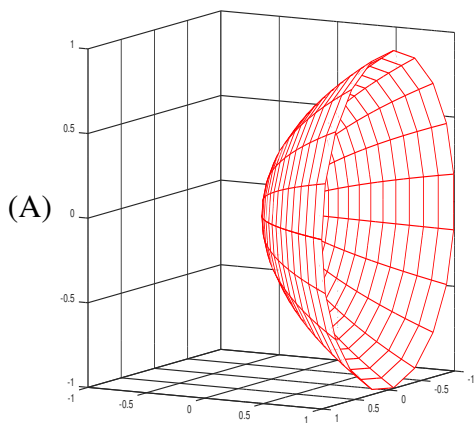

(a) $x^2 + y^2 = z^2 + 1$ (b) $y = x^2 + z^2$ (c) $z = x^4 + y^4 - 4xy$

Q[2]:

[hint](#) [answer](#) [solution](#)

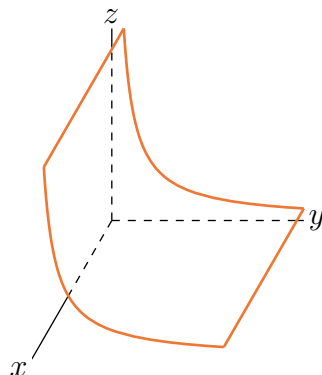
 Sketch a few level curves for the function $f(x,y)$ whose graph $z = f(x,y)$ is sketched below.

►► Stage 2

Q[3]:

[hint](#) [answer](#) [solution](#)

Sketch some of the level curves of

(a) $f(x,y) = x^2 + 2y^2$

(b) $f(x,y) = xy$

(c) $f(x,y) = xe^{-y}$

Q[4](*):

[hint](#) [answer](#) [solution](#)

 Sketch the level curves of $f(x,y) = \frac{2y}{x^2+y^2}$.

Q[5](*):

[hint](#) [answer](#) [solution](#)

A surface is given implicitly by

$$x^2 + y^2 - z^2 + 2z = 0$$

 (a) Sketch several level curves $z = \text{constant}$.

(b) Draw a rough sketch of the surface.

Q[6](*):

[hint](#) [answer](#) [solution](#)

 Sketch the hyperboloid $z^2 = 4x^2 + y^2 - 1$.

Q[7]:

[hint](#) [answer](#) [solution](#)

Sketch the graphs of

(a) $f(x,y) = \sin x$ $0 \leq x \leq 2\pi$, $0 \leq y \leq 1$

(b) $f(x,y) = \sqrt{x^2 + y^2}$

(c) $f(x,y) = |x| + |y|$

Q[8]:

[answer](#) [solution](#)

Sketch and describe the following surfaces.

(a) $4x^2 + y^2 = 16$

(b) $x + y + 2z = 4$

(c) $\frac{y^2}{9} + \frac{z^2}{4} = 1 + \frac{x^2}{16}$

(d) $y^2 = x^2 + z^2$

(e) $\frac{x^2}{9} + \frac{y^2}{12} + \frac{z^2}{9} = 1$

(f) $x^2 + y^2 + z^2 + 4x - by + 9z - b = 0$ where b is a constant.

(g) $\frac{x}{4} = \frac{y^2}{4} + \frac{z^2}{9}$

(h) $z = x^2$

Q[9]:

[hint](#) [answer](#) [solution](#)

Sketch the level curves of the function

$$f(x, y) = \sin(x + y)$$

 for $z = 0$, $z = 1$, and $z = 2$.

►► Stage 3

Q[10]:

[hint](#) [answer](#) [solution](#)

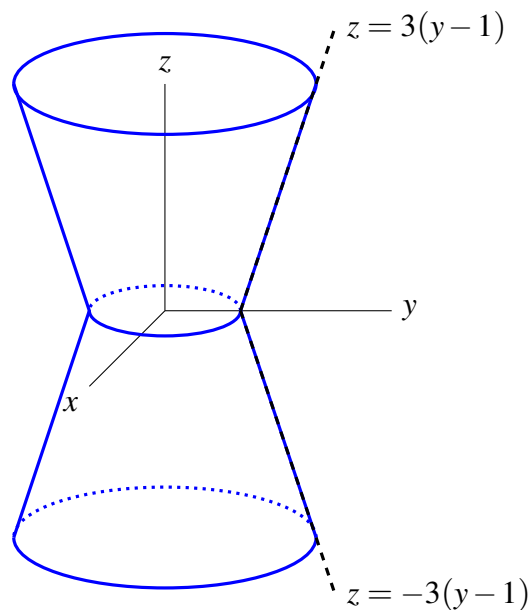
 The surface below has circular level curves, centred along the z -axis. The lines given are the intersection of the surface with the right half of the yz -plane. Give an equation for the surface.

Chapter 15

(FLAVOUR C) PARTIAL DERIVATIVES

15.1▲ Partial derivatives

Exercises

Jump to [HINTS](#), [ANSWERS](#), [SOLUTIONS](#) or [TABLE OF CONTENTS](#).

►► Stage 1

Q[1]:

[hint](#) [answer](#) [solution](#)

You are traversing an undulating landscape. Take the z -axis to be straight up towards the sky, the positive x -axis to be due south, and the positive y -axis to be due east. Then the landscape near you is described by the equation $z = f(x, y)$, with you at the point $(0, 0, f(0, 0))$. The function $f(x, y)$ is differentiable.

Suppose $f_y(0, 0) < 0$. Is it possible that you are at a summit? Explain.

Q[2]:

[hint](#) [answer](#) [solution](#)

The table below gives approximate value of $f(x,y)$ at different values of x and y . (The row gives the value of x , and the column gives the value of y .)

$x \rightarrow$ $y \downarrow$	1.0	1.1	1.2	1.3	1.4	1.5	1.6	1.7	1.8	1.9
1.5	8.2	9.1	10.1	11.2	12.2	13.3	14.4	15.6	16.7	17.9
1.6	8.0	9.0	9.9	10.9	12.0	13.1	14.2	15.3	16.4	17.6
1.7	7.8	8.8	9.7	10.7	11.7	12.8	13.9	15.0	16.1	17.3
1.8	7.6	8.6	9.5	10.5	11.5	12.5	13.6	14.7	15.8	17.0
1.9	7.5	8.4	9.3	10.3	11.3	12.3	13.3	14.4	15.5	16.6
2.0	7.3	8.2	9.1	10.0	11.0	12.0	13.0	14.1	15.2	16.3
2.1	7.1	8.0	8.9	9.8	10.8	11.8	12.8	13.8	14.9	16.0
2.2	7.0	7.8	8.7	9.6	10.5	11.5	12.5	13.5	14.6	15.6
2.3	6.8	7.6	8.5	9.4	10.3	11.2	12.2	13.2	14.2	15.3
2.4	6.6	7.4	8.3	9.1	10.0	11.0	11.9	12.9	13.9	15.0

Use the table to approximate the following partial derivatives.

- $f_y(1.5, 2.4)$
- $f_x(1.7, 1.7)$
- $f_y(1.7, 1.7)$
- $f_x(1.1, 2)$

►► Stage 2

Q[3]:

[answer](#) [solution](#)

Find all first partial derivatives of the following functions and evaluate them at the given point.

- $f(x,y,z) = x^3y^4z^5$ $(0, -1, -1)$
- $w(x,y,z) = \log(1 + e^{xyz})$ $(2, 0, -1)$
- $f(x,y) = \frac{1}{\sqrt{x^2+y^2}}$ $(-3, 4)$

Q[4]:

[hint](#) [answer](#) [solution](#)

Show that the function $z(x,y) = \frac{x+y}{x-y}$ obeys

$$x \frac{\partial z}{\partial x}(x,y) + y \frac{\partial z}{\partial y}(x,y) = 0$$

Q[5](*):

[hint](#) [answer](#) [solution](#)

A surface $z(x, y)$ is defined by $zy - y + x = \log(xyz)$.

- (a) Compute $\frac{\partial z}{\partial x}$, $\frac{\partial z}{\partial y}$ in terms of x, y, z .
 (b) Evaluate $\frac{\partial z}{\partial x}$ and $\frac{\partial z}{\partial y}$ at $(x, y, z) = (-1, -2, 1/2)$.

Q[6](*):

[hint](#) [answer](#) [solution](#)

Find $\frac{\partial U}{\partial T}$ and $\frac{\partial T}{\partial V}$ at $(1, 1, 2, 4)$ if (T, U, V, W) are related by

$$(TU - V)^2 \log(W - UV) = \log 2$$

Q[7](*):

[answer](#) [solution](#)

Suppose that $u = x^2 + yz$, $x = \rho r \cos(\theta)$, $y = \rho r \sin(\theta)$ and $z = \rho r$. Find $\frac{\partial u}{\partial r}$ at the point $(\rho_0, r_0, \theta_0) = (2, 3, \pi/2)$.

Q[8]:

[answer](#) [solution](#)

Use the definition of the derivative to evaluate $f_x(0, 0)$ and $f_y(0, 0)$ for

$$f(x, y) = \begin{cases} \frac{x^2 - 2y^2}{x - y} & \text{if } x \neq y \\ 0 & \text{if } x = y \end{cases}$$

►► Stage 3

Q[9]:

[hint](#) [answer](#) [solution](#)

Let f be any differentiable function of one variable. Define $z(x, y) = f(x^2 + y^2)$. Is the equation

$$y \frac{\partial z}{\partial x}(x, y) - x \frac{\partial z}{\partial y}(x, y) = 0$$

necessarily satisfied?

Q[10]:

[answer](#) [solution](#)

Define the function

$$f(x, y) = \begin{cases} \frac{(x+2y)^2}{x+y} & \text{if } x + y \neq 0 \\ 0 & \text{if } x + y = 0 \end{cases}$$

(a) Evaluate, if possible, $\frac{\partial f}{\partial x}(0, 0)$ and $\frac{\partial f}{\partial y}(0, 0)$.

(b) Is $f(x, y)$ continuous at $(0, 0)$?

Q[11]:

[hint](#) [answer](#) [solution](#)

Consider the cylinder whose base is the radius-1 circle in the xy -plane centred at $(0, 0)$, and which slopes parallel to the line in the yz -plane given by $z = y$.

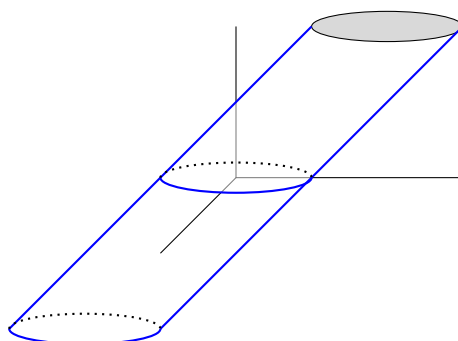

When you stand at the point $(0, -1, 0)$, what is the slope of the surface if you look in the positive y direction? The positive x direction?

Q[12](*):

[hint](#) [answer](#) [solution](#)

Let

$$f(x, y) = \begin{cases} \frac{x^2 y}{x^2 + y^2} & \text{if } (x, y) \neq (0, 0) \\ 0 & \text{if } (x, y) = (0, 0) \end{cases}$$

Compute, directly from the definitions,

(a) $\frac{\partial f}{\partial x}(0, 0)$

(b) $\frac{\partial f}{\partial y}(0, 0)$

(c) $\left. \frac{d}{dt} f(t, t) \right|_{t=0}$

15.2▲ Higher order derivatives

Exercises

Jump to [HINTS](#), [ANSWERS](#), [SOLUTIONS](#) or [TABLE OF CONTENTS](#).

►► Stage 1

Questions 1 – 3 deal with the notation used for higher-order partial derivatives. Notation is only a convention, but conventions usually only catch on if they make some amount of sense. Understanding where the conventions came from makes it easier to remember them.

Q[1]:

[hint](#) [answer](#) [solution](#)

If the partial derivative of the function f with respect to x is written f_x , then why should the partial derivative of f_x with respect to y be written as f_{xy} , rather than as f_{yx} ?

Q[2]:

[hint](#) [answer](#) [solution](#)

If the partial derivative of the function f with respect to x is written $\frac{\partial f}{\partial x}$ or $\frac{\partial f}{\partial x}$, then why should the partial derivative of $\frac{\partial f}{\partial x}$ with respect to y be written as $\frac{\partial^2 f}{\partial y \partial x}$, rather than as $\frac{\partial^2 f}{\partial x \partial y}$?

Q[3]:

[hint](#) [answer](#) [solution](#)

If the first partial derivative of the function f with respect to x is written $\frac{\partial f}{\partial x}$ or $\frac{\partial f}{\partial x}$, then why should the partial derivative of $\frac{\partial f}{\partial x}$ with respect to x be written as $\frac{\partial^2 f}{\partial x^2}$, rather than as $\frac{\partial f^2}{\partial x^2}$?

Q[4]:

[hint](#) [answer](#) [solution](#)

$$f(x, y) = \frac{\tan(xy)}{\ln x}$$

Verify Clairaut's theorem by showing $f_{xy} = f_{yx}$.

►► Stage 2

Q[5]:

[hint](#) [answer](#) [solution](#)

Find the specified partial derivatives.

(a) $f(x, y) = x^2y^3$; $f_{xx}(x, y)$, $f_{xyy}(x, y)$, $f_{yxy}(x, y)$

(b) $f(x, y) = e^{xy^2}$; $f_{xx}(x, y)$, $f_{xy}(x, y)$, $f_{xxy}(x, y)$, $f_{xyy}(x, y)$

(c) $f(u, v, w) = \frac{1}{u + 2v + 3w}$; $\frac{\partial^3 f}{\partial w \partial v \partial u}(u, v, w)$, $\frac{\partial^3 f}{\partial w \partial v \partial u}(3, 2, 1)$

Q[6]:

[hint](#) [answer](#) [solution](#)

Find all second partial derivatives of $f(x, y) = \sqrt{x^2 + 5y^2}$.

Q[7]:

[hint](#) [answer](#) [solution](#)

Find the specified partial derivatives.

(a) $f(x, y, z) = \arctan(e^{\sqrt{xy}})$; $f_{xyz}(x, y, z)$

(b) $f(x, y, z) = \arctan(e^{\sqrt{xy}}) + \arctan(e^{\sqrt{xz}}) + \arctan(e^{\sqrt{yz}})$; $f_{xyz}(x, y, z)$

(c) $f(x, y, z) = \arctan(e^{\sqrt{xyz}})$; $f_{xx}(1, 0, 0)$

►► Stage 3

Q[8]:

[answer](#) [solution](#)

Let $\alpha > 0$ be a constant. Show that $u(x, y, z, t) = \frac{1}{t^{3/2}} e^{-(x^2 + y^2 + z^2)/(4\alpha t)}$ satisfies the heat equation

$$u_t = \alpha(u_{xx} + u_{yy} + u_{zz})$$

for all $t > 0$.

Q[9]:

[hint](#) [answer](#) [solution](#)

The table below gives approximate value of $f(x, y)$ at different values of x and y . (The row gives the value of y , and the column gives the value of x .)

$x \rightarrow$	1.0	1.1	1.2	1.3	1.4	1.5	1.6	1.7	1.8	1.9
$y \downarrow$										
1.5	8.2	9.1	10.1	11.2	12.2	13.3	14.4	15.6	16.7	17.9
1.6	8.0	9.0	9.9	10.9	12.0	13.1	14.2	15.3	16.4	17.6
1.7	7.8	8.8	9.7	10.7	11.7	12.8	13.9	15.0	16.1	17.3
1.8	7.6	8.6	9.5	10.5	11.5	12.5	13.6	14.7	15.8	17.0
1.9	7.5	8.4	9.3	10.3	11.3	12.3	13.3	14.4	15.5	16.6
2.0	7.3	8.2	9.1	10.0	11.0	12.0	13.0	14.1	15.2	16.3
2.1	7.1	8.0	8.9	9.8	10.8	11.8	12.8	13.8	14.9	16.0
2.2	7.0	7.8	8.7	9.6	10.5	11.5	12.5	13.5	14.6	15.6
2.3	6.8	7.6	8.5	9.4	10.3	11.2	12.2	13.2	14.2	15.3
2.4	6.6	7.4	8.3	9.1	10.0	11.0	11.9	12.9	13.9	15.0

Use the table to approximate $f_{xy}(1.8, 2.0)$.

Chapter 16

(FLAVOUR C) OPTIMIZATION OF MULTIVARIABLE FUNCTIONS

16.1▲ Local maximum and minimum values

Exercises

Jump to [HINTS](#), [ANSWERS](#), [SOLUTIONS](#) or [TABLE OF CONTENTS](#).

►► Stage 1

Q[1](*):

[answer](#) [solution](#)

(a) Some level curves of a function $f(x,y)$ are plotted in the xy -plane below.

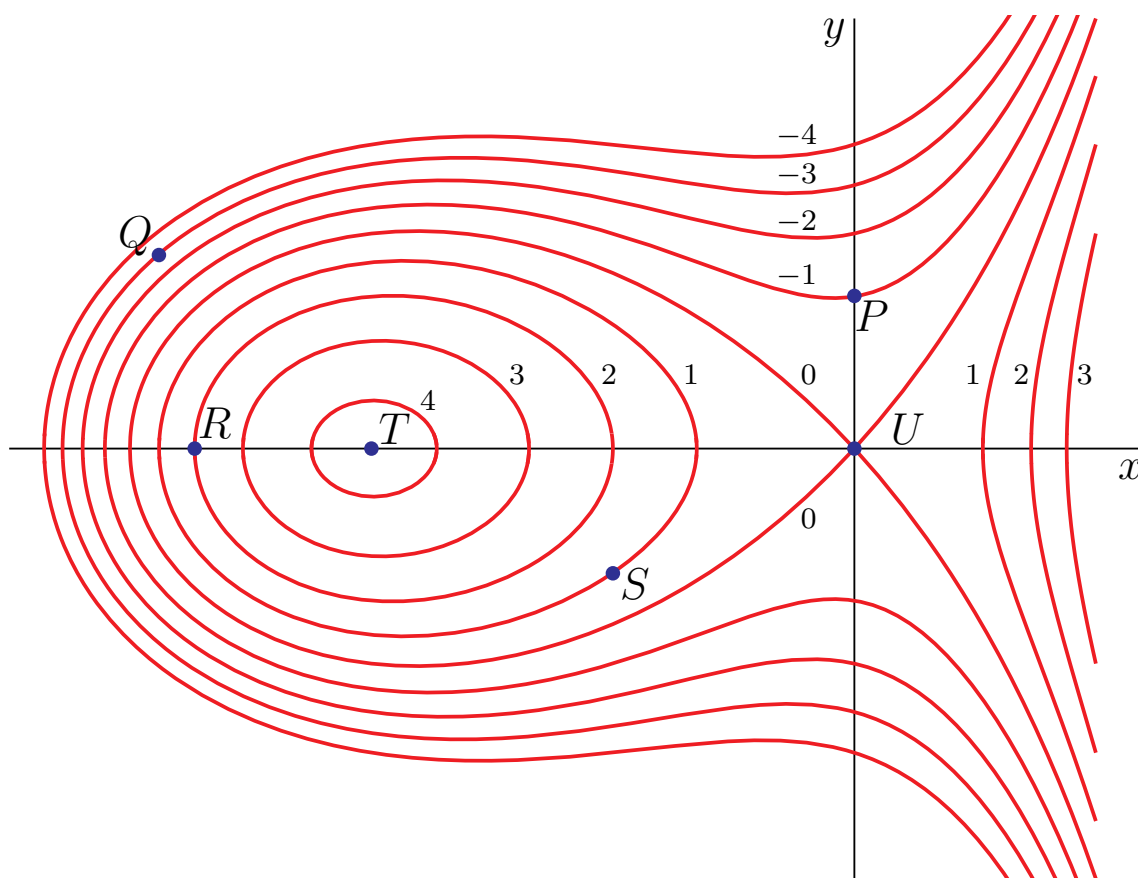

For each of the four statements below, circle the letters of **all** points in the diagram where the situation applies. For example, if the statement were “These points are on the y -axis”, you would circle both P and U , but none of the other letters. You may assume that a local maximum occurs at point T .

- | | |
|------------------------------------------------|-----------|
| (i) ∇f is zero | P R S T U |
| (ii) f has a saddle point | P R S T U |
| (iii) the partial derivative f_y is positive | P R S T U |

(b) The diagram below shows three “ y traces” of a graph $z = F(x, y)$ plotted on xz -axes. (Namely, the intersections of the surface $z = F(x, y)$ with the three planes $y = 1.9$, $y = 2$, and $y = 2.1$.) For each statement below, circle the correct word.

- | | |
|-------------------------------------------------------------|-------------------------------------|
| (i) the first order partial derivative $F_x(1, 2)$ is | positive/negative/zero (circle one) |
| (ii) F has a critical point at $(2, 2)$ | true/false (circle one) |
| (iii) the second order partial derivative $F_{xy}(1, 2)$ is | positive/negative/zero (circle one) |

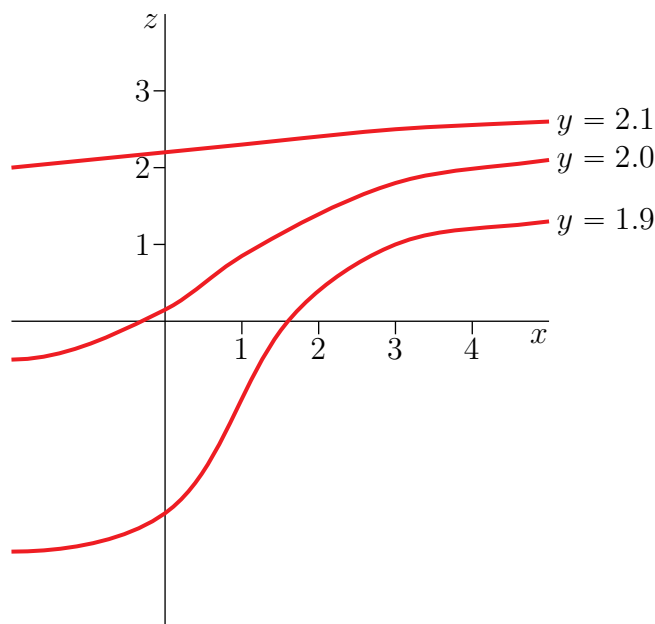
**►► Stage 2**

Q[2](*):

[hint](#) [answer](#) [solution](#)Let $z = f(x, y) = (y^2 - x^2)^2$.

- Make a reasonably accurate sketch of the level curves in the xy -plane of $z = f(x, y)$ for $z = 0, 1$ and 16 . Be sure to show the scales on the coordinate axes.
- Verify that $(0, 0)$ is a critical point for $z = f(x, y)$, and determine from part (a) or directly from the formula for $f(x, y)$ whether $(0, 0)$ is a local minimum, a local maximum or a saddle point.
- Can you use the Second Derivative Test to determine whether the critical point $(0, 0)$ is a local minimum, a local maximum or a saddle point? Give reasons for your answer.

Q[3](*):

[hint](#) [answer](#) [solution](#)Use the Second Derivative Test to find all values of the constant c for which the function $z = x^2 + cx + y^2$ has a saddle point at $(0, 0)$.

Q[4](*):

[hint](#) [answer](#) [solution](#)

Find and classify all critical points of the function

$$f(x, y) = x^3 - y^3 - 2xy + 6.$$

Q[5](*):

[hint](#) [answer](#) [solution](#)Find all critical points for $f(x, y) = x(x^2 + xy + y^2 - 9)$. Also find out which of these points give local maximum values for $f(x, y)$, which give local minimum values, and which give saddle points.

Q[6]:

[hint](#) [answer](#) [solution](#)Find and classify all the critical points of $f(x, y) = x^2 + y^2 + x^2y + 4$.

Q[7](*):

[hint](#) [answer](#) [solution](#)

Find all saddle points, local minima and local maxima of the function

$$f(x, y) = x^3 + x^2 - 2xy + y^2 - x.$$

Q[8](*):

[hint](#) [answer](#) [solution](#)

For the surface

$$z = f(x, y) = x^3 + xy^2 - 3x^2 - 4y^2 + 4$$

Find and classify [as local maxima, local minima, or saddle points] all critical points of $f(x, y)$.

Q[9](*):

[hint](#) [answer](#) [solution](#)

(a) For the function $z = f(x, y) = x^3 + 3xy + 3y^2 - 6x - 3y - 6$. Find and classify as [local maxima, local minima, or saddle points] all critical points of $f(x, y)$.

(b) The images below depict level sets $f(x, y) = c$ of the functions in the list at heights $c = 0, 0.1, 0.2, \dots, 1.9, 2$. Label the pictures with the corresponding function and mark the critical points in each picture. (Note that in some cases, the critical points might not be drawn on the images already. In those cases you should add them to the picture.)

(i) $f(x, y) = (x^2 + y^2 - 1)(x - y) + 1$

(ii) $f(x, y) = y(x + y)(x - y) + 1$

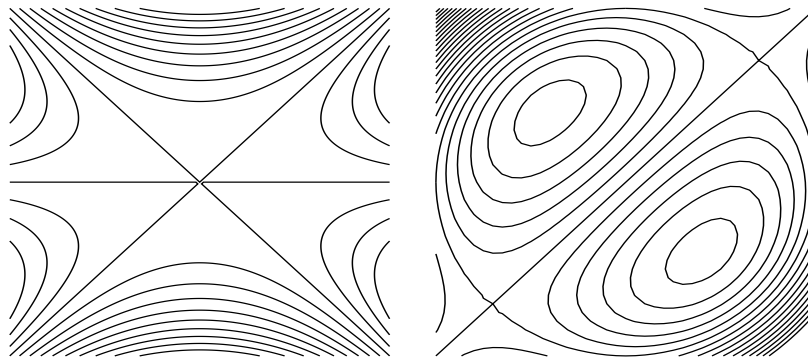

Q[10](*):

[answer](#) [solution](#)

Define the function

$$f(x, y) = x^3 + 3xy + 3y^2 - 6x - 3y - 6$$

Classify all critical points of $f(x, y)$ as local maxima, local minima, or saddle points.

Q[11](*):

[answer](#) [solution](#)Find and classify the critical points of $f(x, y) = 3x^2y + y^3 - 3x^2 - 3y^2 + 4$.

Q[12](*):

[answer](#) [solution](#)Find all critical points of the function $f(x, y) = x^4 + y^4 - 4xy + 2$, and for each determine whether it is a local minimum, maximum or saddle point.

Q[13](*):

[answer](#) [solution](#)

Find all the critical points of the function

$$f(x, y) = x^4 + y^4 - 4xy$$

defined in the xy -plane. Classify each critical point as a local minimum, maximum or saddle point.

Q[14](*):

[hint](#) [answer](#) [solution](#)

Find all the critical points of the function

$$f(x,y) = x^3 + xy^2 - x$$

defined in the xy -plane. Classify each critical point as a local minimum, maximum or saddle point. Explain your reasoning.

Q[15](*):

[answer](#) [solution](#)

Find and classify all critical points of

$$f(x,y) = x^3 - 3xy^2 - 3x^2 - 3y^2$$

►► Stage 3

Q[16](*):

[answer](#) [solution](#)

Consider the function

$$f(x,y) = 3kx^2y + y^3 - 3x^2 - 3y^2 + 4$$

where $k > 0$ is a constant. Find and classify all critical points of $f(x,y)$ as local minima, local maxima, saddle points or points of indeterminate type. Carefully distinguish the cases $k < \frac{1}{2}$, $k = \frac{1}{2}$ and $k > \frac{1}{2}$.

Q[17]:

[hint](#) [answer](#) [solution](#)

An experiment yields data points (x_i, y_i) , $i = 1, 2, \dots, n$. We wish to find the straight line $y = mx + b$ which “best” fits the data. The definition of “best” is “minimizes the root mean square error”, i.e. minimizes $\sum_{i=1}^n (mx_i + b - y_i)^2$. Find m and b .

16.2▲ Absolute minima and maxima

Exercises

Jump to [HINTS](#), [ANSWERS](#), [SOLUTIONS](#) or [TABLE OF CONTENTS](#).

►► Stage 1

Q[1]:

[hint](#) [answer](#) [solution](#)

Suppose you want to find the maximum value of a surface $z = f(x,y)$ on the boundary of the unit circle, $x^2 + y^2 = 1$.

True or false: you should always check the points $(0, \pm 1)$ and $(\pm 1, 0)$, since these are the endpoints of the circle.

Q[2]:

[hint](#) [answer](#) [solution](#)

Find the high and low points of the surface $z = \sqrt{x^2 + y^2}$ with (x,y) varying over the square $|x| \leq 1$, $|y| \leq 1$. Discuss the values of z_x , z_y there. Do not evaluate any derivatives in answering this question.

►► Stage 2

Q[3]:

[hint](#) [answer](#) [solution](#)

Find the maximum and minimum values of $f(x,y) = xy - x^3y^2$ when (x,y) runs over the square $0 \leq x \leq 1, 0 \leq y \leq 1$.

Q[4](*):

[answer](#) [solution](#)

Let $h(x,y) = y(4 - x^2 - y^2)$.

- Find and classify the critical points of $h(x,y)$ as local maxima, local minima or saddle points.
- Find the maximum and minimum values of $h(x,y)$ on the disk $x^2 + y^2 \leq 1$.

Q[5](*):

[hint](#) [answer](#) [solution](#)

Find the absolute maximum and minimum values of the function $f(x,y) = 5 + 2x - x^2 - 4y^2$ on the rectangular region

$$R = \{ (x,y) \mid -1 \leq x \leq 3, -1 \leq y \leq 1 \}$$

Q[6](*):

[answer](#) [solution](#)

Find the minimum of the function $h(x,y) = -4x - 2y + 6$ on the closed bounded domain defined by $x^2 + y^2 \leq 1$.

Q[7](*):

[hint](#) [answer](#) [solution](#)

Let $f(x,y) = xy(x + y - 3)$.

- Find all critical points of f , and classify each one as a local maximum, a local minimum, or saddle point.
- Find the location and value of the absolute maximum and minimum of f on the triangular region $x \geq 0, y \geq 0, x + y \leq 8$.

Q[8](*):

[answer](#) [solution](#)

Consider the function

$$f(x,y) = 2x^3 - 6xy + y^2 + 4y$$

- Find and classify all of the critical points of $f(x,y)$.
- Find the maximum and minimum values of $f(x,y)$ in the triangle with vertices $(1,0)$, $(0,1)$ and $(1,1)$.

Q[9](*):

[hint](#) [answer](#) [solution](#)

Let

$$f(x,y) = xy(x + 2y - 6)$$

- Find every critical point of $f(x,y)$ and classify each one.
- Let D be the region in the plane between the hyperbola $xy = 4$ and the line $x + 2y - 6 = 0$. Find the maximum and minimum values of $f(x,y)$ on D .

Q[10](*):

[hint](#) [answer](#) [solution](#)

A metal plate is in the form of a semi-circular disc bounded by the x -axis and the upper half of $x^2 + y^2 = 4$. The temperature at the point (x, y) is given by

$$T(x, y) = \ln(1 + x^2 + y^2) - y.$$

Find the coldest point on the plate, explaining your steps carefully. (Note: $\ln 2 \approx 0.693$, $\ln 5 \approx 1.609$)

Q[11](*):

[hint](#) [answer](#) [solution](#)

Consider the function $g(x, y) = x^2 - 10y - y^2$.

- Find and classify all critical points of g .
- Find the absolute extrema of g on the bounded region given by

$$x^2 + 4y^2 \leq 16, y \leq 0$$

Q[12]:

[hint](#) [answer](#) [solution](#)

Equal angle bends are made at equal distances from the two ends of a 100 metre long fence, so that the resulting three segment fence can be placed along an existing wall to make an enclosure of trapezoidal shape. What is the largest possible area for such an enclosure?

Q[13]:

[hint](#) [answer](#) [solution](#)

Find the most economical shape of a rectangular box that has a fixed volume V and that has no top.

Q[14](*):

[answer](#) [solution](#)

The temperature $T(x, y)$ at a point of the xy -plane is given by

$$T(x, y) = 20 - 4x^2 - y^2$$

- Find the maximum and minimum values of $T(x, y)$ on the disk D defined by $x^2 + y^2 \leq 4$.
- Suppose the ant is constrained to stay on the curve $y = 2 - x^2$. Where should the ant go if it wants to be as warm as possible?

►► Stage 3

Q[15](*):

[hint](#) [answer](#) [solution](#)

Find the largest and smallest values of x^2y^2z in the part of the plane $2x + y + z = 5$ where $x \geq 0$, $y \geq 0$ and $z \geq 0$. Also find all points where those extreme values occur.

Q[16](*):

[answer](#) [solution](#)

- Show that the function $f(x, y) = 2x + 4y + \frac{1}{xy}$ has exactly one critical point in the first quadrant $x > 0$, $y > 0$, and find its value at that point.
- Use the second derivative test to classify the critical point in part (a).

(c) Explain why the inequality $2x + 4y + \frac{1}{xy} \geq 6$ is valid for all positive real numbers x and y .

Q[17]:

[hint](#) [answer](#) [solution](#)

Let a be a constant real number. Find all points on the surface

$$z = f(x, y) = x^2 + y^2$$

that have minimum distance from the point $(0, 0, a)$.

Q[18]:

[hint](#) [answer](#) [solution](#)

The Scranton branch of a well-known paper company has two sizes of paper for sale - A4 and A3.

Each ream of A4 is sold at \$6; each ream of A3 is sold at \$8. Assume that every ream produced is sold.

Suppose x is the quantity of materials that go into making A4 and y is the quantity of materials that go into making A3. Then the costs involved in turning these materials into paper are $\$1 \cdot x$ for A4 and $\$3 \cdot y$ for A3.

There are different production procedures to produce each paper size. The *production functions* below give the number of reams of paper produced out of a given amount of materials.

$$f(x) = \frac{5}{2}x^{0.8} \quad (\text{for A4})$$

$$g(y) = 10y^{0.6} \quad (\text{for A3})$$

(a) Build the (total) profit equation in terms of x and y . That is, find an equation $\Pi(x, y)$ that gives the total profit (revenue minus cost) over both paper types.

(b) Find the production quantities of both sizes of paper that maximizes profit.

(c) If the branch stops producing A4, what is the optimal production for A3 to maximize profit?

Q[19]:

[hint](#) [answer](#) [solution](#)

Ayan and Pipe each have a lemonade boutique. Making each pitcher of lemonade costs \$1. If Ayan wants to sell q_A lemonades, and Pipe want to sell q_P lemonades, then each pitcher of lemonade will be sold for this price:

$$p(q_A, q_P) = 121 - 2(q_A + q_P)$$

(a) Build the profit equation in terms of q_A and q_P for Ayan. Treating q_P as a constant, find the value of q_A that maximizes Ayan's profit. (Your answer will depend on q_P .)

(b) Build the profit equation in terms of q_A and q_P for Pipe. Treating q_A as a constant, find the value of q_P that maximizes Pipe's profit. (Your answer will depend on q_A .)

(c) Guess, using your intuition, how many pitchers are Ayan and Pipe are going to produce proportional to one another so that both of them maximize their respective profit functions.

(d) Verify your answer for (c) mathematically.

(e) Calculate the profit that each seller generates under these assumptions.

(f) What would be their joint profit if they collaborate? Build a new profit equation where Ayan and Pipe are collaborating and find the optimal joint profit. Compare this to their individual

profit when they are competing and decide whether it would be better for them to collaborate or compete.

(g) Is it better for thirsty consumers when the two sellers collaborate, or when they compete?

16.3▲ Lagrange multipliers

Exercises

Jump to [HINTS](#), [ANSWERS](#), [SOLUTIONS](#) or [TABLE OF CONTENTS](#).

►► Stage 1

Q[1](*): [hint](#) [answer](#) [solution](#)

(a) Does the function $f(x,y) = x^2 + y^2$ have a maximum or a minimum on the curve $xy = 1$? Explain.

(b) Find all maxima and minima of $f(x,y)$ on the curve $xy = 1$.

Q[2]: [hint](#) [answer](#) [solution](#)

Give an example of a continuous surface $f(x,y)$ and a constraint function $g(x,y) = 0$ such that $f(x,y)$ has both a local max and a local min subject to the constraint, but no global max or min.

Q[3]: [hint](#) [answer](#) [solution](#)

Find all absolute extrema of the function $f(x,y) = x \sin y$ subject to the constraint $y = x$.

►► Stage 2

Q[4](*): [hint](#) [answer](#) [solution](#)

Use the method of Lagrange multipliers to find the minimum value of $z = x^2 + y^2$ subject to $x^2y = 1$. At which point or points does the minimum occur?

Q[5](*): [hint](#) [answer](#) [solution](#)

Use the method of Lagrange multipliers to find the maximum and minimum values of

$$f(x,y) = xy$$

subject to the constraint

$$x^2 + 2y^2 = 1.$$

Q[6](*): [hint](#) [answer](#) [solution](#)

Find the maximum and minimum values of $f(x,y) = x^2 + y^2$ subject to the constraint $x^4 + y^4 = 1$.

Q[7]: [hint](#) [answer](#) [solution](#)

Find the absolute extrema of the function $f(x,y) = x^4 + y^4 + \frac{2}{3}y^6$ given the constraint $g(x,y) = x^2 + y^2 = 1$ using the method of Lagrange multipliers.

Q[8]:

[hint](#) [answer](#) [solution](#)

Find the point(s) on the parabola $y = \frac{3}{2} - x^2$ closest to the origin using the method of Lagrange multipliers.

Q[9]:

[hint](#) [answer](#) [solution](#)

What are the largest and smallest values of the product xy , for points (x, y) in the region

$$x^2 - 2xy + 5y^2 \leq 1 ?$$

Q[10](*):

[hint](#) [answer](#) [solution](#)

The temperature in the plane is given by $T(x, y) = e^y(x^2 + y^2)$.

- (a) (i) Give the system of equations that must be solved in order to find the warmest and coolest point on the circle $x^2 + y^2 = 100$ by the method of Lagrange multipliers.
 (ii) Find the warmest and coolest points on the circle by solving that system.
- (b) (i) Give the system of equations that must be solved in order to find the critical points of $T(x, y)$.
 (ii) Find the critical points by solving that system.
- (c) Find the coolest point on the solid disc $x^2 + y^2 \leq 100$.

Q[11]:

[hint](#) [answer](#) [solution](#)

Use the method of Lagrange Multipliers to find the maximum and minimum values of the utility function $U = f(x, y) = 9x^{\frac{1}{3}}y^{\frac{2}{3}}$, subject to the constraint $g(x, y) = 3200x + 200y = 80,000$, where $x \geq 0$ and $y \geq 0$.

►► Stage 3

Q[12](*):

[hint](#) [answer](#) [solution](#)

Suppose that a and b are both greater than zero and let T be the triangle bounded by the line $ax + by = 1$ and the two axes. Use the method of Lagrange multipliers to find the smallest possible area of T if the line $ax + by = 1$ is required to pass through the point $(1, 2)$.

Q[13]:

[hint](#) [answer](#) [solution](#)

Find a and b so that the area πab of an ellipse $\frac{x^2}{a^2} + \frac{y^2}{b^2} = 1$ passing through the point $(1, 2)$ is as small as possible.

(We assume a, b are positive.)

Q[14](*):

[hint](#) [answer](#) [solution](#)

Use the method of Lagrange multipliers to find the radius of the base and the height of a right circular cylinder of maximum volume which can be fit inside the unit sphere $x^2 + y^2 + z^2 = 1$.

Q[15]:

[hint](#) [answer](#) [solution](#)

A rectangular box needs the following properties:

- 72 cubic centimetre volume,

- width twice its length, and
- minimum surface area.

What are the dimensions of the box?

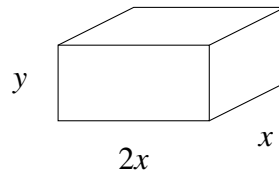

Use Lagrange multipliers to solve.

Q[16]:

[answer](#) [solution](#)

Let $f(x,y)$ have continuous partial derivatives. Consider the problem of finding local minima and maxima of $f(x,y)$ on the curve $xy = 1$.

- Define $g(x,y) = xy - 1$. According to the method of Lagrange multipliers, if (x,y) is a local minimum or maximum of $f(x,y)$ on the curve $xy = 1$, then there is a real number λ such that

$$f_x(x,y) = \lambda g_x(x,y), \quad f_y(x,y) = \lambda g_y(x,y), \quad g(x,y) = 0 \quad (\text{E1})$$

- On the curve $xy = 1$, we have $y = \frac{1}{x}$ and $f(x,y) = f(x, \frac{1}{x})$. Define $F(x) = f(x, \frac{1}{x})$. If $x \neq 0$ is a local minimum or maximum of $F(x)$, we have that

$$F'(x) = 0 \quad (\text{E2})$$

Show that (E1) is equivalent to (E2), in the sense that

there is a λ such that (x,y,λ) obeys (E1)
if and only if
 $x \neq 0$ obeys (E2) and $y = 1/x$.

Q[17]:

[hint](#) [answer](#) [solution](#)

Find all absolute extrema of the function

$$f(x,y) = \sqrt{4x^4 + y^4 - 1}$$

subject to the constraint

$$x^3 + y^3 = 1$$

Q[18]:

[hint](#) [answer](#) [solution](#)

Find all absolute extrema of the function

$$f(x,y) = x + y$$

subject to the constraint

$$x^2 = 1 + y^2$$

Q[19]:

[hint](#) [answer](#) [solution](#)

$$f(x,y) = \frac{x}{1 + (xy)^2}$$

(a) Find all absolute extrema of $f(x,y)$.

(b) Does the line $y = x$ describe a closed curve?

(c) Find all absolute extrema of $f(x,y)$ subject to the constraint $y = x$.

Part II

HINTS TO PROBLEMS

◆————◆

Hints for Exercises 1. — Jump to [TABLE OF CONTENTS](#).

◆————◆

Hints for Exercises 2.1. — Jump to [TABLE OF CONTENTS](#).

H-2: Consider the difference between a limit and a one-sided limit.

H-3: Pay careful attention to which limits are one-sided and which are not.

H-5: The function doesn't have to be continuous.

H-6: See Question 5

H-7: See Question 5

H-8: What is the relationship between the limit and the two one-sided limits?

H-9: What is the relationship between the limit and the two one-sided limits?

H-14: What are the one-sided limits?

H-16: Think about what it means that x does not appear in the function $f(x) = \frac{1}{10}$.

H-17: We only care about what happens really, really close to $x = 3$.

◆————◆

Hints for Exercises 2.1.1. — Jump to [TABLE OF CONTENTS](#).

H-2: Try to make two functions with factors that will cancel.

H-3: Try to make $g(x)$ cancel out.

H-5: See Questions 2, 3, and 4.

H-6: Find the limit of the numerator and denominator separately.

H-7: Break it up into smaller pieces, evaluate the limits of the pieces.

H-8: First find the limit of the “inside” function, $\frac{4x - 2}{x + 2}$.

H-9: Is $\cos(-3)$ zero?

H-10: Expand, then simplify.

H-14: Try the simplest method first.

H-15: Factor the denominator.

H-16: Factor the numerator and the denominator.

H-17: Factor the numerator.

H-18: Simplify first by factoring the numerator.

H-19: The function is a polynomial.

H-20: Multiply both the numerator and the denominator by the conjugate of the numerator, $\sqrt{x^2 + 8} + 3$.

H-21: Multiply both the numerator and the denominator by the conjugate of the numerator, $\sqrt{x + 2} + \sqrt{4 - x}$.

H-22: Multiply both the numerator and the denominator by the conjugate of the numerator, $\sqrt{x - 2} + \sqrt{4 - x}$.

H-23: Consider the factors x^2 and $\cos\left(\frac{3}{x}\right)$ separately.

H-25: Compare to the previous question.

H-26: Factor the numerator.

H-27: Factor the denominator; pay attention to signs.

H-28: First find the limit of the “inside” function.

H-29: Factor; pay attention to signs.

H-30: Look for perfect squares

H-31: Think about what effect changing d has on the function $x^5 - 32x + 15$.

H-32: There’s an easy way.

H-33: What can you do to safely ignore the sine function?

H-34: Factor

H-35: If you’re looking at the hints for this one, it’s probably easier than you think.

H-36: You’ll want to simplify this, since $t = \frac{1}{2}$ is not in the domain of the function. One way to start your simplification is to add the fractions in the numerator by finding a common denominator.

H-37: If you’re not sure how $\frac{|x|}{x}$ behaves, try plugging in a few values of x , like $x = \pm 1$ and $x = \pm 2$.

H-38: Look to Question 37 to see how a function of the form $\frac{|X|}{X}$ behaves.

H-39: Is anything weird happening to this function at $x = 0$?

H-40: Use the limit laws.

H-41: The denominator goes to zero; what must the numerator go to?

H-43: Multiply both the numerator and the denominator by the conjugate of the numerator, $\sqrt{x + 7} + \sqrt{11 - x}$.

H-44: Multiply both the numerator and the denominator by the conjugate of the denominator, $2 + \sqrt{5 - t}$.

H-45: Try plotting points. If you can’t divide by $f(x)$, take a limit.

H-46: There is a close relationship between f and g . Fill in the following table:

x	$f(x)$	$g(x)$	$\frac{f(x)}{g(x)}$
-3			
-2			
-1			
-0			
1			
2			
3			

H-48: When you're evaluating $\lim_{x \rightarrow 0^-} f(x)$, you're only considering values of x that are *less than* 0.

H-49: When you're considering $\lim_{x \rightarrow -4^-} f(x)$, you're only considering values of x that are *less than* -4.

When you're considering $\lim_{x \rightarrow -4^+} f(x)$, think about the domain of the rational function in the top line.

Hints for Exercises 2.1.2. — Jump to [TABLE OF CONTENTS](#).

H-1: It might not look like a traditional polynomial.

H-2: The degree of the polynomial matters.

H-3: What does a negative exponent do?

H-4: You can think about the behaviour of this function by remembering how you first learned to describe exponentiation.

H-5: The exponent will be a negative number.

H-6: What *single* number is the function approaching?

H-7: The highest-order term dominates when x is large.

H-8: Factor the highest power of x out of both the numerator and the denominator. You can factor through square roots (carefully).

H-9: Multiply and divide by the conjugate, $\sqrt{x^2 + 5x} + \sqrt{x^2 - x}$.

H-10: Divide both the numerator and the denominator by the highest power of x that is in the denominator.

Remember that $\sqrt{}$ is defined to be the *positive* square root. Consequently, if $x < 0$, then $\sqrt{x^2}$, which is positive, is *not* the same as x , which is negative.

H-11: Factor out the highest power of the denominator.

H-12: The conjugate of $(\sqrt{x^2 + x} - x)$ is $(\sqrt{x^2 + x} + x)$.

Multiply by $1 = \frac{\sqrt{x^2 + x} + x}{\sqrt{x^2 + x} + x}$ to coax your function into a fraction.

H-13: Divide both the numerator and the denominator by the highest power of x that is in the denominator.

H-14: Divide both the numerator and the denominator by the highest power of x that is in the denominator.

H-15: Divide both the numerator and the denominator by the highest power of x that is in the denominator.

H-16: Divide both the numerator and the denominator by x (which is the largest power of x in the denominator). In the numerator, move the resulting factor of $1/x$ inside the two roots. Be careful about the signs when you do so. Even and odd roots behave differently— see Question 10.

H-17: Divide both the numerator and the denominator by the highest power of x that is in the denominator.

H-18: Divide both the numerator and the denominator by the highest power of x that is in the denominator. It is *not* always true that $\sqrt{x^2} = x$.

H-19: Simplify.

H-20: What is a simpler version of $|x|$ when you know $x < 0$?

H-22: Divide both the numerator and the denominator by the highest power of x that is in the denominator. When is $\sqrt{x} = x$, and when is $\sqrt{x} = -x$?

H-23: Divide both the numerator and the denominator by the highest power of x that is in the denominator. Pay careful attention to signs.

H-24: Multiply and divide the expression by its conjugate, $(\sqrt{n^2 + 5n} + n)$.

H-25: Consider what happens to the function as a becomes very, very small. You shouldn't need to do much calculation.

H-26: Since $x = 3$ is not in the domain of the function, we need to be a little creative. Try simplifying the function.

H-27: This is a bit of a trick question. Consider what happens to a rational function as $x \rightarrow \pm\infty$ in each of these three cases:

- the degree of the numerator is smaller than the degree of the denominator,
- the degree of the numerator is the same as the degree of the denominator, and
- the degree of the numerator is larger than the degree of the denominator.

H-28: We tend to conflate “infinity” with “some really large number.”

Hints for Exercises 2.2. — Jump to [TABLE OF CONTENTS](#).

Hints for Exercises 2.3. — Jump to [TABLE OF CONTENTS](#).

H-1: Try a repeating pattern.

H-2: Compare what is given to you to the definition of continuity.

H-3: Compare what is given to you to the definition of continuity.

-
- H-4: What if the function is discontinuous?
- H-5: What is $h(0)$?
- H-6: Use the definition of continuity.
- H-7: Find the domain: when is the denominator zero?
- H-8: When is the denominator zero? When is the argument of the square root negative?
- H-9: When is the denominator zero? When is the argument of the square root negative?
- H-10: There are infinitely many points where it is *not* continuous.
- H-11: $x = c$ is the important point.
- H-12: The important place is $x = 0$.
- H-13: The important point is $x = c$.
- H-14: The important point is $x = 2c$.

No exercises for Section 3.1. — Jump to [TABLE OF CONTENTS](#)

Hints for Exercises 3.2. — Jump to [TABLE OF CONTENTS](#).

- H-2: You can use (a) to explain (b).
- H-3: Your calculations for slope of the secant lines will all have the same denominators; to save yourself some time, you can focus on the numerators.
- H-4: You can do this by calculating several secant lines. You can also do this by getting out a ruler and trying to draw the tangent line very carefully.
- H-5: There are many possible values for Q and R .
- H-6: A line with slope 0 is horizontal.

Hints for Exercises 3.3. — Jump to [TABLE OF CONTENTS](#).

- H-1: What are the properties of f' when f is a line?
- H-2: Be very careful not to confuse f and f' .
- H-3: Be very careful not to confuse f and f' .
- H-5: The slope has to look “the same” from the left and the right.
- H-6: Use the definition of the derivative, and what you know about limits.
- H-7: Consider continuity.
- H-8: Look at the definition of the derivative. Your answer will be a fraction.

-
- H-9: You need a point (given), and a slope (derivative).
- H-10: You'll need to add some fractions.
- H-11: You don't have to take the limit from the left and right separately—things will cancel nicely.
- H-12: You might have to add fractions
- H-14: Your limit should be easy.
- H-15: add fractions
- H-16: For f to be differentiable at $x = 2$, two things must be true: it must be continuous at $x = 2$, and the derivative from the right must equal the derivative from the left.
- H-17: After you plug in $f(x)$ to the definition of a derivative, you'll want to multiply and divide by the conjugate $\sqrt{1+x+h} + \sqrt{1+x}$.
- H-18: When you're finding the derivative, you'll need to cancel a lot on the numerator, which you can do by expanding the polynomials.
- H-19: You'll need to look at limits from the left and right. The fact that $f(0) = 0$ is useful for your computation. Recall that if $x < 0$ then $\sqrt{x^2} = |x| = -x$.
- H-20: You'll need to look at limits from the left and right. The fact that $f(0) = 0$ is useful for your computation.
- H-21: You'll need to look at limits from the left and right. The fact that $f(0) = 0$ is useful for your computation.
- H-22: You'll need to look at limits from the left and right. The fact that $f(1) = 0$ is useful for your computation.
- H-23: There's lots of room between 0 and $\frac{1}{8}$; see what you can do with it.
- H-24: Set up your usual limit, then split it into two pieces
- H-25: You don't need the definition of the derivative for a line.
- H-26: A generic point on the curve has coordinates (α, α^2) . In terms of α , what is the equation of the tangent line to the curve at the point (α, α^2) ? What does it mean for $(1, -3)$ to be on that line?
- H-27: Remember for a constant n ,

$$\lim_{h \rightarrow 0} h^n = \begin{cases} 0 & n > 0 \\ 1 & n = 0 \\ DNE & n < 0 \end{cases}$$

Hints for Exercises 3.3. — Jump to [TABLE OF CONTENTS](#).

- H-28: Think about units.
- H-35: There are 360 degrees in one rotation.

H-36: $P'(t)$ was discussed in Question 34.

Hints for Exercises 3.4. — Jump to [TABLE OF CONTENTS](#).

H-1: Only one of the curves could possibly represent $y = f(x)$.

Hints for Exercises 3.5. — Jump to [TABLE OF CONTENTS](#).

H-1: Two of the functions are the same.

H-2:

H-3: When can you use the power rule?

H-4: What is the shape of the curve e^{ax} , when a is a positive constant?

H-5: If you know the first derivative, this should be easy.

H-6: Simplify

Hints for Exercises 4.1. — Jump to [TABLE OF CONTENTS](#).

H-1: Look at the Sum rule

H-2: Try an example, like $f(x) = g(x) = x$.

H-3: Simplify

H-4: $g(x) = f(x) + f(x) + f(x)$

H-5: Use linearity and the known derivatives of x^2 and $x^{1/2}$.

H-6: Remember $\frac{d}{dx}\{2^x\} = 2^x \log 2$.

H-7: You have already seen $\frac{d}{dx}\{\sqrt{x}\}$.

H-8: The equation of a line can be determined using a point, and the slope. The derivative of x^3 can be found by writing $x^3 = (x)(x^2)$.

H-9: Be careful to distinguish between speed and velocity.

H-11: How do you take care of that power?

H-12: After you differentiate, factor out e^x .

H-13: Population growth is rate of change of population.

H-15: Interpret it as a derivative that you know how to compute.

H-16: The answer is *not* 10 square metres per second.

H-17: You don't need to know $g(0)$ or $g'(0)$.

H-19: In order to be differentiable, a function should be continuous. To determine the differentiability of the function at $x = 1$, use the definition of the derivative.

H-20: Review Pascal's Triangle.

H-21: Use a similar method to Question 32, Section 4.3.

Hints for Exercises 4.1. — Jump to [TABLE OF CONTENTS](#).

H-22: Check signs

H-23: Read Lemma 4.1.14 carefully.

H-24: Quotient rule

H-25: $e^{2x} = (e^x)^2$

H-26: $e^{a+x} = e^a e^x$

H-27: Figure out where the derivative is positive.

H-28: The acceleration is given by $s''(t)$.

H-29: Product rule will work nicely here. Alternately, review the result of Question 25.

H-30: To find the sign of a product, compare the signs of each factor. The function e^t is always positive.

H-31: Use factorials, as in Example 3.4.2.

H-32: First, factor an x out of the derivative. What's left over looks like a quadratic equation, if you take x^2 to be your variable, instead of x .

H-33: $\frac{1}{t} = t^{-1}$

H-34: First simplify. Don't be confused by the role reversal of x and y : x is just the name of the function $(2y + \frac{1}{y}) \cdot y^3$, which is a function of the variable y . You are to differentiate with respect to y .

H-35: $\sqrt{x} = x^{1/2}$

H-37: You don't need to multiply through.

H-38: You can use the quotient rule.

H-42: There are two pieces of the given function that could cause problems.

H-43: $\sqrt[3]{x} = x^{1/3}$

H-44: Simplify first

H-45: Differentiate a few times until you get zero, remembering that a , b , c , and d are all constants.

H-46: You can re-write this function as a piecewise function, with branches $x \geq 0$ and $x < 0$. To figure out the derivatives at $x = 0$, use the definition of a derivative.

H-47: Let m be the slope of such a tangent line, and let P_1 and P_2 be the points where the tangent line is tangent to the two curves, respectively. There are three equations m fulfills: it has the same

slope as the curves at the given points, and it is the slope of the line passing through the points P_1 and P_2 .

H-48: A line has equation $y = mx + b$, for some constants m and b . What has to be true for $y = mb + x$ to be tangent to the first curve at the point $x = \alpha$, and to the second at the point $x = \beta$?

H-49: Compare this to one of the forms given in the text for the definition of the derivative.

Hints for Exercises 4.2. — Jump to [TABLE OF CONTENTS](#).

H-1: A horizontal tangent line is where the graph appears to “level off.”

H-2: You are going to mark there points on the sine graph where the graph is the steepest, going up.

H-3: $h'(t)$ gives the velocity of the particle, and $h''(t)$ gives its acceleration—the rate the velocity is changing.

H-4: $h'(t)$ gives the velocity of the particle, and $h''(t)$ gives its acceleration—the rate the velocity is changing. Be wary of signs—as in legends, they may be misleading.

H-5: To show that two functions are unequal, you can show that one input results in different outputs.

H-6: You need to memorize the derivatives of sine, cosine, and tangent.

H-7: There are infinitely many values. You need to describe them all.

H-8: Simplify first.

H-9: The identity won't help you.

H-11: Quotient rule

H-14: Use an identity.

H-15: How can you move the negative signs to a location that you can more easily deal with?

H-16: Apply the quotient rule.

H-17: The only spot to worry about is when $x = 0$. For $f(x)$ to be differentiable, it must be continuous, so first find the value of b that makes f continuous at $x = 0$. Then, find the value of a that makes the derivatives from the left and right of $x = 0$ equal to each other.

H-19: Compare this to one of the forms given in the text for the definition of the derivative.

H-20: Compare this to one of the forms given in the text for the definition of the derivative.

H-21: Compare this to one of the forms given in the text for the definition of the derivative.

H-22: $\tan \theta = \frac{\sin \theta}{\cos \theta}$

H-23: In order for a derivative to exist, the function must be continuous, and the derivative from the left must equal the derivative from the right.

H-24: There are infinitely many places where it does *not* exist.

H-31: Recall $|x| = \begin{cases} x & x \geq 0 \\ -x & x < 0 \end{cases}$. To determine whether $h(x)$ is differentiable at $x = 0$, use the definition of the derivative.

H-32: To decide whether the function is differentiable, use the definition of the derivative.

H-33: In this chapter, we learned $\lim_{x \rightarrow 0} \frac{\sin x}{x} = 1$. If you divide the numerator and denominator by x^5 , you can make use of this knowledge.

Hints for Exercises 4.3. — Jump to [TABLE OF CONTENTS](#).

H-1: For parts (a) and (b), remember the definition of a derivative:

$$\frac{dK}{dU} = \lim_{h \rightarrow 0} \frac{K(U+h) - K(U)}{h}.$$

When h is positive, $U+h$ is an increased urchin population; what is the sign of $K(U+h) - K(U)$?

For part (c), use the chain rule!

H-2: Remember that Leibniz notation suggests fractional cancellation.

H-3: If $g(x) = \cos x$ and $h(x) = 5x + 3$, then $f(x) = g(h(x))$. So we apply the chain rule, with “outside” function $\cos x$ and “inside” function $5x + 3$.

H-4: You can expand this into a polynomial, but it’s easier to use the chain rule. If $g(x) = x^5$, and $h(x) = x^2 + 2$, then $f(x) = g(h(x))$.

H-5: You can expand this into a polynomial, but it’s easier to use the chain rule. If $g(k) = k^{17}$, and $h(k) = 4k^4 + 2k^2 + 1$, then $T(k) = g(h(k))$.

H-6: If we define $g(x) = \sqrt{x}$ and $h(x) = \frac{x^2 + 1}{x^2 - 1}$, then $f(x) = g(h(x))$.

To differentiate the square root function: $\frac{d}{dx} \{\sqrt{x}\} = \frac{d}{dx} \{x^{1/2}\} = \frac{1}{2}x^{-1/2} = \frac{1}{2\sqrt{x}}$.

H-7: You’ll need to use the chain rule twice.

H-8: Use the chain rule.

H-9: Use the chain rule.

H-10: Use the chain rule.

H-11: Use the chain rule.

H-12: Recall $\frac{1}{x^2} = x^{-2}$ and $\sqrt{x^2 - 1} = (x^2 - 1)^{1/2}$.

H-14: If we let $g(x) = \sec x$ and $h(x) = e^{2x+7}$, then $f(x) = g(h(x))$, so by the chain rule, $f'(x) = g'(h(x)) \cdot h'(x)$. However, in order to evaluate $h'(x)$, we’ll need to use the chain rule *again*.

H-15: What trig identity can you use to simplify the first factor in the equation?

H-16: Velocity is the derivative of position with respect to time. In this case, the velocity of the particle is given by $s'(t)$.

H-17: The slope of the tangent line is the derivative.
You'll need to use the chain rule twice.

H-18: Start with the product rule, then use the chain rule to differentiate e^{4x} .

H-19: Start with the quotient rule; you'll need the chain rule only to differentiate e^{3x} .

H-20: More than one chain rule needed here.

H-21: More than one chain rule application is needed here.

H-22: More than one chain rule application is needed here.

H-23: More than one chain rule application is needed here.

H-24: What rule do you need, besides chain? Also, remember that $\cos^2 x = [\cos x]^2$.

H-27: The product of two functions is zero exactly when at least one of the functions is zero.

H-28: If $t \geq 1$, then $0 < \frac{1}{t} \leq 1$.

H-29: The notation $\cos^3(5x - 7)$ means $[\cos(5x - 7)]^3$. So, if $g(x) = x^3$ and $h(x) = \cos(5x - 7)$, then $g(h(x)) = [\cos(5x - 7)]^3 = \cos^3(5x - 7)$.

H-30: In Example 4.1.11, we generalized the product rule to three factors:

$$\frac{d}{dx}\{f(x)g(x)h(x)\} = f'(x)g(x)h(x) + f(x)g'(x)h(x) + f(x)g(x)h'(x)$$

This isn't strictly necessary, but it will simplify your computations.

H-31: At time t , the particle is at the point $(x(t), y(t))$, with $x(t) = \cos t$ and $y(t) = \sin t$. Over time, the particle traces out a curve; let's call that curve $y = f(x)$. Then $y(t) = f(x(t))$, so the slope of the curve at the point $(x(t), y(t))$ is $f'(x(t))$. You are to determine the values of t for which $f'(x(t)) = -1$.

H-32: Set $f(x) = e^{x+x^2}$ and $g(x) = 1 + x$. Compare $f(0)$ and $g(0)$, and compare $f'(x)$ and $g'(x)$.

H-33: If $\sin 2x$ and $2 \sin x \cos x$ are the same, then they also have the same derivatives.

H-34: This is a long, nasty problem, but it doesn't use anything you haven't seen before. Be methodical, and break the question into as many parts as you have to. At the end, be proud of yourself for your problem-solving abilities and tenaciousness!

H-35: To sketch the curve, you can start by plotting points. Alternately, consider $x^2 + y$.

Hints for Exercises 4.4. — Jump to [TABLE OF CONTENTS](#).

H-1: Each speaker produces 3dB of noise, so if P is the power of one speaker, $3 = V(P) = 10 \log_{10} \left(\frac{P}{S}\right)$. Use this to find $V(10P)$ and $V(100P)$.

H-2: The question asks you when $A(t) = 2000$. So, solve $2000 = 1000e^{t/20}$ for t .

H-3: What happens when $\cos x$ is a negative number?

H-4: There are two easy ways: use the chain rule, or simplify first.

-
- H-5: There are two easy ways: use the chain rule, or simplify first.
- H-6: Don't be fooled by a common mistake: $\log(x^2 + x)$ is *not* the same as $\log(x^2) + \log x$.
- H-7: Use the base-change formula to convert this to natural logarithm (base e).
- H-9: Use the chain rule.
- H-10: Use the chain rule twice.
- H-11: You'll need to use the chain rule twice.
- H-12: Use the chain rule.
- H-13: Use the chain rule to differentiate.
- H-14: You can differentiate this by using the chain rule several times.
- H-15: Using logarithm rules before you differentiate will make this easier.
- H-16: Using logarithm rules before you differentiate will make this easier.
- H-17: First, differentiate using the chain rule and any other necessary rules. Then, plug in $x = 2$.
- H-18: In the text, you are given the derivative $\frac{d}{dx}a^x$, where a is a constant.
- H-19: You'll need to use logarithmic differentiation. Set $g(x) = \log(f(x))$, and find $g'(x)$. Then, use that to find $f'(x)$. This is the method used in the text to find $\frac{d}{dx}a^x$.
- H-20: Use Question 19 and the base-change formula, $\log_b(a) = \frac{\log a}{\log b}$.
- H-21: To make this easier, use logarithmic differentiation. Set $g(x) = \log(f(x))$, and find $g'(x)$. Then, use that to find $f'(x)$. This is the method used in the text to find $\frac{d}{dx}a^x$, and again in Question 19.
- H-22: To make this easier, use logarithmic differentiation. Set $g(x) = \log(f(x))$, and find $g'(x)$. Then, use that to find $f'(x)$. This is the method used in the text to find $\frac{d}{dx}a^x$, and again in Question 19.
- H-23: It's not going to come out nicely, but there's a better way than blindly applying quotient and product rules, or expanding giant polynomials.
- H-24: You'll need to use logarithmic differentiation. Set $g(x) = \log(f(x))$, and find $g'(x)$. Then, use that to find $f'(x)$. This is the method used in the text to find $\frac{d}{dx}a^x$, and again in Question (19).
- H-25: You'll need to use logarithmic differentiation. Set $g(x) = \log(f(x))$, and find $g'(x)$. Then, use that to find $f'(x)$. This is the method used in the text to find $\frac{d}{dx}a^x$, and again in Question (19).
- H-26: You'll need to use logarithmic differentiation. Set $g(x) = \log(f(x))$, and find $g'(x)$. Then, use that to find $f'(x)$. This is the method used in the text to find $\frac{d}{dx}a^x$, and again in Question (19).
-

H-27: You'll need to use logarithmic differentiation. Differentiate $\log(f(x))$, then solve for $f'(x)$. This is the method used in the text to find $\frac{d}{dx}a^x$.

H-28: Remember to use the chain rule.

H-29: You'll need to use logarithmic differentiation. Differentiate $\log(f(x))$, then solve for $f'(x)$. This is the method used in the text to find $\frac{d}{dx}a^x$.

H-30: You'll need to use logarithmic differentiation. Differentiate $\log(f(x))$, then solve for $f'(x)$. This is the method used in the text to find $\frac{d}{dx}a^x$.

H-31: Evaluate $\frac{d}{dx} \left\{ \log \left([f(x)]^{g(x)} \right) \right\}$.

H-32: Differentiate $y = \log(f(x))$. When is the derivative equal to zero?

Hints for Exercises 4.5. — Jump to [TABLE OF CONTENTS](#).

H-1: Where did the y' come from?

H-2: The three points to look at are $(0, -4)$, $(0, 0)$, and $(0, 4)$. What does the slope of the tangent line look like there?

H-3: A function must pass the vertical line test: one input *cannot* result in two different outputs.

H-4: The problem isn't with any of the algebra.

H-5: Remember that y is a function of x . Use implicit differentiation, then collect all the terms containing $\frac{dy}{dx}$ on one side of the equation to solve for $\frac{dy}{dx}$.

H-6: Differentiate implicitly, then solve for y' .

H-7: Remember that y is a function of x . You can determine explicitly the values of x for which $y(x) = 1$.

H-8: You don't need to solve for y'' in general—only when $x = y = 0$. To do this, you *also* need to find y' at the point $(0, 0)$.

H-10: Plug in $y = 0$ at a strategic point in your work to simplify your computation.

H-11: Use implicit differentiation.

H-13: Plug in $y = 0$ at a strategic point in your work to simplify your computation.

H-14: If the tangent line has slope y' , and it is parallel to $y = x$, then $y' = 1$.

H-15: You don't need to solve for y' in general: only at a single point.

H-16: After you differentiate implicitly, get all the terms containing y' onto one side so you can solve for y' .

H-17: Recall $\frac{d}{dx} \log x = \frac{1}{x}$.

H-18: You don't need to solve for $\frac{dy}{dx}$ for all values of x —only when $y = 0$.

H-20: For (b), you know a point where the curve and tangent line intersect, and you know what the tangent line looks like. What do the derivatives tell you about the shape of the curve?

No exercises for Section 4.6. — Jump to [TABLE OF CONTENTS](#)

Hints for Exercises 4.7. — Jump to [TABLE OF CONTENTS](#).

H-1: Remember that only certain numbers can come out of sine and cosine, but any numbers can go in.

H-2: What is the range of the arccosine function?

H-3: A one-to-one function passes the horizontal line test. To graph the inverse of a function, reflect it across the line $y = x$.

H-4: Your answer will depend on a . The arcsine function alone won't give you every value.

H-5: In order for x to be in the domain of f , you must be able to plug x into both arcsine and arccosecant.

H-6: For the domain of f , remember the domain of arcsine is $[-1, 1]$.

H-7: The domain of $\arccos(t)$ is $[-1, 1]$, but you also have to make sure you aren't dividing by zero.

H-8: $\frac{d}{dx} \{\operatorname{arcsec} x\} = \frac{1}{|x|\sqrt{x^2 - 1}}$, and the domain of $\operatorname{arcsec} x$ is $|x| \geq 1$.

H-9: The domain of $\arctan(x)$ is all real numbers.

H-10: The domain of $\arcsin x$ is $[-1, 1]$, and the domain of \sqrt{x} is $x \geq 0$.

H-11: This occurs only once.

H-12: The answer is a very simple expression.

H-13: chain rule

H-14: Recall $\frac{d}{dx} \{\arctan x\} = \frac{1}{1+x^2} = (1+x^2)^{-1}$.

H-17: You can simplify the expression before you differentiate to remove the trigonometric functions. If $\arctan x = \theta$, then fill in the sides of the triangle below using the definition of arctangent and the Pythagorean theorem:

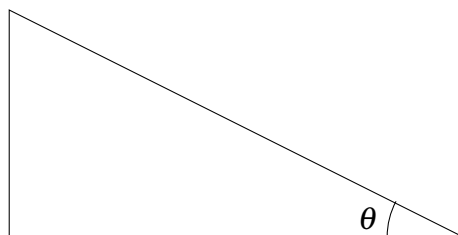

With the sides labeled, you can figure out $\sin(\arctan x) = \sin(\theta)$.

H-18: You can simplify the expression before you differentiate to remove the trigonometric functions. If $\arcsin x = \theta$, then fill in the sides of the triangle below using the definition of arctangent and the Pythagorean theorem:

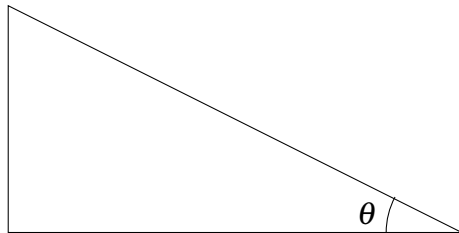

With the sides labeled, you can figure out $\cot(\arcsin x) = \cot(\theta)$.

H-19: What is the slope of the line $y = 2x + 9$?

H-20: Differentiate using the chain rule.

H-21: If $g(y) = f^{-1}(y)$, then $f(g(y)) = f(f^{-1}(y)) = y$. Differentiate this last equality using the chain rule.

H-22: To simplify notation, let $g(y) = f^{-1}(y)$. Simplify and differentiate $g(f(x))$.

H-23: To simplify notation, let $g(y) = f^{-1}(y)$. Simplify and differentiate $g(f(x))$.

H-24: Use logarithmic differentiation.

H-25: Where are those functions defined?

H-26: Compare this to one of the forms given in the text for the definition of the derivative.

H-27: $f^{-1}(7)$ is the number y that satisfies $f(y) = 7$.

H-28: If $f^{-1}(y) = 0$, that means $f(0) = y$. So, we're looking for the number that we plug into f^{-1} to get 0.

H-29: As usual, after you differentiate implicitly, get all the terms containing y' onto one side of the equation, so you can factor out y' .

Hints for Exercises 5. — Jump to [TABLE OF CONTENTS](#).

H-1: If you know P , you can figure out Q .

H-2: Since the point moves along the unit circle, we know that $x^2 + y^2 = 1$, where x and y are functions of time.

H-3: You'll need some implicit differentiation: what should your variable be? Example 5.0.3 shows how to work with percentage rate of change.

H-4: For (b), refer to Example 5.0.3 for percentage rate of change.

H-5: Pay attention to direction, and what it means for the sign (plus/minus) of the velocities of the particles.

-
- H-6: You'll want to think about the difference in the y -coordinates of the two particles.
- H-7: Draw a picture, and be careful about signs.
- H-8: You'll want to think about the *difference* in height of the two snails.
- H-9: The length of the ladder is changing.
- H-10: If a trapezoid has height h and (parallel) bases b_1 and b_2 , then its area is $h \left(\frac{b_1+b_2}{2} \right)$. To figure out how wide the top of the water is when the water is at height h , you can cut the trapezoid up into a rectangle and two triangles, and make use of similar triangles.
- H-11: Be careful with units. One litre is 1000 cm^3 , which is not the same as 10 m^3 .
- H-12: You, the rocket, and the rocket's original position form a right triangle.
- H-13: Your picture should be a triangle.
- H-14: Let θ be the angle between the two hands. Using the Law of Cosines, you can get an expression for D in terms of θ . To find $\frac{d\theta}{dt}$, use what you know about how fast clock hands move.
- H-15: The area in the annulus is the area of the outer circle minus the area of the inner circle.
- H-16: The volume of a sphere with radius R is $\frac{4}{3}\pi r^3$.
- H-17: The area of a triangle is half its base times its height. To find the base, split the triangle into two right triangles.
- H-18: The easiest way to figure out the area of the sector of an annulus (or a circle) is to figure out the area of the entire annulus, then multiply by what proportion of the entire annulus the sector is. For example, if your sector is $\frac{1}{10}$ of the entire annulus, then its area is $\frac{1}{10}$ of the area of the entire annulus.
- H-19: Think about the ways in which this problem is similar to and different from Example 5.0.6 and Question 18.
- H-20: The volume of a cone with height h and radius r is $\frac{1}{3}\pi r^2 h$. Also, one millilitre is the same as one cubic centimetre.
- H-21: If you were to install the buoy, how would you choose the length of rope? For which values of θ do $\sin \theta$ and $\cos \theta$ have different signs? How would those values of θ look on the diagram?
- H-22: At both points of interest, the point is moving along a straight line. From the diagram, you can figure out the equation of that line.
- For the question "How fast is the point moving?" in part (b), remember that the velocity of an object can be found by differentiating (with respect to *time*) the equation that gives the position of the object. The complicating factors in this case are that (1) the position of our object is not given as a function of time, and (2) the position of our object is given in two dimensions, not one.
- H-23: (a) Since the perimeter of the cross section of the bottle does not change, p (the perimeter of the ellipse) is the same as the perimeter of the circle of radius 5.
 (b) The volume of the bottle will be the area of its cross section times its height. This is always the case when you have some two-dimensional shape, and turn it into a three-dimensional object by
-

“pulling” the shape straight up. (For example, you can think of a cylinder as a circle that has been “pulled” straight up. To understand why this formula works, think about what it means to measure the area of a shape in square centimetres, and the volume of an object in cubic centimetres.)

(c) You can use what you know about a and the formula from (a) to find b and $\frac{db}{dt}$. Then use the formula from (b).

H-24: If $A = 0$, you can figure out C and D from the relationship given.

Hints for Exercises 6. — Jump to [TABLE OF CONTENTS](#).

H-1: Try making one function a multiple of the other.

H-2: Try making one function a multiple of the other, but not a *constant* multiple.

H-3: Plugging in $x = 1$ to the numerator and denominator makes both zero. This is exactly one of the indeterminate forms where l’Hôpital’s rule can be directly applied.

H-4: Is this an indeterminate form?

H-5: First, rearrange the expression to a more natural form (without a negative exponent).

H-6: If at first you don’t succeed, try, try again.

H-7: Keep at it!

H-8: Rather than use l’Hôpital, try factoring out x^2 from the numerator and denominator.

H-9: Keep going!

H-11: Try plugging in $x = 0$. Is this an indeterminate form?

H-12: Simplify the trigonometric part first.

H-13: If it is too difficult to take a derivative for l’Hôpital’s Rule, try splitting up the function into smaller chunks and evaluating their limits independently.

H-15: Try manipulating the function to get it into a nicer form

H-17: If the denominator tends to zero, and the limit exists, what must be the limit of the numerator?

H-18: Start with one application of l’Hôpital’s Rule. After that, you need to consider three distinct cases: $k > 2$, $k < 2$, and $k = 2$.

H-19: Percentage error: $100 \left| \frac{\text{exact} - \text{approx}}{\text{exact}} \right|$. Absolute error: $|\text{exact} - \text{approx}|$.

H-20: Try modifying the function from Example 6.3.4.

H-21: $\lim_{x \rightarrow 0} \sqrt{x^2 \sin^2 x} = (\sin^2 x)^{\frac{1}{2}}$; what form is this?

H-22: $\lim_{x \rightarrow 0} \sqrt{x^2 \cos x} = \lim_{x \rightarrow 0} (\cos x)^{\frac{1}{2}}$

H-23: logarithms

H-24: Introduce yet another logarithm.

Hints for Exercises 7.1. — Jump to [TABLE OF CONTENTS](#).

H-1: What happens if $g(x) = x + 3$?

H-2: Use domains and intercepts to distinguish between the functions.

H-3: To find p , the equation $f(0) = 2$ gives you two possible values of p . Consider the domain of $f(x)$ to decide between them.

H-4: Check for horizontal asymptotes by evaluating $\lim_{x \rightarrow \pm\infty} f(x)$, and check for vertical asymptotes by finding any value of x near which $f(x)$ blows up.

H-5: Check for horizontal asymptotes by evaluating $\lim_{x \rightarrow \pm\infty} f(x)$, and check for vertical asymptotes by finding any value of x near which $f(x)$ blows up.

Hints for Exercises 7.2. — Jump to [TABLE OF CONTENTS](#).

H-1: For each of the graphs, consider where the derivative is positive, negative, and zero.

H-2: Where is $f'(x) > 0$?

H-3: Consider the signs of the numerator and the denominator of $f'(x)$.

H-4: Remember $\frac{d}{dx}\{\arctan x\} = \frac{1}{1+x^2}$.

Hints for Exercises 7.3. — Jump to [TABLE OF CONTENTS](#).

H-1: There are two intervals where the function is concave up, and two where it is concave down.

H-2: Try allowing your graph to have horizontal asymptotes. For example, let the function get closer and closer to the x -axis (or another horizontal line) without touching it.

H-3: Consider $f(x) = (x - 3)^4$.

Hints for Exercises 7.4. — Jump to [TABLE OF CONTENTS](#).

H-1: This function is symmetric across the y -axis.

H-2: There are two.

H-3: Since the function is even, you only have to reflect the portion shown across the y -axis to complete the sketch.

H-4: Since the function is odd, to complete the sketch, reflect the portion shown across the y -axis, then the x -axis.

H-5: A function is even if $f(-x) = f(x)$.

H-6: Its period is not 2π .

H-7: Simplify $f(-x)$ to see whether it is the same as $f(x)$, $-f(x)$, or neither.

H-8: Simplify $f(-x)$ to see whether it is the same as $f(x)$, $-f(x)$, or neither.

H-9: Find the smallest value k such that $f(x+k) = f(x)$ for any x in the domain of f .

You may use the fact that the period of $g(X) = \tan X$ is π .

H-10: It is true that $f(x) = f(x+2\pi)$ for every x in the domain of $f(x)$, but the period is not 2π .

No exercises for Section 7.5. — Jump to [TABLE OF CONTENTS](#)

Hints for Exercises 7.6. — Jump to [TABLE OF CONTENTS](#).

H-1: You'll find the intervals of increase and decrease. These will give you a basic outline of the behaviour of the function. Use concavity to refine your picture.

H-2: The local maximum is also a global maximum.

H-3: The sign of the first derivative is determined entirely by the numerator, but the sign of the second derivative depends on both the numerator and the denominator.

H-4: The function is odd.

H-5: The function is continuous at $x = 0$, but its derivative is not.

H-6: Since you aren't asked to find the intervals of concavity exactly, sketch the intervals of increase and decrease, and turn them into a smooth curve. You might not get exactly the intervals of concavity that are given in the solution, but there should be the same number of intervals as the solution, and they should have the same positions relative to the local extrema.

H-7: Use intervals of increase and decrease, concavity, and asymptotes to sketch the curve.

H-8: Although the function exhibits a certain kind of repeating behaviour, it is not periodic.

H-9: The period of this function is 2π . So, it's enough to graph the curve $y = f(x)$ over the interval $[-\pi, \pi]$, because that figure will simply repeat.

Use trigonometric identities to write $f''(x) = -4(4\sin^2 x + \sin x - 2)$. Then you can find where $f''(x) = 0$ by setting $y = \sin x$ and solving $0 = 4y^2 + y - 2$.

H-10: There is one point where the curve is continuous but has a vertical tangent line.

H-11: Use $\lim_{x \rightarrow -\infty} f'(x)$ to determine $\lim_{x \rightarrow -\infty} f(x)$.

H-12: Once you have the graph of a function, reflect it over the line $y = x$ to graph its inverse. Be careful of the fact that $f(x)$ is only defined in this problem for $x \geq 0$.

H-14: For (a), don't be intimidated by the new names: we can graph these functions using the methods learned in this section.

For (b), remember that to define an inverse of a function, we need to restrict the domain of that function to an interval where it is one-to-one. Then to graph the inverse, we can simply reflect the original function over the line $y = x$.

For (c), set $y(x) = \cosh^{-1}(x)$, so $\cosh(y(x)) = x$. The differentiate using the chain rule. To get your final answer in terms of x (instead of y), use the identity $\cosh^2(y) - \sinh^2(y) = 1$.

Hints for Exercises 8.1. — Jump to [TABLE OF CONTENTS](#).

H-1: Estimate $f'(0)$.

H-2: If the graph is discontinuous at a point, it is not differentiable at that point.

H-3: Try making a little bump at $x = 2$, the letting the function get quite large somewhere else.

H-4: Critical points are those values of x for which $f'(x) = 0$.

Singular points are those values of x for which $f(x)$ is not differentiable.

H-5: We're only after local extrema, not global. Let $f(x)$ be our function. If there is some interval around $x = 2$ where nothing is bigger than $f(2)$, then $f(2)$ is a local maximum, whether or not it is a maximum overall.

H-6: By Theorem 8.1.3, if $x = 2$ not a critical point, then it must be a singular point.

H-7: You should be able to figure out the global minima of $f(x)$ in your head.

Remember with absolute values, $|X| = \begin{cases} X & X \geq 0 \\ -X & X < 0 \end{cases}$.

H-8: Review the definitions of critical points and extrema: Definition 8.1.5 and Definition 8.1.2.

Hints for Exercises 8.2. — Jump to [TABLE OF CONTENTS](#).

H-1: One way to avoid a global minimum is to have $\lim_{x \rightarrow \infty} f(x) = -\infty$. Since $f(x)$ keeps getting lower and lower, there is no one value that is the lowest.

H-2: Try allowing the function to approach the x -axis without ever touching it.

H-3: Since the global minimum value occurs at $x = 5$ and $x = -5$, it must be true that $f(5) = f(-5)$.

H-4: Global extrema will either occur at critical points in the interval $(-5, 5)$ or at the endpoints $x = 5, x = -5$.

H-5: You only need to consider critical points that are in the interval $(-4, 0)$.

Hints for Exercises 8.3. — Jump to [TABLE OF CONTENTS](#).

H-1: Factor the derivative.

H-2: Remember to test endpoints.

H-4: One way to decide whether a critical point $x = c$ is a local extremum is to consider the first derivative. For example: if $f'(x)$ is negative for all x just to the left of c , and positive for all x just to the right of c , then $f(x)$ decreases up till c , then increases after c , so $f(x)$ has a local minimum at c .

H-5: One way to decide whether a critical point $x = c$ is a local extremum is to consider the first derivative. For example: if $f'(x)$ is negative for all x just to the left of c , and positive for all x just to the right of c , then $f(x)$ decreases up till c , then increases after c , so $f(x)$ has a local minimum at c .

H-6: Start with a formula for travel time from P to B . You might want to assign a variable to the distance from A where your buggy first reaches the road.

H-7: A box has three dimensions; make variables for them, and write the relations given in the problem in terms of these variables.

H-8: Find a formula for the cost of the base, and another formula for the cost of the other sides. The total cost is the sum of these two formulas.

H-9: The setup is this:

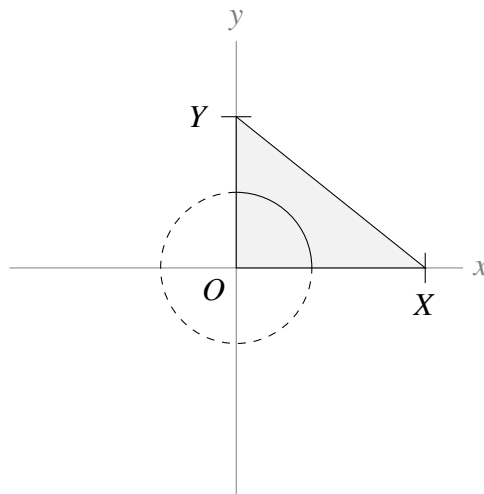

H-10: Put the whole system on xy -axes, so that you can easily describe the pieces using (x,y) -coordinates.

H-11: The surface area consists of two discs and a strip. Find the areas of these pieces.

The volume of a cylinder with radius r and height h is $\pi r^2 h$.

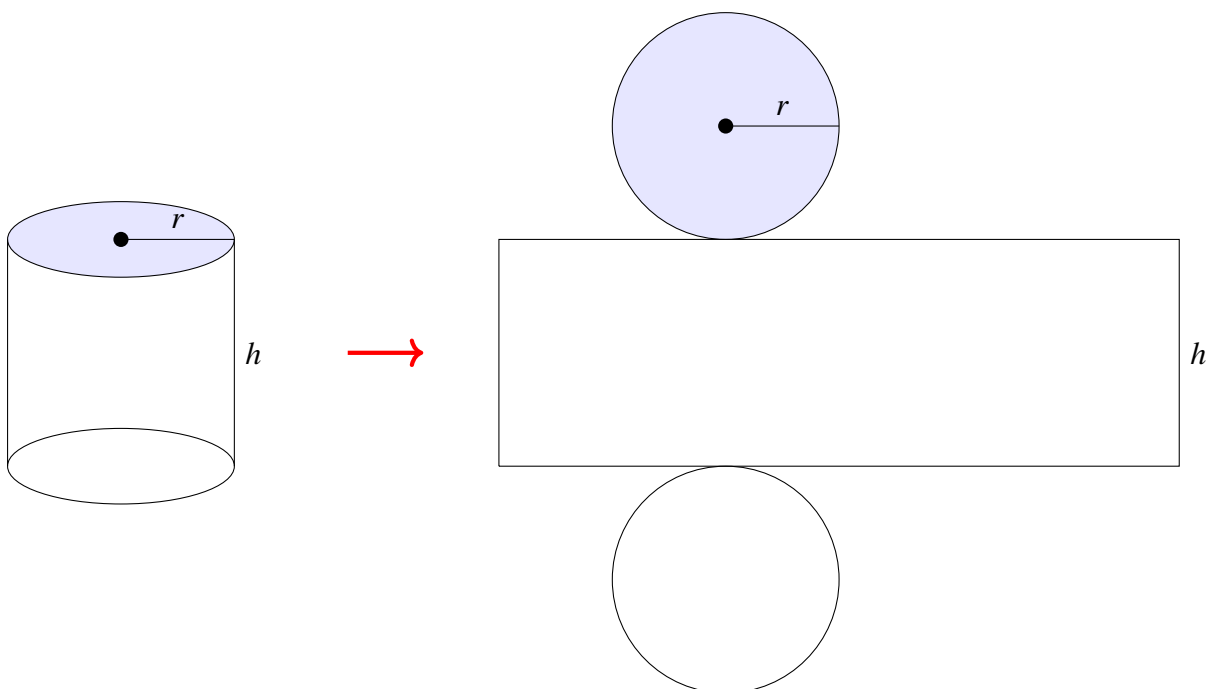

H-12: If the circle has radius r , and the entire window has perimeter P , what is the height of the rectangle?

H-14: Use logarithmic differentiation to find $f'(x)$.

H-15: When you are finding the global extrema of a function, remember to check endpoints as well as critical points.

Hints for Exercises 8.4. — Jump to [TABLE OF CONTENTS](#).

Hints for Exercises 9.1. — Jump to [TABLE OF CONTENTS](#).

H-1: An approximation should be something you can actually figure out—otherwise it’s no use.

H-2: You’ll need some constant a to approximation $\log(0.93) \approx \log(a)$. This a should have two properties: it should be close to 0.93, and you should be able to easily evaluate $\log(a)$.

H-3: You’ll need some constant a to approximate $\arcsin(0.1) \approx \arcsin(a)$. This a should have two properties: it should be close to 0.1, and you should be able to easily evaluate $\arcsin(a)$.

H-4: You’ll need some constant a to approximate $\sqrt{3}\tan(1) \approx \sqrt{3}\tan(a)$. This a should have two properties: it should be close to 1, and you should be able to easily evaluate $\sqrt{3}\tan(a)$.

H-5: We could figure out 10.1^3 exactly, if we wanted, with pen and paper. Since we’re asking for an approximation, we aren’t after perfect accuracy. Rather, we’re after ease of calculation.

Hints for Exercises 9.2. — Jump to [TABLE OF CONTENTS](#).

H-1: The linear approximation $L(x)$ is chosen so that $f(5) = L(5)$ and $f'(5) = L'(5)$.

H-2: The graph of the linear approximation is a line, passing through $(2, f(2))$, with slope $f'(2)$.

H-3: It's an extremely accurate approximation.

H-4: You'll need to centre your approximation about some $x = a$, which should have two properties: you can easily compute $\log(a)$, and a is close to 0.93.

H-5: Approximate the function $f(x) = \sqrt{x}$.

H-6: Approximate the function $f(x) = \sqrt[5]{x}$.

H-7: Approximate the function $f(x) = x^3$.

H-8: One possible choice of $f(x)$ is $f(x) = \sin x$.

H-9: Compare the derivatives.

Hints for Exercises 9.3. — Jump to [TABLE OF CONTENTS](#).

H-1: If $Q(x)$ is the quadratic approximation of f about 3, then $Q(3) = f(3)$, $Q'(3) = f'(3)$, and $Q''(3) = f''(3)$.

H-2: It is a very good approximation.

H-3: Approximate $f(x) = \log x$.

H-4: You'll probably want to centre your approximation about $x = 0$.

H-5: The quadratic approximation of a function $f(x)$ about $x = a$ is

$$f(x) \approx f(a) + f'(a)(x-a) + \frac{1}{2}f''(a)(x-a)^2$$

H-6: One way to go about this is to approximate the function $f(x) = 5 \cdot x^{1/3}$, because then $5^{4/3} = 5 \cdot 5^{1/3} = f(5)$.

H-7: For (c), look for cancellations.

H-8: Compare (c) to (b).

Compare (e) and (f) to (d).

To get an alternating sign, consider powers of (-1) .

H-9: You can evaluate $f(1)$ exactly.

Recall $\frac{d}{dx} \arcsin x = \frac{1}{\sqrt{1-x^2}}$.

H-10: Let $f(x) = e^x$, and use the quadratic approximation of $f(x)$ about $x = 0$ (given in your text, or you can reproduce it) to approximate $f(1)$.

H-11: Be wary of indices: for example $\sum_{n=1}^3 n = \sum_{n=5}^7 (n-4)$.

Hints for Exercises 9.4. — Jump to [TABLE OF CONTENTS](#).

H-1: $T_3''(x)$ and $f''(x)$ agree when $x = 1$.

H-2: The n th degree Taylor polynomial for $f(x)$ about $x = 5$ is

$$T_n(x) = \sum_{k=0}^n \frac{f^{(k)}(5)}{k!} (x-5)^k$$

Match up the terms.

H-3: The fourth-degree Maclaurin polynomial for $f(x)$ is

$$T_4(x) = f(0) + f'(0)x + \frac{1}{2}f''(0)x^2 + \frac{1}{3!}f'''(0)x^3 + \frac{1}{4!}f^{(4)}(0)x^4$$

while the third-degree Maclaurin polynomial for $f(x)$ is

$$T_3(x) = f(0) + f'(0)x + \frac{1}{2}f''(0)x^2 + \frac{1}{3!}f'''(0)x^3$$

H-4: The third-degree Taylor polynomial for $f(x)$ about $x = 1$ is

$$T_3(x) = f(1) + f'(1)(x-1) + \frac{1}{2}f''(1)(x-1)^2 + \frac{1}{3!}f'''(1)(x-1)^3$$

How can you recover $f(1)$, $f'(1)$, $f''(1)$, and $f'''(1)$ from $T_4(x)$?

H-5: Compare the given polynomial to the more standard form of the n th degree Taylor polynomial,

$$\sum_{k=0}^n \frac{1}{k!} f^{(k)}(5)(x-5)^k$$

and notice that the term you want (containing $f^{(10)}(5)$) corresponds to $k = 10$ in the standard form, but is *not* the term corresponding to $k = 10$ in the polynomial given in the question.

H-6: $T_3'''(a) = f'''(a)$

Hints for Exercises 9.5. — Jump to [TABLE OF CONTENTS](#).

H-1: The derivatives of $f(x)$ repeat themselves.

H-2: You are approximating a polynomial with a polynomial.

H-3: Recall $\frac{d}{dx} \{2^x\} = 2^x \log 2$, where $\log 2$ is the constant $\log_e 2$.

H-4: Just keep differentiating—it gets easier!

H-5: Start by differentiating, and finding the pattern for $f^{(k)}(0)$. Remember the chain rule!

H-6: You'll need to differentiate x^x . This is accomplished using logarithmic differentiation, covered in Section 4.4.

H-7: What is $6 \arctan\left(\frac{1}{\sqrt{3}}\right)$?

H-8: After a few derivatives, this will be very similar to Example 9.5.2.

H-9: Treat the even and odd powers separately.

H-10: Compare this to the Maclaurin polynomial for e^x .

H-11: Compare this to the Maclaurin polynomial for cosine.

Hints for Exercises 9.6. — Jump to [TABLE OF CONTENTS](#).

H-1: $R(10) = f(10) - F(10) = -3 - 5$

H-2: Equation 9.6.6 tells us

$$|f(2) - T_3(2)| = \left| \frac{f^{(4)}(c)}{4!} (2-0)^4 \right|$$

for some c strictly between 0 and 2.

H-3: You are approximating a third-degree polynomial with a fifth-degree Taylor polynomial. You should be able to tell how good your approximation will be without a long calculation.

H-4: Draw a picture—it should be clear how the two approximations behave.

H-5: In this case, Equation 9.6.6 tells us that

$$|f(11.5) - T_5(11.5)| = \left| \frac{f^{(6)}(c)}{6!} (11.5 - 11)^6 \right|$$

for some c strictly between 11 and 11.5.

H-6: In this case, Equation 9.6.6 tells us that $|f(0.1) - T_2(0.1)| = \left| \frac{f^{(3)}(c)}{3!} (0.1 - 0)^3 \right|$ for some c strictly between 0 and 0.1.

H-7: In our case, Equation 9.6.6 tells us

$$\left| f\left(-\frac{1}{4}\right) - T_5\left(-\frac{1}{4}\right) \right| = \left| \frac{f^{(6)}(c)}{6!} \left(-\frac{1}{4} - 0\right)^6 \right|$$

for some c between $-\frac{1}{4}$ and 0.

H-8: In this case, Equation 9.6.6 tells us that $|f(30) - T_3(30)| = \left| \frac{f^{(4)}(c)}{4!} (30 - 32)^4 \right|$ for some c strictly between 30 and 32.

H-9: In our case, Equation 9.6.6 tells us

$$|f(0.01) - T_1(0.01)| = \left| \frac{f^{(2)}(c)}{2!} \left(0.01 - \frac{1}{\pi}\right)^2 \right| \text{ for some } c \text{ between } 0.01 \text{ and } \frac{1}{\pi}.$$

H-10: Using Equation 9.6.6, $\left|f\left(\frac{1}{2}\right) - T_2\left(\frac{1}{2}\right)\right| = \left|\frac{f^{(3)}(c)}{3!}\left(\frac{1}{2} - 0\right)^3\right|$ for some c in $\left(0, \frac{1}{2}\right)$.

H-11: It helps to have a formula for $f^{(n)}(x)$. You can figure it out by taking several derivatives and noticing the pattern, but also this has been given previously in the text.

H-12: You can approximate the function $f(x) = x^{\frac{1}{7}}$.

It's a good bit of trivia to know $3^7 = 2187$.

A low-degree Taylor approximation will give you a good enough estimation. If you guess a degree, and take that Taylor polynomial, the error will *probably* be less than 0.001 (but you still need to check).

H-13: Use the 6th-degree Maclaurin approximation for $f(x) = \sin x$.

H-14: For part (c), after you plug in the appropriate values to Equation 9.6.6, simplify the upper and lower bounds for e separately. In particular, for the upper bound, you'll have to solve for e .

Hints for Exercises 10. — Jump to [TABLE OF CONTENTS](#).

H-9: Note $0.4^3 = 0.064$ and $6^3 = 216$.

Hints for Exercises 11. — Jump to [TABLE OF CONTENTS](#).

H-21: If there are S kg of salt in the entire barrel, then 0.4 litres of barrel water contains $S \cdot \frac{0.4}{20}$ kg of salt.

Hints for Exercises 12. — Jump to [TABLE OF CONTENTS](#).

Hints for Exercises 13. — Jump to [TABLE OF CONTENTS](#).

H-7: Use the formula for the volume of a cube, $V = x^3$, for (a).

Hints for Exercises 14.1. — Jump to [TABLE OF CONTENTS](#).

H-1: The fill patterns are only included to distinguish different parts of the diagram.

H-2: Section 14.1 gives the equation for a sphere.

H-3: This is a review question to get you thinking about \mathbb{R}^2 in a way that will help you get used to \mathbb{R}^3 .

H-4: Compare to Question 3. To visualize what's going on, it can help to consider what shapes you'd get if z were a constant.

If you're struggling to visualize \mathbb{R}^3 , section 14.1.1 in the text shows you how to fold a model of its first octant.

H-5: From the text, the distance from the point (x, y, z) to the point (x', y', z') is

$$\sqrt{(x-x')^2 + (y-y')^2 + (z-z')^2}$$

H-6: From the text, the distance from the point (x, y, z) to the xy -plane is $|z|$.

H-7: From the text, the distance from the point (x, y, z) to the point (x', y', z') is

$$\sqrt{(x-x')^2 + (y-y')^2 + (z-z')^2}$$

100 metres is one-tenth of a kilometre.

H-8: From the text, the distance from the point (x, y, z) to the point (x', y', z') is

$$\sqrt{(x-x')^2 + (y-y')^2 + (z-z')^2}$$

Given the distance and the x and y coordinates, you can solve for the z coordinate.

H-9: At which part of the journey are you actually getting farther away from the wall?

H-10: The isobar is a curve of the form $x^2 - 2cx + y^2 = 1$, where c is a constant. These describe circles – figure out what their centres and radii are.

H-12: This centre must be equidistant from the three vertices.

H-13: From the text, the distance from the point (x, y, z) to the point (x', y', z') is

$$\sqrt{(x-x')^2 + (y-y')^2 + (z-z')^2}$$

Also from the text, the distance from the point (x, y, z) to the xy -plane is $|z|$. Use a similar thought process to find the distance from a point (x, y, z) to the plane $z = -1$.

Hints for Exercises 14.2. — Jump to [TABLE OF CONTENTS](#).

H-1: Once you pick the number for the range, you're basically done....

H-2: This is a review of high-school material, since we have functions of only one variable. We want you to think about it to get in the right mindset.

H-3: If you set $x = y = 1$, is there a solution to the equation?

H-4: To find the range, consider all points in the domain with $x = 0$.

H-5: For the range, consider $h(x, 0)$.

H-6: The domain of the function $\arcsin(x)$ is $[-1, 1]$, and its range is $[-\frac{\pi}{2}, \frac{\pi}{2}]$.

H-7: One way of thinking of $xy > 0$ is that x and y must have the same sign (and both be nonzero).

H-8: y doesn't impact the final value of $f(x, y)$, so think of this as a problem from last semester.

What are the maximum and minimum values of the function $f(x) = \frac{x^2}{x^2+1}$? Can you sketch its graph?

H-9: Consider the functions $f_1(x) = \frac{x}{x^2+1}$ and $f_2(y) = \sin y$ separately.

H-10: Do you see any *signs* that might point you in the right direction?

H-11: The domain will look like a ring

H-12: First work with the function

$$h(t) = 72t^2 - t^4$$

Then, think about the implications of $t = x^2 - y$.

Hints for Exercises 14.3. — Jump to [TABLE OF CONTENTS](#).

H-1: Consider the traces. That is, if you set one variable equal to a constant, what will the resulting cross-sections look like?

H-2: Draw in the plane $z = C$ for several values of C .

H-3: Remember when you set $f(x, y)$ equal to a constant, the result is a curve with only x 's and y 's.

H-4: The circle centred at $(0, a)$ with radius r has equation

$$x^2 + (y - a)^2 = r^2$$

Rearranged, this is

$$x^2 + y^2 - (2a)y = r^2 = a^2$$

Use this to describe the level curves of the function given.

H-5: If z is constant, then the entire expression $-z^2 + 2z$ is one big constant.

H-6: For each fixed z , $4x^2 + y^2 = 1 + z^2$ is an ellipse. So the surface consists of a stack of ellipses one on top of the other. The

H-7: Start by determining what convenient traces look like. For (a), the level curves are less instructive at first than are the traces found by setting y equal to a constant.

H-9: To solve (say) $\sin(x + y) = 0$, you get lots of solutions: $x + y = 0$, $x + y = \pi$, $x + y = 2\pi$, etc.

H-10: Since the level curves are circles centred at the origin (in the xy -plane), the equation will have the form $x^2 + y^2 = g(z)$, where $g(z)$ is a function depending only on z .

Hints for Exercises 15.1. — Jump to [TABLE OF CONTENTS](#).

H-1: What happens if you move “backwards,” in the negative y direction?

H-2: Use the definition of the derivative:

$$f_x(x, y) = \lim_{h \rightarrow 0} \frac{f(x+h, y) - f(x, y)}{h} \approx \frac{f(x+0.1, y) - f(x, y)}{0.1}$$

H-4: Just evaluate $x \frac{\partial z}{\partial x}(x, y) + y \frac{\partial z}{\partial y}(x, y)$.

H-5: This is an implicit differentiation question. Implicit differentiation, as you'll recall from first-semester calculus, is more-or-less just an application of the chain rule.

H-6: Differentiate implicitly.

H-9: Just evaluate $y \frac{\partial z}{\partial x}(x, y)$ and $x \frac{\partial z}{\partial y}(x, y)$.

H-11: You can find an equation for the surface, or just look at the diagram.

H-12: For (a) and (b), remember $\frac{\partial f}{\partial x}(x, y) = \lim_{h \rightarrow 0} \frac{f(x+h, y) - f(x, y)}{h}$ and $\frac{\partial f}{\partial y}(x, y) = \lim_{h \rightarrow 0} \frac{f(x, y+h) - f(x, y)}{h}$.

For (c), you're finding the derivative of a function of one variable, say $g(t)$, where

$$g(t) = f(t, t) = \begin{cases} \frac{t^2 t}{t^2 + t^2} & \text{if } t \neq 0 \\ 0 & \text{if } t = 0 \end{cases}$$

Hints for Exercises 15.2. — Jump to [TABLE OF CONTENTS](#).

H-1: Try writing $g = f_x$, and then writing the partial derivative of g with respect to y .

H-2: Try writing $g = \frac{\partial f}{\partial x}$, and then writing the partial derivative of g with respect to y . You aren't asked about the power of the f ; only the order of x and y .

H-3: Look at the displayed equation in the answer to Question 2.

H-4: $\frac{d}{dx}[\tan x] = \sec^2 x$, $\frac{d}{dx}[\sec x] = \sec x \tan x$

H-5: Save yourself time by using Theorem 15.2.5.

H-6: Remember there are *four* second partial derivatives: f_{xx} , f_{xy} , f_{yx} , and f_{yy} .

H-7: (a) This higher order partial derivative can be evaluated extremely efficiently by carefully choosing the order of evaluation of the derivatives.

(b) This higher order partial derivative can be evaluated extremely efficiently by carefully choosing a *different order of evaluation* of the derivatives for each of the three terms.

(c) Set $g(x) = f(x, 0, 0)$. Then $f_{xx}(1, 0, 0) = g''(1)$.

H-9: A similar method as Question 3 in Section 15.1, but iterated.

Hints for Exercises 16.1. — Jump to [TABLE OF CONTENTS](#).

H-2: Write down the equations of specified level curves.

H-3: Remember $a^2 < 1$ means $|a| < 1$, i.e. $-1 < a < 1$.

H-4: Use the Second Derivative Test

H-5: Use the Second Derivative Test

H-6: Use the Second Derivative Test

H-7: Use the second derivative test

H-8: Use the Second Derivative Test

H-9: When you're looking for critical points, remember you need *both* $f_x = 0$ and $f_y = 0$. So if it's hard to solve (say) $f_x = 0$, then first solve $f_y = 0$; then you can narrow your search of $f_x = 0$.

H-14: "Explain your reasoning" is test-speak for "show your work."

H-17: Check Example 16.1.11 in the text.

Hints for Exercises 16.2. — Jump to [TABLE OF CONTENTS](#).

H-1: What is an endpoint of a circle?

H-2: Interpret the height $\sqrt{x^2 + y^2}$ geometrically.

H-3: Check the boundary of the square as well as critical points inside the square.

H-5: There are five places to check: the interior and four boundaries.

H-7: Since the region is a triangle, your boundary will have three separate parts to check.

H-9: There are two boundary lines. You'll want to find their intersections.

H-10: Plugging in the boundaries should be quite easy if you choose your variables wisely

H-11: When you see "classify critical points," think "second derivative test."

H-12: Suppose that the bends are made a distance x from the ends of the fence and that the bends are through an angle θ . Draw a sketch of the enclosure and figure out its area, as a function of x and θ .

H-13: Suppose that the box has side lengths x , y and z .

H-15: If (x, y, z) is on the plane, then you know $z = 5 - 2x - y$. So, you can write x^2y^2z as a function of only x and y by eliminating z .

H-17: The answer will be piecewise, depending on what exactly a is.

H-18: Instead of maximizing the total profit function, maximize the profit functions of each type of paper.

H-19: Profit is (revenue) minus (costs). If Ayan and Pipe work separately, then each seller only sees the cost and revenue from the lemonade that they themselves sold.

To find how much each seller will sell when they are working separately, find out which values of q_A and q_P end up with both individual profit functions being maximized.

To find out how much they'll sell when they're working together, use your assumption from part (c) to make the solving smoother.

Hints for Exercises 16.3. — Jump to [TABLE OF CONTENTS](#).

H-1: Interpret $f(x, y)$ as a distance squared, and sketch $xy = 1$ in the xy -plane. You might also want to review section 16.3.3 in the text.

H-2: The easiest way out is to find a function $z = k(x)$ with local but not absolute extrema, then affix that to the plane $y = 0$.

H-3: Not much calculation is necessary.

H-4: Find all solutions to

$$\begin{aligned}f_x &= \lambda g_x \\f_y &= \lambda g_y \\x^2y &= 1\end{aligned}\tag{E3}$$

H-5: This is a straightforward application of the method of Lagrange multipliers, Theorem 16.3.3 in the text.

H-6: This is a straightforward application of the method of Lagrange multipliers, Theorem 16.3.3 in the text.

H-7: When you set your two equations for λ equal to one another, you should get something that you can easily plug into the constraint function.

H-8: We want to minimize $\sqrt{x^2 + y^2}$; it's easier to minimize $f(x, y) = x^2 + y^2$. The minima will occur at the same point (x, y) .

Note the system has no maximum, since we can keep travelling along the parabola to end up arbitrarily far from the origin.

H-9: To find extrema over a region, we check critical points *and* the boundary.

H-10: You can check your answer from (a) by using a method *other* than Lagrange multipliers.

H-11: Since $x \geq 0$ and $y \geq 0$, our constraint function has endpoints $(x, y) = (0, 400)$ and $(x, y) = (25, 0)$. Absolute extrema will occur at these endpoints or at points that solve the system of Lagrange equations.

H-12: The constraint tells you $a + 2b = 1$. So, your variables are a and b .

H-13: The ellipse $\frac{x^2}{a^2} + \frac{y^2}{b^2} = 1$ passes through the point $(1, 2)$ if and only if $\frac{1}{a^2} + \frac{4}{b^2} = 1$.

H-14: You may choose your coordinate system so the cylinder is oriented vertically along the z -axis. Then you can write the volume of the cylinder as a function of two variables.

H-15: The volume is your constraint function.

H-17: The surface $z = f(x, y)$ is similar to the quadric surface from Example 14.3.2.

H-18: No great amount of computation is needed

H-19: Although $f(x, y)$ is unbounded, and $x = y$ is not a closed curve, there are indeed absolute extrema of $f(x, y)$ subject to $x = y$. To find them, remember last semester's methods for finding extrema of functions of a single variable.

Part III

ANSWERS TO PROBLEMS

Answers to Exercises 1 — Jump to [TABLE OF CONTENTS](#)

A-1:

- (a) $y = x^n$
- (b) $y = x^{-n}$
- (c) $y = x^{1/n}$, n even
- (d) $x^n < x^{1/n} < x^{-n}$
- (e) $y = x^{-n}$

A-3:

- (a) Stretched in y direction by factor A
- (b) Shifted up by a
- (c) Shifted in positive x direction by b

A-8:

- (a) $x = 0, (\frac{3}{2})^{1/3}$
- (b) $x = 0, x = \pm \frac{1}{2}$

A-9: if $m - n$ even: $x = \pm (\frac{A}{B})^{1/(m-n)}, x = 0$;
if $m - n$ odd: $x = (\frac{A}{B})^{1/(m-n)}, x = 0$

A-10:

- (a) $(0,0)$ and $(1,1)$
- (b) $(0,0)$
- (c) $(\frac{\sqrt{7}}{2}, \frac{3}{4})$, $(-\frac{\sqrt{7}}{2}, \frac{3}{4})$, and $(0,-1)$

A-11: $m > -1$

A-12: $x = \left(\frac{B}{A}\right)^{\frac{1}{b-a}}$

A-13:

- (a) $x = 0, -1, 3$
- (b) $x = 1$
- (c) $x = -2, 1/3$

A-14: $x = 1$

A-15: $x = \left(\frac{R}{A}\right)^{\frac{1}{r-a}}$.

A-16: Sketches are not provided.

(a) V

(b) $\frac{V}{S} = \frac{1}{6}a, a > 0$

(c) (i) $a = V^{\frac{1}{3}}$

(ii) $a = (\frac{1}{6}S)^{\frac{1}{2}}$

(iii) $a = 10 \text{ cm}$

(iv) $a = \frac{\sqrt{15}}{3} \text{ cm}$

A-17: Sketches not provided.

(a) V

(b) $\frac{r}{3}$

(c) (i) $r = (\frac{3}{4\pi})^{1/3} V^{1/3}$

(ii) $r = (\frac{1}{4\pi})^{1/2} S^{1/2}$

(iii) $r = \sqrt[3]{\frac{750}{\pi}} \text{ cm}$

(iv) $r = \sqrt{\frac{10}{4\pi}} \text{ cm}$

(v) $S = \frac{36}{\sqrt[3]{\pi}}$

A-18:

(a) $x = I/\gamma$

(b) When $\gamma^2 > 4I\epsilon$, roots are $x = \frac{\gamma \pm \sqrt{\gamma^2 - 4I\epsilon}}{2\epsilon}$; when $\gamma^2 = 4I\epsilon$, root is $x = \frac{\gamma}{2\epsilon}$; otherwise, no roots.

(c) When $\gamma^2 > 4I\epsilon$, both roots are positive. When $\gamma^2 = 4I\epsilon$, root is positive.

A-19:

(a) One way of expressing this relationship is: $P = C \left(\frac{R}{A}\right)^{d/b}$.

(b) One way of expressing this relationship is: $S = 4\pi \left(\frac{3V}{4\pi}\right)^{2/3}$.

A-21: $K = 0.5, a = 2$

Answers to Exercises 2.1 — Jump to [TABLE OF CONTENTS](#)

A-1:

(a) $\lim_{x \rightarrow -2} f(x) = 1$

(b) $\lim_{x \rightarrow 0} f(x) = 0$

(c) $\lim_{x \rightarrow 2} f(x) = 2$

A-2: DNE

A-3:

(a) $\lim_{x \rightarrow -1^-} f(x) = 2$

(b) $\lim_{x \rightarrow -1^+} f(x) = -2$

(c) $\lim_{x \rightarrow -1} f(x) = \text{DNE}$

(d) $\lim_{x \rightarrow -2^+} f(x) = 0$

(e) $\lim_{x \rightarrow 2^-} f(x) = 0$

A-4: Many answers are possible; here is one.

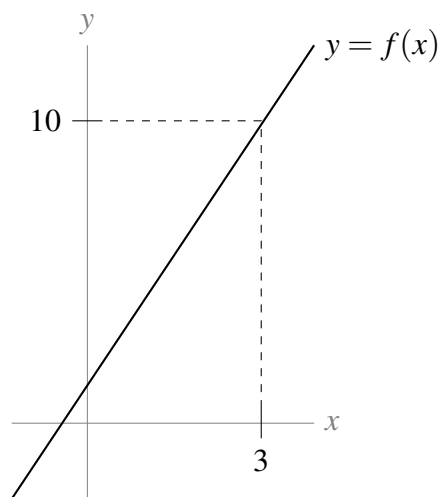

A-5: Many answers are possible; here is one.

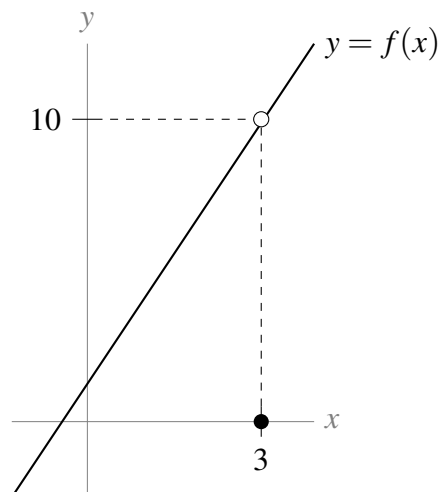

A-6: In general, this is false.

A-7: False

A-8: $\lim_{x \rightarrow -2^-} f(x) = 16$

A-9: Not enough information to say.

A-10: $\lim_{t \rightarrow 0} \sin t = 0$

A-11: $\lim_{x \rightarrow 0^+} \log x = -\infty$

A-12: $\lim_{y \rightarrow 3} y^2 = 9$

A-13: $\lim_{x \rightarrow 0^-} \frac{1}{x} = -\infty$

A-14: $\lim_{x \rightarrow 0} \frac{1}{x} = \text{DNE}$

A-15: $\lim_{x \rightarrow 0} \frac{1}{x^2} = \infty$

A-16: $\lim_{x \rightarrow 3} \frac{1}{10} = \frac{1}{10}$

A-17: 9

Answers to Exercises 2.1.1 — Jump to [TABLE OF CONTENTS](#)

A-1: (a) and (d)

A-2: There are many possible answers; one is $f(x) = 10(x - 3)$, $g(x) = x - 3$.

A-3: There are many possible answers; one is $f(x) = (x - 3)^2$ and $g(x) = x - 3$. Another is $f(x) = 0$ and $g(x) = x - 3$.

A-4: There are many possible answers; one is $f(x) = x - 3$, $g(x) = (x - 3)^3$.

A-5: Any real number; positive infinity; negative infinity; does not exist.

A-6: 0

A-7: 6

A-8: 16

A-9: $4/\cos(3)$

A-10: 2

A-11: $-7/2$

A-12: 3

A-13: $-\frac{3}{2}$

A-14: $\log(2) - 1$

A-15: $\frac{1}{4}$

A-16: $\frac{1}{2}$

A-17: 5

A-18: -6

A-19: -14

A-20: $-\frac{1}{3}$

A-21: $\frac{1}{\sqrt{3}}$

A-22: 1

A-23: 0

A-25: 0

A-26: 5

A-27: $-\infty$

A-28: $\sqrt{\frac{2}{3}}$

A-29: DNE

A-30: ∞

A-31: $x^5 - 32x + 15$

A-32: 0

A-33: 0

A-34: 2

A-35: 0

A-36: $-\frac{32}{9}$

A-37: DNE

A-38: DNE

A-39: $-\frac{9}{2}$

A-40: -4

A-41: $a = \frac{7}{2}$

A-42:

(a) $\lim_{x \rightarrow 0} f(x) = 0$

(b) $\lim_{x \rightarrow 0} g(x) = \text{DNE}$

$$(c) \lim_{x \rightarrow 0} f(x)g(x) = 2$$

$$(d) \lim_{x \rightarrow 0} \frac{f(x)}{g(x)} = 0$$

$$(e) \lim_{x \rightarrow 2} f(x) + g(x) = \frac{9}{2}$$

$$(f) \lim_{x \rightarrow 0} \frac{f(x) + 1}{g(x + 1)} = 1$$

A-43: $\frac{1}{6}$

A-44: 12

A-45:

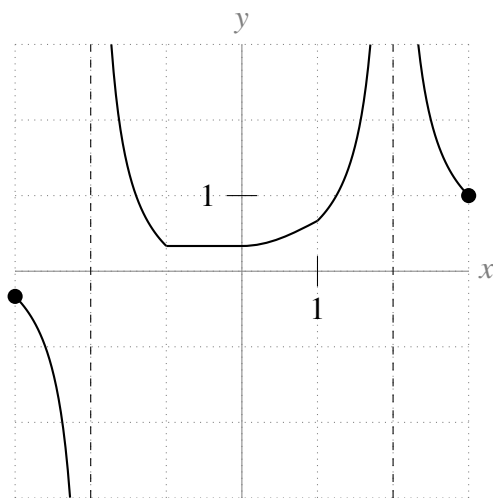

Pictures may vary somewhat; the important points are the values of the function at integer values of x , and the vertical asymptotes.

A-46:

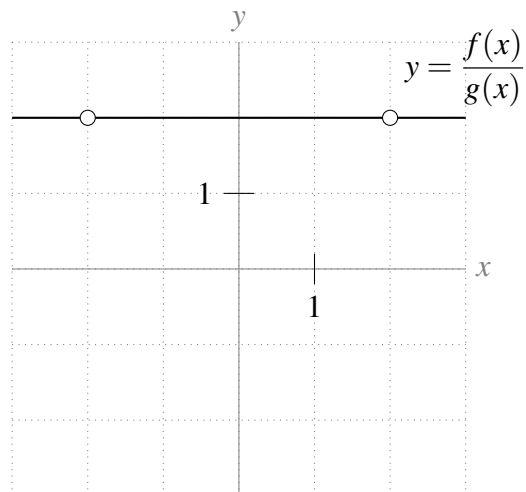

A-47: (a) DNE , DNE (b) 0 (c) No: it is only true when both $\lim_{x \rightarrow a} f(x)$ and $\lim_{x \rightarrow a} g(x)$ exist.

A-48: (a) $\lim_{x \rightarrow 0^-} f(x) = -3$ (b) $\lim_{x \rightarrow 0^+} f(x) = 3$ (c) $\lim_{x \rightarrow 0} f(x) = \text{DNE}$

A-49: (a) $\lim_{x \rightarrow -4^-} f(x) = 0$ (b) $\lim_{x \rightarrow -4^+} f(x) = 0$ (c) $\lim_{x \rightarrow -4} f(x) = 0$

Answers to Exercises 2.1.2 — Jump to [TABLE OF CONTENTS](#)

A-1: There are many answers: any constant polynomial has this property. One answer is $f(x) = 1$.

A-2: There are many answers: any odd-degree polynomial has this property. One answer is $f(x) = x$.

A-3: 0

A-4: ∞

A-5: 0

A-6: DNE

A-7: $-\infty$

A-8: $\sqrt{3}$

A-9: 3

A-10: $-\frac{3}{4}$

A-11: $-\frac{1}{2}$

A-12: $\frac{1}{2}$

A-13: $\frac{5}{3}$

A-14: 0

A-15: $\frac{4}{7}$

A-16: 1

A-17: 0

A-18: -1

A-19: 1

A-20: -1

A-21: $-\frac{3}{2}$

A-22: $-\frac{5}{3}$

A-23: $-\infty$

A-24: $\frac{5}{2}$

A-25: $\lim_{a \rightarrow 0^+} \frac{a^2 - \frac{1}{a}}{a - 1} = \infty$

A-26: $\lim_{x \rightarrow 3} \frac{2x + 8}{\frac{1}{x-3} + \frac{1}{x^2-9}} = 0$

A-27: No such rational function exists.

A-28: This is the amount of the substance that will linger long-term. Since it's nonzero, the substance would be something that would stay in your body. Something like "tattoo ink" is a reasonable answer, while "penicillin" is not.

Answers to Exercises 2.2 — Jump to [TABLE OF CONTENTS](#)

A-1:

- (a) $v \approx K$
- (b) $v = K/2$ – half the maximum rate

A-2:

- (a) $x = 0, 1$
- (b) Both have horizontal asymptotes at $y = 1$.
- (c) y_1
- (d) y_2 (reasoning not provided)

Answers to Exercises 2.3 — Jump to [TABLE OF CONTENTS](#)

A-1: Many answers are possible; the tangent function behaves like this.

A-2: True.

A-3: True.

A-4: In general, false.

A-5: $\lim_{x \rightarrow 0^+} h(x) = 0$

A-6: $k = 0$

A-7: $(-\infty, -1) \cup (-1, 1) \cup (1, +\infty)$

A-8: $(-\infty, -1) \cup (1, +\infty)$

A-9: The function is continuous *except* at $x = \pm\pi, \pm3\pi, \pm5\pi, \dots$

A-10: $x \neq n\pi$, where n is any integer

A-11: ± 2

A-12: $c = 1$

A-13: $-1, 4$

A-14: $c = 1, c = -1$

No exercises for Section 3.1. — Jump to [TABLE OF CONTENTS](#)

Answers to Exercises 3.2 — Jump to [TABLE OF CONTENTS](#)

A-1: If Q is to the left of the y axis, the secant line has positive slope; if Q is to the right of the y axis, the secant line has negative slope.

A-2: (a) closer (b) the tangent line has the larger slope

A-3: $\{(a), (c), (e)\}, \{(b), (f)\}, \{(d)\}$

A-4: Something like 1.5. A reasonable answer would be between 1 and 2.

A-5: There is only one tangent line to $f(x)$ at P (shown in blue), but there are infinitely many choices of Q and R (one possibility shown in red).

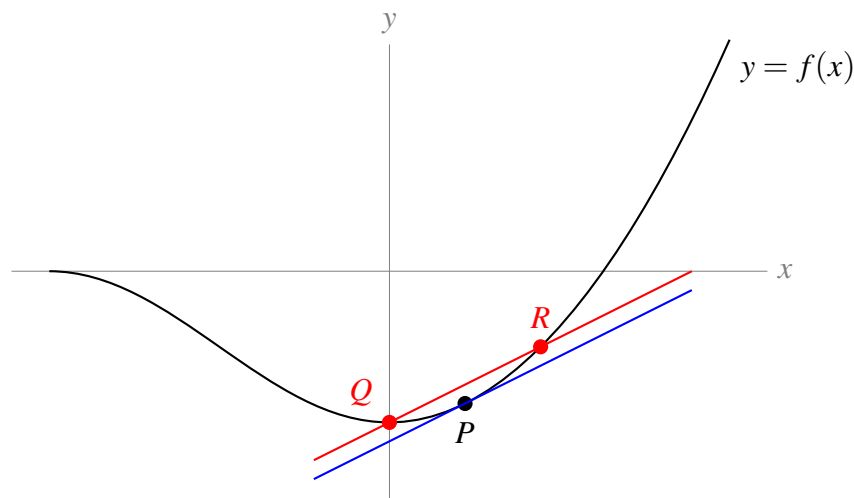

A-6:

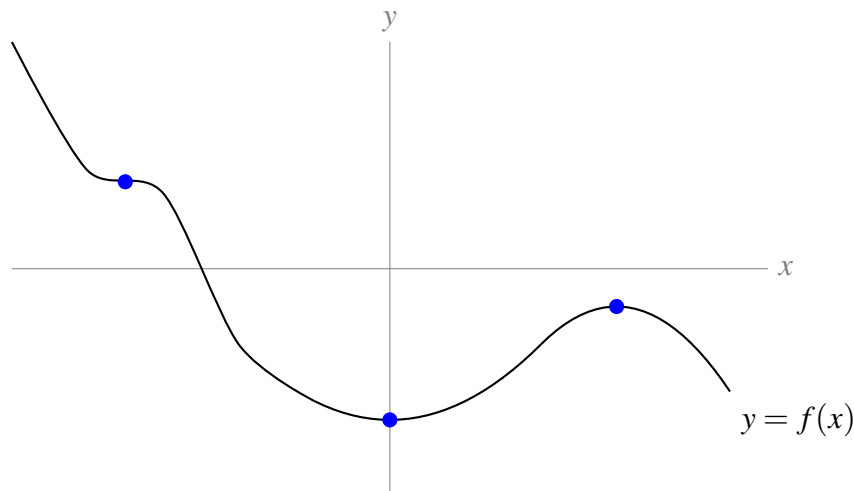

Answers to Exercises 3.3 — Jump to [TABLE OF CONTENTS](#)

A-1: (a), (d)

A-2: (e)

A-3: (b)

A-4: By definition, $f(x) = x^3$ is differentiable at $x = 0$ if the limit

$$\lim_{h \rightarrow 0} \frac{f(h) - f(0)}{h} = \lim_{h \rightarrow 0} \frac{h^3 - 0}{h}$$

exists.

A-5: $x = -1$ and $x = 3$

A-6: True. (Contrast to Question 7.)

A-7: In general, false. (Contrast to Question 6.)

A-8: metres per second

A-9: $y - 6 = 3(x - 1)$, or $y = 3x + 3$

A-10: $\frac{-1}{x^2}$

A-11: By definition

$$f'(0) = \lim_{h \rightarrow 0} \frac{f(h) - f(0)}{h} = \lim_{h \rightarrow 0} \frac{h|h|}{h} = \lim_{h \rightarrow 0} |h| = 0$$

In particular, the limit exists, so the derivative exists (and is equal to zero).

A-12: $\frac{-2}{(x+1)^2}$

A-13: $\frac{-2x}{[x^2+3]^2}$

A-14: 1

A-15: $f'(x) = -\frac{2}{x^3}$

A-16: $a = 4, b = -4$

A-17: $f'(x) = \frac{1}{2\sqrt{1+x}}$ when $x > -1$; $f'(x)$ does not exist when $x \leq -1$.

A-18: $v(t) = 4t^3 - 2t$

A-19: No, it does not.

A-20: No, it does not.

A-21: Yes, it is.

A-22: Yes, it is.

A-23: Many answers are possible; here is one.

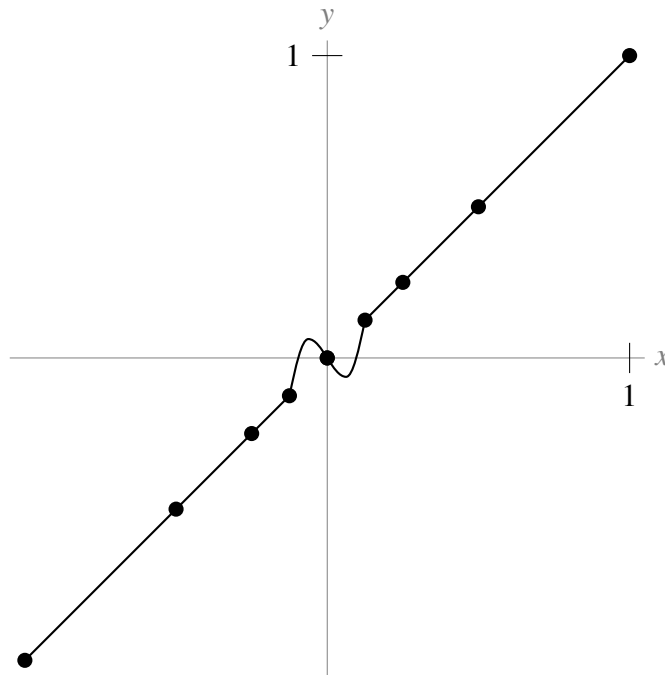

A-24:

$$\begin{aligned}
 p'(x) &= \lim_{h \rightarrow 0} \frac{p(x+h) - p(x)}{h} \\
 &= \lim_{h \rightarrow 0} \frac{f(x+h) + g(x+h) - f(x) - g(x)}{h} \\
 &= \lim_{h \rightarrow 0} \frac{f(x+h) - f(x) + g(x+h) - g(x)}{h} \\
 &= \lim_{h \rightarrow 0} \left[\frac{f(x+h) - f(x)}{h} + \frac{g(x+h) - g(x)}{h} \right] \\
 (*) &= \left[\lim_{h \rightarrow 0} \frac{f(x+h) - f(x)}{h} \right] + \left[\lim_{h \rightarrow 0} \frac{g(x+h) - g(x)}{h} \right] \\
 &= f'(x) + g'(x)
 \end{aligned}$$

At step (*), we use the limit law that $\lim_{x \rightarrow a} [F(x) + G(x)] = \lim_{x \rightarrow a} F(x) + \lim_{x \rightarrow a} G(x)$, as long as $\lim_{x \rightarrow a} F(x)$ and $\lim_{x \rightarrow a} G(x)$ exist. Because the problem states that $f'(x)$ and $g'(x)$ exist, we know that $\lim_{h \rightarrow 0} \frac{f(x+h) - f(x)}{h}$ and $\lim_{h \rightarrow 0} \frac{g(x+h) - g(x)}{h}$ exist, so our work is valid.

A-25: (a) $f'(x) = 2$ and $g'(x) = 1$ (b) $p'(x) = 4x$ (c) no

A-26: $y = 6x - 9$ and $y = -2x - 1$

A-27: $a > 1$

A-28: (a) The average rate of change of the height of the water over the single day starting at $t = 0$, measured in $\frac{\text{m}}{\text{hr}}$.

(b) The instantaneous rate of change of the height of the water at the time $t = 0$.

A-29: Profit per additional widget sold, when t widgets are being sold. This is called the marginal profit per widget, when t widgets are being sold.

A-30: $T'(d)$ measures how quickly the temperature is changing per unit change of depth, measured in degrees per metre. $|T'(d)|$ will probably be largest when d is near zero, unless there are hot springs or other underwater heat sources.

A-31: Calories per additional gram, when there are w grams.

A-32: The acceleration of the object.

A-33: Degrees Celsius temperature change per joule of heat added. (This is closely related to heat capacity and to specific heat — there's a nice explanation of this on Wikipedia.)

A-34: Number of bacteria added per degree. That is: the number of extra bacteria (possibly negative) that will exist in the population by raising the temperature by one degree.

A-35: $360R'(t)$

A-36: If $P'(t)$ is positive, your sample is below the ideal temperature, and if $P'(t)$ is negative, your sample is above the ideal temperature. If $P'(t) = 0$, you don't know whether the sample is exactly at the ideal temperature, or way above or below it with no living bacteria.

Answers to Exercises 3.4 — Jump to [TABLE OF CONTENTS](#)

A-1: (ii)

Answers to Exercises 3.5 — Jump to [TABLE OF CONTENTS](#)

A-1: A-(a) and (d), B-(e), C-(c), D-(b)

A-2: (b), (d), (e)

A-3: False

A-4: increasing

A-5: e^x

A-6: (b) and (d)

Answers to Exercises 4.1 — Jump to [TABLE OF CONTENTS](#)

A-1: True

A-2: False, in general

A-3: True

A-4: If you're creative, you can find lots of ways to differentiate!

Constant multiple: $g'(x) = 3f'(x)$.

Product rule: $g'(x) = \frac{d}{dx}\{3\}f(x) + 3f'(x) = 0f(x) + 3f'(x) = 3f'(x)$.

Sum rule: $g'(x) = \frac{d}{dx}\{f(x) + f(x) + f(x)\} = f'(x) + f'(x) + f'(x) = 3f'(x)$.

Quotient rule: $g'(x) = \frac{d}{dx}\left\{\frac{f(x)}{\frac{1}{3}}\right\} = \frac{\frac{1}{3}f'(x) - f(x)\frac{0}{\frac{1}{3}}}{\left(\frac{1}{3}\right)^2} = \frac{\frac{1}{3}f'(x)}{\frac{1}{9}} = 9\left(\frac{1}{3}\right)f'(x) = 3f'(x)$.

All rules give $g'(x) = 3f'(x)$.

A-5: $f'(x) = 6x + \frac{2}{\sqrt{x}}$

A-6: $f^{(n)} = 2^x(\log 2)^n$

A-7: $-36x + 24\sqrt{x} + \frac{20}{\sqrt{x}} - 45$

A-8: $y - \frac{1}{8} = \frac{3}{4} \cdot \left(x - \frac{1}{2}\right)$, or $y = \frac{3}{4}x - \frac{1}{4}$

A-9: (a) 4 (b) left (c) decreasing

A-10: $\frac{1}{(x+1/2)^2}$, or $\frac{4}{(2x+1)^2}$

A-11: -72

A-12: $g'(x) = [f(x) + f'(x)]e^x$

A-13: $b'(t) - d'(t)$

A-14: $(1,3), (3,27)$

A-15: $\frac{1}{2\sqrt{100180}}$

A-16: $20t + 7$ square metres per second.

A-17: 0

A-18:

First expression, $f(x) = \frac{g(x)}{h(x)}$:

$$f'(x) = \frac{h(x)g'(x) - g(x)h'(x)}{h^2(x)}$$

Second expression, $f(x) = \frac{g(x)}{k(x)} \cdot \frac{k(x)}{h(x)}$:

$$\begin{aligned} f'(x) &= \left(\frac{k(x)g'(x) - g(x)k'(x)}{k^2(x)} \right) \left(\frac{k(x)}{h(x)} \right) + \left(\frac{g(x)}{k(x)} \right) \left(\frac{h(x)k'(x) - k(x)h'(x)}{h^2(x)} \right) \\ &= \frac{k(x)g'(x) - g(x)k'(x)}{k(x)h(x)} + \frac{g(x)h(x)k'(x) - g(x)k(x)h'(x)}{k(x)h^2(x)} \\ &= \frac{h(x)k(x)g'(x) - h(x)g(x)k'(x)}{k(x)h^2(x)} + \frac{g(x)h(x)k'(x) - g(x)k(x)h'(x)}{k(x)h^2(x)} \\ &= \frac{h(x)k(x)g'(x) - h(x)g(x)k'(x) + g(x)h(x)k'(x) - g(x)k(x)h'(x)}{k(x)h^2(x)} \\ &= \frac{h(x)k(x)g'(x) - g(x)k(x)h'(x)}{k(x)h^2(x)} \\ &= \frac{h(x)g'(x) - g(x)h'(x)}{h^2(x)} \end{aligned}$$

and this is exactly what we got from differentiating the first expression.

A-19: $a = b = \frac{e}{2}$

A-20: (a) $g''(x) = [f(x) + 2f'(x) + f''(x)]e^x$

(b) $g'''(x) = [f(x) + 3f'(x) + 3f''(x) + f'''(x)]e^x$

(c) $g^{(4)}(x) = [f(x) + 4f'(x) + 6f''(x) + 4f'''(x) + f^{(4)}(x)]e^x$

A-21: (a) $f'(x) = (1 + 2x)e^{x+x^2}$ $f''(x) = (4x^2 + 4x + 3)e^{x+x^2}$ $h'(x) = 1 + 3x$ $h''(x) = 3$

(b) $f(0) = h(0) = 1$; $f'(0) = h'(0) = 1$; $f''(0) = h''(0) = 3$

(c) f and h “start at the same place,” since $f(0) = h(0)$. Also $f'(0) = h'(0)$, and

$f''(x) = (4x^2 + 4x + 3)e^{x+x^2} > 3e^{x+x^2} > 3 = h''(x)$ when $x > 0$. Since $f'(0) = h'(0)$, and since f' grows faster than h' for positive x , we conclude $f'(x) > h'(x)$ for all positive x . Now we can conclude that (since $f(0) = h(0)$ and f grows faster than h when $x > 0$) also $f(x) > h(x)$ for all positive x .

Answers to Exercises 4.1 — Jump to [TABLE OF CONTENTS](#)

A-22: In the quotient rule, there is a minus, not a plus. Also, $2(x+1) + 2x$ is not the same as $2(x+1)$.

The correct version is:

$$\begin{aligned} f(x) &= \frac{2x}{x+1} \\ f'(x) &= \frac{2(x+1) - 2x}{(x+1)^2} \\ &= \frac{2}{(x+1)^2} \end{aligned}$$

A-23: False

A-24: $\frac{(x-1)e^x}{2x^2}$

A-25: $2e^{2x}$

A-26: e^{a+x}

A-27: $x > -1$

A-28: 0

A-29: $2e^{2x}$

A-30: When t is in the interval $(-2, 0)$.

A-31: $\frac{3}{15!}$

A-32: $4x(x^2 + 2)(x^2 + 3)$

A-33: $12t^3 + 15t^2 + \frac{1}{t^2}$

A-34: $x'(y) = 8y^3 + 2y$

A-35: $T'(x) = \frac{(x^2 + 3) \left(\frac{1}{2\sqrt{x}} \right) - (\sqrt{x} + 1)(2x)}{(x^2 + 3)^2}$

A-36: $\frac{21 - 4x - 7x^2}{(x^2 + 3)^2}$

A-37: 7

A-38: $\frac{3x^4 + 30x^3 - 2x - 5}{(x^2 + 5x)^2}$

A-39: $\frac{-3x^2 + 12x + 5}{(2 - x)^2}$

A-40: $\frac{-22x}{(3x^2 + 5)^2}$

A-41: $\frac{4x^3 + 12x^2 - 1}{(x + 2)^2}$

A-42: The derivative of the function is

$$\frac{(1 - x^2) \cdot \frac{1}{2\sqrt{x}} - \sqrt{x} \cdot (-2x)}{(1 - x^2)^2} = \frac{(1 - x^2) - 2x \cdot (-2x)}{2\sqrt{x}(1 - x^2)^2}$$

The derivative is undefined if either $x < 0$ or $x = 0, \pm 1$ (since the square-root is undefined for $x < 0$ and the denominator is zero when $x = 0, 1, -1$). Putting this together — the derivative exists for $x > 0, x \neq 1$.

A-43: $\left(\frac{3}{5}x^{-\frac{4}{5}} + 5x^{-\frac{2}{3}} \right) (3x^2 + 8x - 5) + (3\sqrt[5]{x} + 15\sqrt[3]{x} + 8) (6x + 8)$

A-44: $f'(x) = (2x + 5)(x^{-1/2} + x^{-2/3}) + (x^2 + 5x + 1) \left(\frac{-1}{2}x^{-3/2} - \frac{2}{3}x^{-5/3} \right)$

A-45: $n = 4$

A-46: (a) In order to make $f(x)$ a little more tractable, let's change the format. Since

$$|x| = \begin{cases} x & x \geq 0 \\ -x & x < 0 \end{cases}, \text{ then:}$$

$$f(x) = \begin{cases} -x^2 & x < 0 \\ x^2 & x \geq 0. \end{cases}$$

Now, we turn to the definition of the derivative to figure out whether $f'(0)$ exists.

$$f'(0) = \lim_{h \rightarrow 0} \frac{f(0+h) - f(0)}{h} = \lim_{h \rightarrow 0} \frac{f(h) - 0}{h} = \lim_{h \rightarrow 0} \frac{f(h)}{h} \quad \text{if it exists.}$$

Since f looks different to the left and right of 0, in order to evaluate this limit, we look at the corresponding one-sided limits. Note that when h approaches 0 from the right, $h > 0$ so $f(h) = h^2$. By contrast, when h approaches 0 from the left, $h < 0$ so $f(h) = -h^2$.

$$\begin{aligned} \lim_{h \rightarrow 0^+} \frac{f(h)}{h} &= \lim_{h \rightarrow 0^+} \frac{h^2}{h} = \lim_{h \rightarrow 0^+} h = 0 \\ \lim_{h \rightarrow 0^-} \frac{f(h)}{h} &= \lim_{h \rightarrow 0^-} \frac{-h^2}{h} = \lim_{h \rightarrow 0^-} -h = 0 \end{aligned}$$

Since both one-sided limits exist and are equal to 0,

$$\lim_{h \rightarrow 0} \frac{f(0+h) - f(0)}{h} = 0$$

and so f is differentiable at $x = 0$ and $f'(0) = 0$.

(b) From (a), $f'(0) = 0$ and

$$f(x) = \begin{cases} -x^2 & x < 0 \\ x^2 & x \geq 0. \end{cases}$$

So,

$$f'(x) = \begin{cases} -2x & x < 0 \\ 2x & x \geq 0. \end{cases}$$

Then, we know the second derivative of f everywhere except at $x = 0$:

$$f''(x) = \begin{cases} -2 & x < 0 \\ ? & x = 0 \\ 2 & x > 0. \end{cases}$$

So, whenever $x \neq 0$, $f''(x)$ exists. To investigate the differentiability of $f'(x)$ when $x = 0$, again we turn to the definition of a derivative. If

$$\lim_{h \rightarrow 0} \frac{f'(0+h) - f'(0)}{h}$$

exists, then $f''(0)$ exists.

$$\lim_{h \rightarrow 0} \frac{f'(0+h) - f'(0)}{h} = \lim_{h \rightarrow 0} \frac{f'(h) - 0}{h} = \lim_{h \rightarrow 0} \frac{f'(h)}{h}$$

Since $f(h)$ behaves differently when h is greater than or less than zero, we look at the one-sided limits.

$$\begin{aligned} \lim_{h \rightarrow 0^+} \frac{f'(h)}{h} &= \lim_{h \rightarrow 0^+} \frac{2h}{h} = 2 \\ \lim_{h \rightarrow 0^-} \frac{f'(h)}{h} &= \lim_{h \rightarrow 0^-} \frac{-2h}{h} = -2 \end{aligned}$$

Since the one-sided limits do not agree,

$$\lim_{h \rightarrow 0} \frac{f'(0+h) - f'(0)}{h} = DNE$$

So, $f''(0)$ does not exist. Now we have a complete picture of $f''(x)$:

$$f''(x) = \begin{cases} -2 & x < 0 \\ DNE & x = 0 \\ 2 & x > 0. \end{cases}$$

A-47: $y = x - \frac{1}{4}$

A-48:

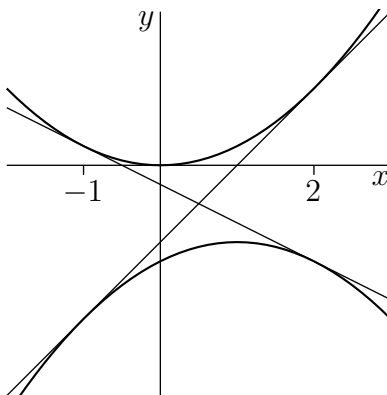

$y = 4x - 4$ and $y = -2x - 1$

A-49: $2015 \cdot 2^{2014}$

Answers to Exercises 4.2 — Jump to [TABLE OF CONTENTS](#)

A-1:

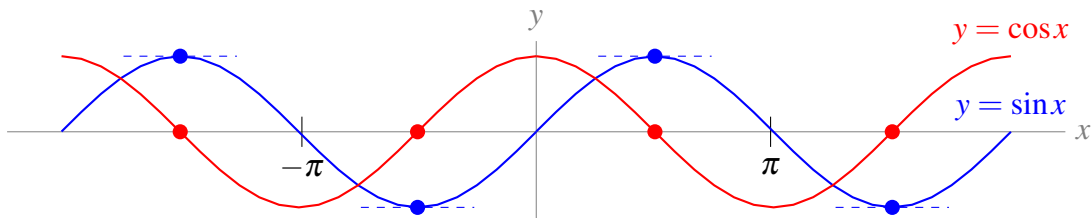

The graph $f(x) = \sin x$ has horizontal tangent lines precisely at those points where $\cos x = 0$.

A-2:

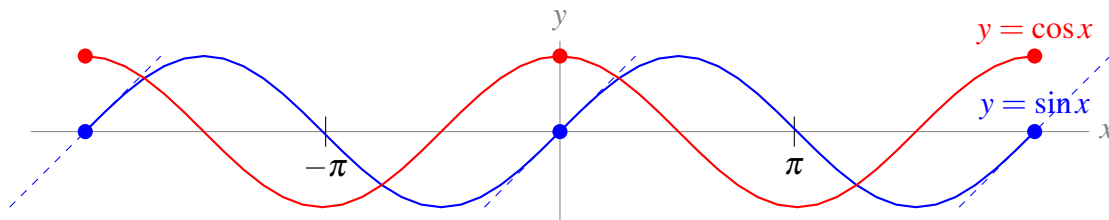

The graph $f(x) = \sin x$ has maximum slope at those points where $\cos x$ has a maximum. That is, where $\cos x = 1$.

A-3: speeding up

A-4: slower

A-5: (a) true (b) true (c) false

A-6: $f'(x) = \cos x - \sin x + \sec^2 x$

A-7: $x = \frac{\pi}{4} + \pi n$, for any integer n .

A-8: 0

A-9: $f'(x) = 2(\cos^2 x - \sin^2 x)$

A-10: $f'(x) = e^x(\cot x - \csc^2 x)$

A-11: $f'(x) = \frac{2 + 3 \sec x + 2 \sin x - 2 \tan x \sec x + 3 \sin x \tan x}{(\cos x + \tan x)^2}$

A-12: $f'(x) = \frac{5 \sec x \tan x - 5 \sec x - 1}{e^x}$

A-13: $f'(x) = (e^x + \cot x)(30x^5 + \csc x \cot x) + (e^x - \csc^2 x)(5x^6 - \csc x)$

A-14: $-\sin(\theta)$

A-15: $f'(x) = -\cos x - \sin x$

A-16: $\left(\frac{\cos \theta + \sin \theta}{\cos \theta - \sin \theta}\right)^2 + 1$

A-17: $a = 0, b = 1$.

A-18: $y - \pi = 1 \cdot (x - \pi/2)$

A-19: $-\sin(2015)$

A-20: $-\sqrt{3}/2$

A-21: -1

A-22:

$$\tan \theta = \frac{\sin \theta}{\cos \theta}$$

So, using the quotient rule,

$$\begin{aligned}\frac{d}{d\theta}\{\tan\theta\} &= \frac{\cos\theta\cos\theta - \sin\theta(-\sin\theta)}{\cos^2\theta} = \frac{\cos^2\theta + \sin^2\theta}{\cos^2\theta} \\ &= \left(\frac{1}{\cos\theta}\right)^2 = \sec^2\theta\end{aligned}$$

A-23: $a = -\frac{2}{3}, b = 2$

A-24: All values of x except $x = \frac{\pi}{2} + n\pi$, for any integer n .

A-25: The function is differentiable whenever $x^2 + x - 6 \neq 0$ since the derivative equals

$$\frac{10\cos(x) \cdot (x^2 + x - 6) - 10\sin(x) \cdot (2x + 1)}{(x^2 + x - 6)^2},$$

which is well-defined unless $x^2 + x - 6 = 0$. We solve $x^2 + x - 6 = (x - 2)(x + 3) = 0$, and get $x = 2$ and $x = -3$. So, the function is differentiable for all real values x except for $x = 2$ and for $x = -3$.

A-26: The function is differentiable whenever $\sin(x) \neq 0$ since the derivative equals

$$\frac{\sin(x) \cdot (2x + 6) - \cos(x) \cdot (x^2 + 6x + 5)}{(\sin x)^2},$$

which is well-defined unless $\sin x = 0$. This happens when x is an integer multiple of π . So, the function is differentiable for all real values x except $x = n\pi$, where n is any integer.

A-27: $y - 1 = 2 \cdot (x - \pi/4)$

A-28: $y = 2x + 2$

A-29: $x = \frac{3\pi}{4} + n\pi$ for any integer n .

A-31: $h'(x) = \begin{cases} \cos x & x > 0 \\ -\cos x & x < 0 \end{cases}$ It exists for all $x \neq 0$.

A-32: iii

A-33: 2

Answers to Exercises 4.3 — Jump to [TABLE OF CONTENTS](#)

A-1: (a) $\frac{dK}{dU}$ is negative (b) $\frac{dU}{dO}$ is negative (c) $\frac{dK}{dO}$ is positive

A-2: negative

A-3: $-5\sin(5x + 3)$

A-4: $10x(x^2 + 2)^4$

A-5: $17(4k^4 + 2k^2 + 1)^{16} \cdot (16k^3 + 4k)$

A-6: $\frac{-2x}{(x^2-1)\sqrt{x^4-1}}$

A-7: $-e^{\cos(x^2)} \cdot \sin(x^2) \cdot 2x$

A-8: -4

A-9: $[\cos x - x \sin x] e^{x \cos(x)}$

A-10: $[2x - \sin x] e^{x^2 + \cos(x)}$

A-11: $\frac{3}{2\sqrt{x-1}\sqrt{x+2}^3}$

A-12: $f'(x) = -\frac{2}{x^3} + \frac{x}{\sqrt{x^2-1}}$ is defined for x in $(-\infty, 1) \cup (1, \infty)$.

A-13: $f'(x) = \frac{(1+x^2)(5 \cos 5x) - (\sin 5x)(2x)}{(1+x^2)^2}$

A-14: $2e^{2x+7} \sec(e^{2x+7}) \tan(e^{2x+7})$

A-15: $y = 1$

A-16: $t = \frac{2}{3}$ and $t = 4$

A-17: $2e \sec^2(e)$

A-18: $y' = 4e^{4x} \tan x + e^{4x} \sec^2 x$

A-19: $\frac{3}{(1+e^3)^2}$

A-20: $2 \sin(x) \cdot \cos(x) \cdot e^{\sin^2(x)}$

A-21: $\cos(e^{5x}) \cdot e^{5x} \cdot 5$

A-22: $-e^{\cos(x^2)} \cdot \sin(x^2) \cdot 2x$

A-23: $y' = -\sin(x^2 + \sqrt{x^2+1}) \left(2x + \frac{x}{\sqrt{x^2+1}} \right)$

A-24: $y' = 2x \cos^2 x - 2(1+x^2) \sin x \cos x$

A-25: $y' = \frac{e^{3x}(3x^2 - 2x + 3)}{(1+x^2)^2}$

A-26: -40

A-27: $(1, 1)$ and $(-1, -1)$.

A-28: Always

A-29: $e^x \sec^3(5x-7)(1+15 \tan(5x-7))$

A-30: $e^{2x} \cos 4x + 2xe^{2x} \cos 4x - 4xe^{2x} \sin 4x$

A-31: $t = \frac{\pi}{4}$

A-32: Let $f(x) = e^{x+x^2}$ and $g(x) = 1+x$. Then $f(0) = g(0) = 1$.

$f'(x) = (1 + 2x)e^{x+x^2}$ and $g'(x) = 1$. When $x > 0$,

$$f'(x) = (1 + 2x)e^{x+x^2} > 1 \cdot e^{x+x^2} = e^{x+x^2} > e^{0+0^2} = 1 = g'(x).$$

Since $f(0) = g(0)$, and $f'(x) > g'(x)$ for all $x > 0$, that means f and g start at the same place, but f always grows faster. Therefore, $f(x) > g(x)$ for all $x > 0$.

A-33: $\cos(2x) = \cos^2 x - \sin^2 x$

A-34:

$$f'(x) = \frac{1}{3} \left(\frac{\sqrt{x^3 - 9} \tan x}{e^{\csc x^2}} \right)^{\frac{2}{3}} \cdot \left(\frac{\sqrt{x^3 - 9} \tan x (-2x) e^{\csc x^2} \csc(x^2) \cot(x^2) - e^{\csc x^2} \left(\frac{3x^2 \tan x}{2\sqrt{x^3 - 9}} + \sqrt{x^3 - 9} \sec^2 x \right)}{(\tan^2 x)(x^3 - 9)} \right)$$

A-35: (a)

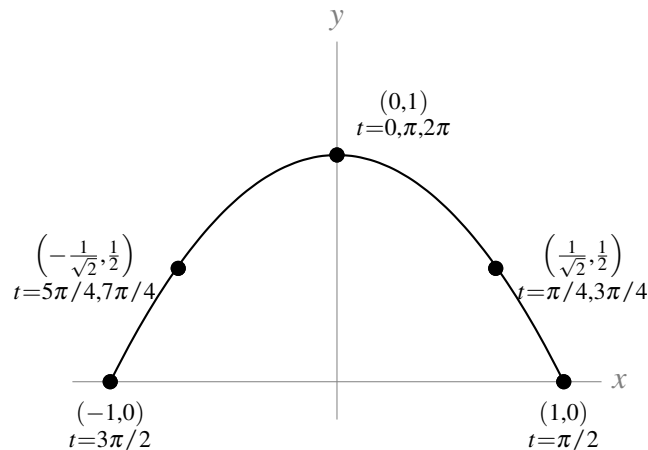

The particle traces the curve $y = 1 - x^2$ restricted to domain $[-1, 1]$. At $t = 0$, the particle is at the top of the curve, $(1, 0)$. Then it moves to the right, and goes back and forth along the curve, repeating its path every 2π units of time.

(b) $\sqrt{3}$

Answers to Exercises 4.4 — Jump to [TABLE OF CONTENTS](#)

A-1: Ten speakers: 13 dB. One hundred speakers: 23 dB.

A-2: $20 \log 2 \approx 14$ years

A-3: (b)

A-4: $f'(x) = \frac{1}{x}$

A-5: $f'(x) = \frac{2}{x}$

A-6: $f'(x) = \frac{2x+1}{x^2+x}$

A-7: $f'(x) = \frac{1}{x \log 10}$

A-8: $y' = \frac{1-3 \log x}{x^4}$

A-9: $\frac{d}{d\theta} \log(\sec \theta) = \tan \theta$

A-10: $f'(x) = \frac{-e^{\cos(\log x)} \sin(\log x)}{x}$

A-11: $y' = \frac{2x + \frac{4x^3}{2\sqrt{x^4+1}}}{x^2 + \sqrt{x^4+1}}$

A-12: $\frac{\tan x}{2\sqrt{-\log(\cos x)}}$

A-13: $\frac{\sqrt{x^2+4}+x}{x\sqrt{x^2+4}+x^2+4} = \frac{1}{\sqrt{x^2+4}}$

A-14: $g'(x) = \frac{2xe^{x^2}\sqrt{1+x^4}+2x^3}{e^{x^2}\sqrt{1+x^4}+1+x^4}$

A-15: $\frac{4}{3}$

A-16: $f'(x) = \frac{3x}{x^2+5} - \frac{2x^3}{x^4+10}$

A-17: $\frac{40}{3}$

A-18: $g'(x) = \pi^x \log \pi + \pi x^{\pi-1}$

A-19: $f'(x) = x^x(\log x + 1)$

A-20: $x^x(\log x + 1) + \frac{1}{x \log 10}$

A-21: $f'(x) = \frac{1}{4} \left(\sqrt[4]{\frac{(x^4+12)(x^4-x^2+2)}{x^3}} \right) \left(\frac{4x^3}{x^4+12} + \frac{4x^3-2x}{x^4-x^2+2} - \frac{3}{x} \right)$

A-22: $f'(x) = (x+1)(x^2+1)^2(x^3+1)^3(x^4+1)^4(x^5+1)^5 \left[\frac{1}{x+1} + \frac{4x}{x^2+1} + \frac{9x^2}{x^3+1} + \frac{16x^3}{x^4+1} + \frac{25x^4}{x^5+1} \right]$

A-23: $\left(\frac{x^2+2x+3}{3x^4+4x^3+5} \right) \left(\frac{1}{x^2+2x+3} - \frac{6x^2}{3x^4+4x^3+5} - \frac{1}{2(x+1)^2} \right)$

A-24: $f'(x) = (\cos x)^{\sin x} [(\cos x) \log(\cos x) - \sin x \tan x]$

A-25: $\frac{d}{dx} \{(\tan x)^x\} = (\tan x)^x \left(\log(\tan x) + \frac{x}{\sin x \cos x} \right)$

A-26: $2x(x^2 + 1)^{x^2+1}(1 + \log(x^2 + 1))$

A-27: $f'(x) = (x^2 + 1)^{\sin(x)} \cdot \left(\cos x \cdot \log(x^2 + 1) + \frac{2x \sin x}{x^2 + 1} \right)$

A-28: $\frac{d^3}{dx^3} \{ \log(5x^2 - 12) \} = \frac{100x(5x^2 + 36)}{(5x^2 - 12)^3}$

A-29: $x^{\cos^3(x)} \cdot \left(-3 \cos^2(x) \sin(x) \log(x) + \frac{\cos^3(x)}{x} \right)$

A-30: $(3 + \sin(x))^{x^2-3} \cdot \left[2x \log(3 + \sin(x)) + \frac{(x^2 - 3) \cos(x)}{3 + \sin(x)} \right]$

A-31: $\frac{d}{dx} \{ [f(x)]^{g(x)} \} = [f(x)]^{g(x)} \left[g'(x) \log(f(x)) + \frac{g(x) f'(x)}{f(x)} \right]$

A-32: Let $g(x) := \log(f(x))$. Notice $g'(x) = \frac{f'(x)}{f(x)}$.

In order to show that the two curves have horizontal tangent lines at the same values of x , we will show two things: first, that if $f(x)$ has a horizontal tangent line at some value of x , then also $g(x)$ has a horizontal tangent line at that value of x . Second, we will show that if $g(x)$ has a horizontal tangent line at some value of x , then also $f(x)$ has a horizontal tangent line at that value of x .

Suppose $f(x)$ has a horizontal tangent line where $x = x_0$ for some point x_0 . This means $f'(x_0) = 0$. Then $g'(x_0) = \frac{f'(x_0)}{f(x_0)}$. Since $f(x_0) \neq 0$, $\frac{f'(x_0)}{f(x_0)} = \frac{0}{f(x_0)} = 0$, so $g(x)$ also has a horizontal tangent line when $x = x_0$. This shows that whenever f has a horizontal tangent line, g has one too.

Now suppose $g(x)$ has a horizontal tangent line where $x = x_0$ for some point x_0 . This means $g'(x_0) = 0$. Then $g'(x_0) = \frac{f'(x_0)}{f(x_0)} = 0$, so $f'(x_0)$ exists and is equal to zero. Therefore, $f(x)$ also has a horizontal tangent line when $x = x_0$. This shows that whenever g has a horizontal tangent line, f has one too.

Answers to Exercises 4.5 — Jump to [TABLE OF CONTENTS](#)

A-1: (a) and (b)

A-2: At $(0, 4)$ and $(0, -4)$, $\frac{dy}{dx}$ is 0; at $(0, 0)$, $\frac{dy}{dx}$ does not exist.

A-3: (a) no (b) no

$\frac{dy}{dx} = -\frac{x}{y}$. It is not possible to write $\frac{dy}{dx}$ as a function of x , because (as stated in (b)) one value of x

may give two values of $\frac{dy}{dx}$. For instance, when $x = \pi/4$, at the point $\left(\frac{\pi}{4}, \frac{1}{\sqrt{2}}\right)$ the circle has slope

$\frac{dy}{dx} = -1$, while at the point $\left(\frac{\pi}{4}, \frac{-1}{\sqrt{2}}\right)$ the circle has slope $\frac{dy}{dx} = 1$.

A-4: The derivative $\frac{dy}{dx}$ is $\frac{11}{4}$ only at the point $(1, 3)$: it is not *constantly* $\frac{11}{4}$, so it is wrong to

differentiate the constant $\frac{11}{4}$ to find $\frac{d^2y}{dx^2}$. Below is a correct solution.

$$-28x + 2y + 2xy' + 2yy' = 0$$

Plugging in $x = 1, y = 3$:

$$\begin{aligned} -28 + 6 + 2y' + 6y' &= 0 \\ y' &= \frac{11}{4} \quad \text{at the point } (1, 3) \end{aligned}$$

Differentiating the equation $-28x + 2y + 2xy' + 2yy' = 0$:

$$\begin{aligned} -28 + 2y' + 2y' + 2xy'' + 2y'y' + 2yy'' &= 0 \\ 4y' + 2(y')^2 + 2xy'' + 2yy'' &= 28 \end{aligned}$$

At the point $(1, 3), y' = \frac{11}{4}$. Plugging in:

$$\begin{aligned} 4\left(\frac{11}{4}\right) + 2\left(\frac{11}{4}\right)^2 + 2(1)y'' + 2(3)y'' &= 28 \\ y'' &= \frac{15}{64} \end{aligned}$$

A-5: $\frac{dy}{dx} = -\frac{e^x + y}{e^y + x}$

A-6: $\frac{dy}{dx} = \frac{y^2 + 1}{e^y - 2xy}$

A-7: At $(x, y) = (4, 1), y' = -\frac{1}{\pi + 1}$. At $(x, y) = (-4, 1), y' = \frac{1}{\pi - 1}$.

A-8: -4

A-9: $-\frac{2x \sin(x^2 + y) + 3x^2}{4y^3 + \sin(x^2 + y)}$

A-10: At $(x, y) = (1, 0), y' = -6$, and at $(x, y) = (-5, 0), y' = \frac{6}{25}$.

A-11: $\frac{d^2y}{dx^2} = \frac{-1}{y^3}$

A-12: $\frac{dy}{dx} = \frac{\cos(x + y) - 2x}{2y - \cos(x + y)}$

A-13: At $(x, y) = (2, 0)$ we have $y' = -\frac{3}{2}$, and at $(x, y) = (-4, 0)$ we have $y' = -\frac{3}{4}$.

A-14: $\left(\frac{\sqrt{3}}{2}, \frac{-1}{2\sqrt{3}}\right), \left(\frac{-\sqrt{3}}{2}, \frac{1}{2\sqrt{3}}\right)$

A-15: $-\frac{28}{3}$

A-16: $\frac{dy}{dx} = -\frac{2xy^2 + \sin y}{2x^2y + x \cos y}$

A-17: $f''(x) = \frac{1}{x}$

A-18: At $(x, y) = (2, 0)$, $y' = -2$. At $(x, y) = (-2, 0)$, $y' = 2$.

A-19: $x = 0$, $x = 1$, $x = -1$

A-20:

(a) $y'(1) = \frac{4}{13}$

(b)

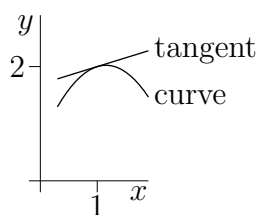

No exercises for Section 4.6. — Jump to [TABLE OF CONTENTS](#)

Answers to Exercises 4.7 — Jump to [TABLE OF CONTENTS](#)

A-1: (a) $(-\infty, \infty)$ (b) all integer multiples of π (c) $[-1, 1]$

A-2: False

A-3:

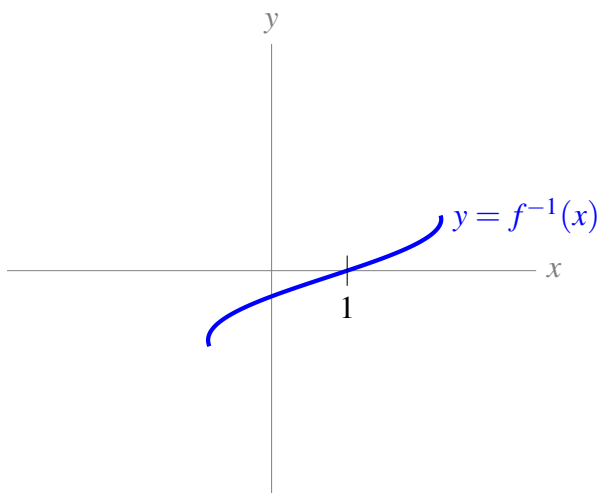

A-4:

- If $|a| > 1$, there is no point where the curve has horizontal tangent line.

- If $|a| = 1$, the curve has a horizontal tangent line where $x = 2\pi n + \frac{a\pi}{2}$ for any integer n .
- If $|a| < 1$, the curve has a horizontal tangent line where $x = 2\pi n + \arcsin(a)$ or $x = (2n + 1)\pi - \arcsin(a)$ for any integer n .

A-5: Domain: $x = \pm 1$. Not differentiable anywhere.

A-6: $f'(x) = \frac{1}{\sqrt{9-x^2}}$; domain of f is $[-3, 3]$.

A-7: $f'(t) = \frac{-\frac{t^2-1}{\sqrt{1-t^2}} - 2t \arccos t}{(t^2-1)^2}$, and the domain of $f(t)$ is $(-1, 1)$.

A-8: The domain of $f(x)$ is all real numbers, and $f'(x) = \frac{-2x}{(x^2+2)\sqrt{x^4+4x^2+3}}$.

A-9: $f'(x) = \frac{1}{a^2+x^2}$ and the domain of $f(x)$ is all real numbers.

A-10: $f'(x) = \arcsin x$, and the domain of $f(x)$ is $[-1, 1]$.

A-11: $x = 0$

A-12: $\frac{d}{dx}\{\arcsin x + \arccos x\} = 0$

A-13: $y' = \frac{-1}{x^2\sqrt{1-\frac{1}{x^2}}}$

A-14: $\frac{d^2}{dx^2}\{\arctan x\} = \frac{-2x}{(1+x^2)^2}$

A-15: $y' = \frac{-1}{1+x^2}$

A-16: $2x \arctan x + 1$

A-17: Let $\theta = \arctan x$. Then θ is the angle of a right triangle that gives $\tan \theta = x$. In particular, the ratio of the opposite side to the adjacent side is x . So, we have a triangle that looks like this:

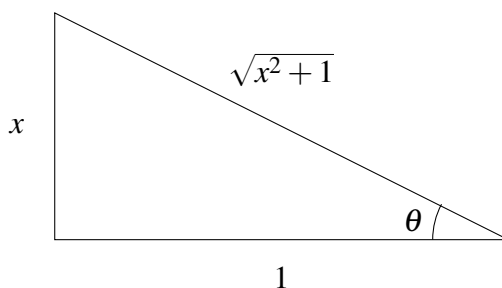

where the length of the hypotenuse came from the Pythagorean Theorem. Now,

$$\sin(\arctan x) = \sin \theta = \frac{\text{opp}}{\text{hyp}} = \frac{x}{\sqrt{x^2 + 1}}$$

From here, we differentiate using the quotient rule:

$$\begin{aligned} \frac{d}{dx} \left\{ \frac{x}{\sqrt{x^2+1}} \right\} &= \frac{\sqrt{x^2+1} - x \frac{2x}{2\sqrt{x^2+1}}}{x^2+1} \\ &= \left(\frac{\sqrt{x^2+1} - \frac{x^2}{\sqrt{x^2+1}}}{x^2+1} \right) \cdot \frac{\sqrt{x^2+1}}{\sqrt{x^2+1}} \\ &= \frac{(x^2+1) - x^2}{(x^2+1)^{3/2}} \\ &= \frac{1}{(x^2+1)^{3/2}} = (x^2+1)^{-3/2} \end{aligned}$$

A-18: Let $\theta = \arcsin x$. Then θ is the angle of a right triangle that gives $\sin \theta = x$. In particular, the ratio of the opposite side to the hypotenuse is x . So, we have a triangle that looks like this:

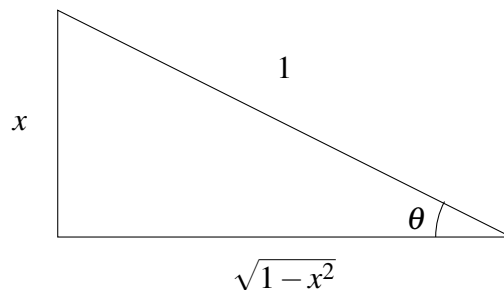

where the length of the adjacent side came from the Pythagorean Theorem. Now,

$$\cot(\arcsin x) = \cot \theta = \frac{\text{adj}}{\text{opp}} = \frac{\sqrt{1-x^2}}{x}$$

From here, we differentiate using the quotient rule:

$$\begin{aligned} \frac{d}{dx} \left\{ \frac{\sqrt{1-x^2}}{x} \right\} &= \frac{x \frac{-2x}{2\sqrt{1-x^2}} - \sqrt{1-x^2}}{x^2} \\ &= \frac{-x^2 - (1-x^2)}{x^2\sqrt{1-x^2}} \\ &= \frac{-1}{x^2\sqrt{1-x^2}} \end{aligned}$$

A-19: $(x, y) = \pm \left(\frac{\sqrt{3}}{2}, \frac{\pi}{3} \right)$

A-20: $x = \frac{(2n+1)\pi}{2}$ for any integer n

A-21: $g'(y) = \frac{1}{1 - \sin g(y)}$

A-22: $\frac{1}{2}$

A-23: $\frac{1}{e+1}$

A-24: $f'(x) = [\sin x + 2]^{\operatorname{arcsec} x} \left(\frac{\log[\sin x + 2]}{|x|\sqrt{x^2 - 1}} + \frac{\operatorname{arcsec} x \cdot \cos x}{\sin x + 2} \right)$. The domain of $f(x)$ is $|x| \geq 1$.

A-25: The function $\frac{1}{\sqrt{x^2 - 1}}$ exists only for those values of x with $x^2 - 1 > 0$: that is, the domain of $\frac{1}{\sqrt{x^2 - 1}}$ is $|x| > 1$. However, the domain of arcsine is $|x| \leq 1$. So, there is not one single value of x where $\arcsin x$ and $\frac{1}{\sqrt{x^2 - 1}}$ are both defined.

If the derivative of $\arcsin(x)$ were given by $\frac{1}{\sqrt{x^2 - 1}}$, then the derivative of $\arcsin(x)$ would not exist anywhere, so we would probably just write “derivative does not exist,” instead of making up a function with a mismatched domain. Also, the function $f(x) = \arcsin(x)$ is a smooth curve—its derivative exists at every point strictly inside its domain. (Remember not all curves are like this: for instance, $g(x) = |x|$ does not have a derivative at $x = 0$, but $x = 0$ is strictly inside its domain.) So, it’s a pretty good bet that the derivative of arcsine is *not* $\frac{1}{\sqrt{x^2 - 1}}$.

A-26: $\frac{1}{2}$

A-27: $f^{-1}(7) = -\frac{25}{4}$

A-28: $f(0) = -7$

A-29: $y' = \frac{2x\sqrt{1 - (x + 2y)^2} - 1}{2 - 2y\sqrt{1 - (x + 2y)^2}}$, or equivalently, $y' = \frac{2x\cos(x^2 + y^2) - 1}{2 - 2y\cos(x^2 + y^2)}$

Answers to Exercises 5 — Jump to [TABLE OF CONTENTS](#)

A-1: ii and iv

A-2: $-\frac{3}{2}$

A-3: 6%

A-4: (a) 0 (b) $100\frac{F'}{F} = 15\%$, or $F' = 0.15F$

A-5: $-\frac{17}{5}$ units per second

A-6: $\frac{4}{5}$ units per second

A-7: increasing at 7 mph

A-8: 8 cm per minute

A-9: $-\frac{13}{6}$ metres per second

A-10: The height of the water is decreasing at $\frac{3}{16} = 0.1875 \frac{\text{cm}}{\text{min}}$.

A-11: $\frac{1}{29200}$ metres per second (or about 1 centimetre every five minutes)

A-12: $\left(\frac{2}{\left(\frac{1235}{72}\right)^2 + 4}\right) \left(\frac{6175}{3}\right) \approx 13.8 \frac{\text{rad}}{\text{hour}} \approx 0.0038 \frac{\text{rad}}{\text{sec}}$

A-13: (a) $\frac{24}{13} \approx 1.85$ km/min (b) about .592 radians/min

A-14: $\frac{55\sqrt{21}\pi}{42} \approx 19$ centimetres per hour.

A-15: $\frac{dA}{dt} = -2\pi \frac{\text{cm}^2}{\text{s}}$

A-16: 288π cubic units per unit time

A-17: 0 square centimetres per minute

A-18: $-\frac{7\pi}{12} \approx -1.8 \frac{\text{cm}^3}{\text{sec}^2}$

A-19: The flow is decreasing at a rate of $\frac{\sqrt{7}}{1000} \frac{\text{m}^3}{\text{sec}^2}$.

A-20: $\frac{-15}{49\pi} \approx -0.097$ cm per minute

A-21: (a) $\frac{dD}{dt} = \frac{1}{2\sqrt{2}}$ metres per hour

(b) The river is higher than 2 metres.

(c) The river's flow has reversed direction. (This can happen near an ocean at high tide.)

A-22: (a) 2 units per second (b) Its y -coordinate is decreasing at $\frac{1}{2}$ unit per second.

The point is moving at $\frac{\sqrt{5}}{2}$ units per second.

A-23: (a) $10\pi = \pi \left[3(a+b) - \sqrt{(a+3b)(3a+b)}\right]$ or equivalently,

$$10 = 3(a+b) - \sqrt{(a+3b)(3a+b)}$$

(b) $20\pi ab$

(c) The water is spilling out at about 375.4 cubic centimetres per second. The exact amount is

$$-\frac{200\pi}{9 - \sqrt{35}} \left(1 - 2 \left(\frac{3\sqrt{35} - 11}{3\sqrt{35} - 13}\right)\right) \frac{\text{cm}^3}{\text{sec}}.$$

A-24: $B(10) = 0$

Answers to Exercises 6 — Jump to [TABLE OF CONTENTS](#)

A-1: There are many possible answers. Here is one: $f(x) = 5x$, $g(x) = 2x$.

A-2: There are many possible answers. Here is one: $f(x) = x$, $g(x) = x^2$.

A-3: $-\frac{2}{\pi}$

A-4: $-\infty$

A-5: 0

A-6: 0

A-7: 3

A-8: 2

A-9: 0

A-10: $\frac{1}{2}$

A-11: 0

A-12: 5

A-13: 3

A-14: $\frac{3}{2}$

A-15: 0

A-16: $\frac{1}{3}$

A-17: $c = 0$

A-18: $\lim_{x \rightarrow 0} \frac{e^{k \sin(x^2)} - (1 + 2x^2)}{x^4} = \begin{cases} -\infty & k < 2 \\ 2 & k = 2 \\ \infty & k > 2 \end{cases}$

A-19:

- We want to find the limit as n goes to infinity of the percentage error, $\lim_{n \rightarrow \infty} 100 \frac{|S(n) - A(n)|}{|S(n)|}$.

Since $A(n)$ is a nicer function than $S(n)$, let's simplify:

$$\lim_{n \rightarrow \infty} 100 \frac{|S(n) - A(n)|}{|S(n)|} = 100 \left| 1 - \lim_{n \rightarrow \infty} \frac{A(n)}{S(n)} \right|.$$

We figure out this limit the natural way:

$$\begin{aligned} 100 \left| 1 - \lim_{n \rightarrow \infty} \frac{A(n)}{S(n)} \right| &= 100 \left| 1 - \lim_{n \rightarrow \infty} \frac{5n^4}{\underbrace{5n^4 - 13n^3 - 4n + \log(n)}_{\substack{\text{num} \rightarrow \infty \\ \text{den} \rightarrow \infty}}} \right| \\ &= 100 \left| 1 - \lim_{n \rightarrow \infty} \frac{20n^3}{20n^3 - 39n^2 - 4 + \frac{1}{n}} \right| \\ &= 100 \left| 1 - \lim_{n \rightarrow \infty} \frac{n^3}{n^3} \cdot \frac{20}{20 - \frac{39}{n} - \frac{4}{n^3} + \frac{1}{n^4}} \right| \\ &= 100 |1 - 1| = 0 \end{aligned}$$

So, as n gets larger and larger, the relative error in the approximation gets closer and closer to 0.

- Now, let's look at the absolute error.

$$\lim_{n \rightarrow \infty} |S(n) - A(n)| = \lim_{n \rightarrow \infty} |-13n^3 - 4n + \log n| = \infty$$

So although the error gets small *relative to the giant numbers we're talking about*, the absolute error grows without bound.

A-20: There are many possible answers. Here is one: $f(x) = 1 + \frac{1}{x}$, $g(x) = x \log 5$ (recall we use \log to mean logarithm base e).

A-21: 0

A-22: $\frac{1}{\sqrt{e}}$

A-23: 1

A-24: 1

Answers to Exercises 7.1 — Jump to [TABLE OF CONTENTS](#)

A-1: In general, false.

A-2: $f(x) = A(x)$ $g(x) = C(x)$ $h(x) = B(x)$ $k(x) = D(x)$

A-3: (a) $p = e^2$ (b) $b = -e^2$ $1 - e^2$

A-4: vertical asymptote at $x = 3$; horizontal asymptotes $\lim_{x \rightarrow \pm\infty} f(x) = \frac{2}{3}$

A-5: horizontal asymptote $y = 0$ as $x \rightarrow -\infty$; no other asymptotes

Answers to Exercises 7.2 — Jump to [TABLE OF CONTENTS](#)

A-1: $A'(x) = l(x)$ $B'(x) = p(x)$ $C'(x) = n(x)$ $D'(x) = o(x)$ $E'(x) = m(x)$

A-2: $(-2, \infty)$

A-3: $(1, 4)$

A-4: $(-\infty, 1)$

Answers to Exercises 7.3 — Jump to [TABLE OF CONTENTS](#)

A-1:

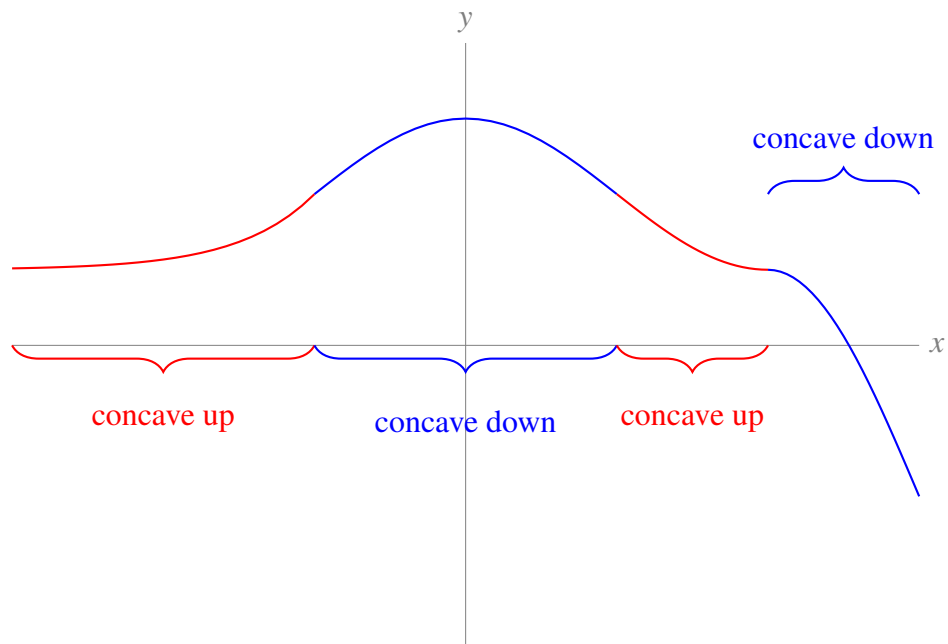

A-2:

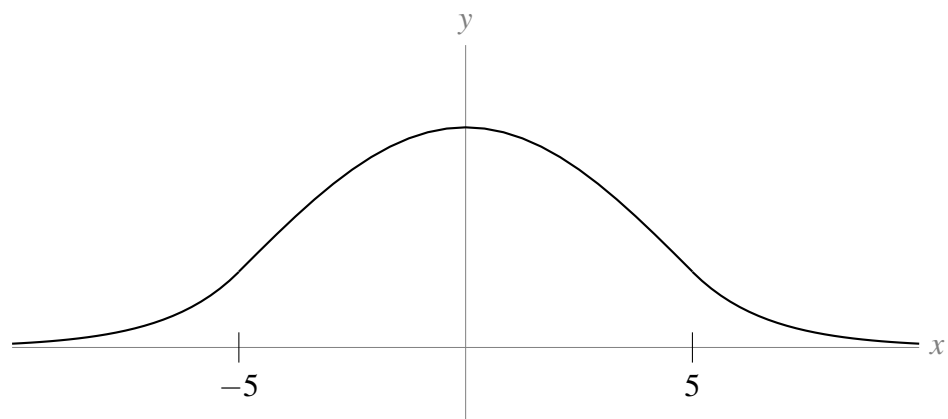

A-3: In general, false.

A-4: $x = 1, y = 11$

Answers to Exercises 7.4 — Jump to [TABLE OF CONTENTS](#)

A-1: even

A-2: odd, periodic

A-3:

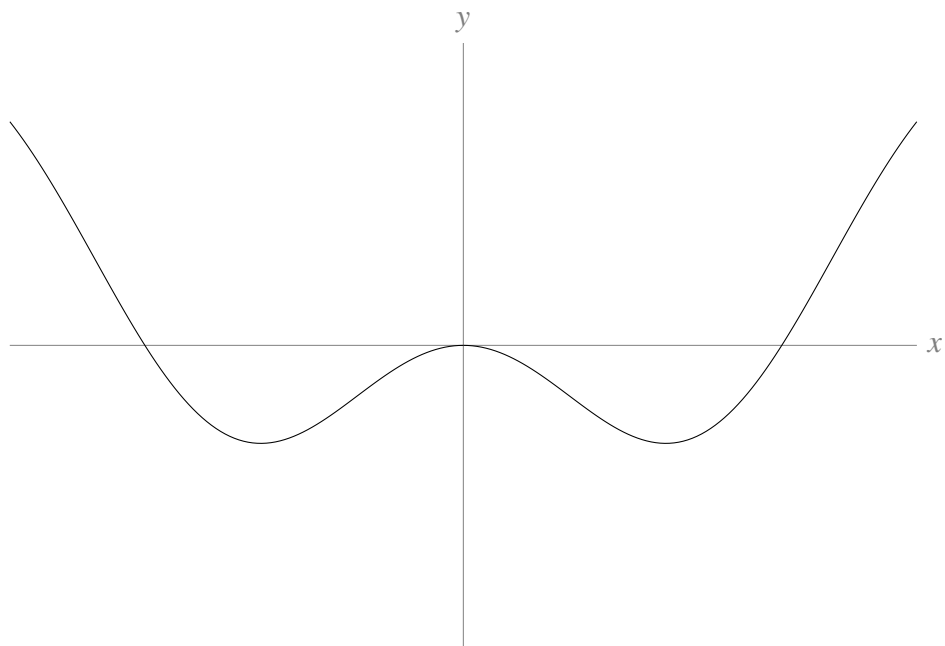

A-4:

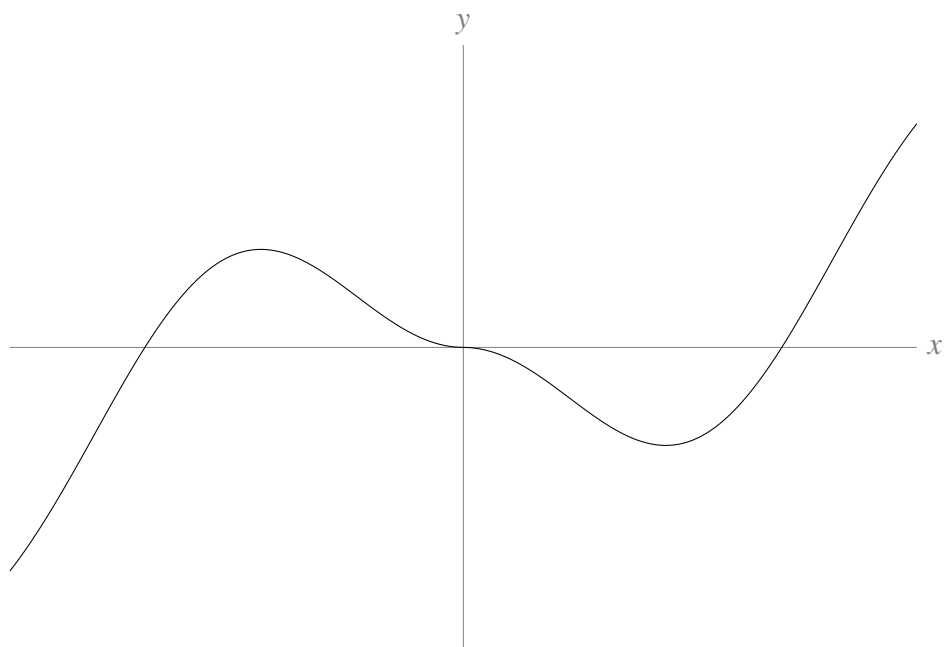

A-5: A function is even if $f(-x) = f(x)$.

$$\begin{aligned} f(-x) &= \frac{(-x)^4 - (-x)^6}{e^{(-x)^2}} \\ &= \frac{x^4 - x^6}{e^{x^2}} \\ &= f(x) \end{aligned}$$

So, $f(x)$ is even.

A-6: For any real number x , we will show that $f(x) = f(x + 4\pi)$.

$$\begin{aligned} f(x + 4\pi) &= \sin(x + 4\pi) + \cos\left(\frac{x + 4\pi}{2}\right) \\ &= \sin(x + 4\pi) + \cos\left(\frac{x}{2} + 2\pi\right) \\ &= \sin(x) + \cos\left(\frac{x}{2}\right) \\ &= f(x) \end{aligned}$$

So, $f(x)$ is periodic.

A-7: even

A-8: none

A-9: 1

A-10: π

No exercises for Section 7.5. — Jump to [TABLE OF CONTENTS](#)

Answers to Exercises 7.6 — Jump to [TABLE OF CONTENTS](#)

A-1: (a) $(-\infty, 3]$

(b) $f(x)$ is increasing on $(-\infty, 2)$ and decreasing on $(2, 3)$. There is a local maximum at $x = 2$ and a local minimum at the endpoint $x = 3$.

(c) $f(x)$ is always concave down and has no inflection points.

(d) $(3, 0)$

(e)

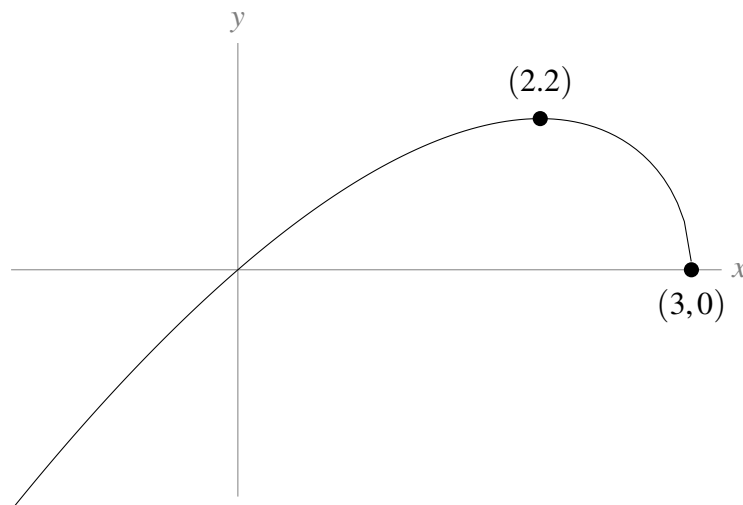

A-2: The open dot is the inflection point, and the closed dot is the local and global maximum.

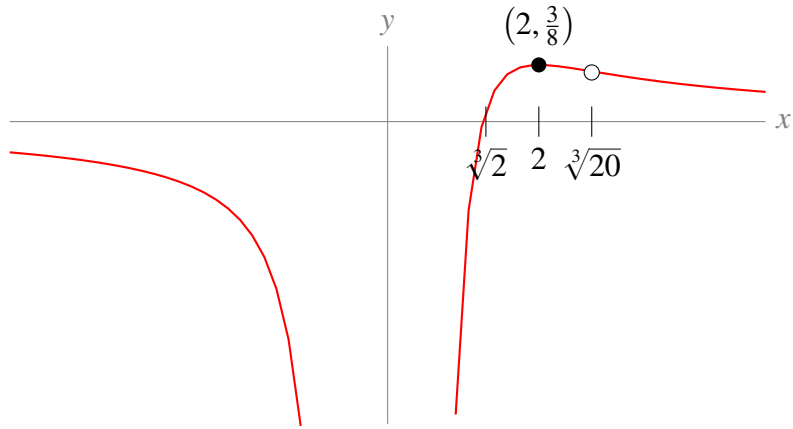

A-3: The open dot marks the inflection point.

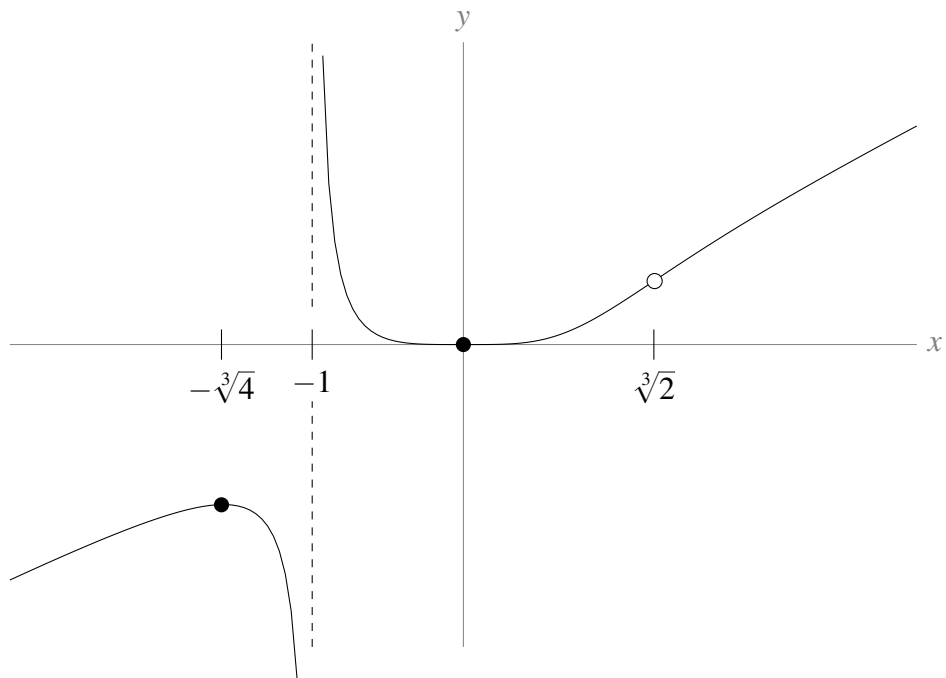

A-4:

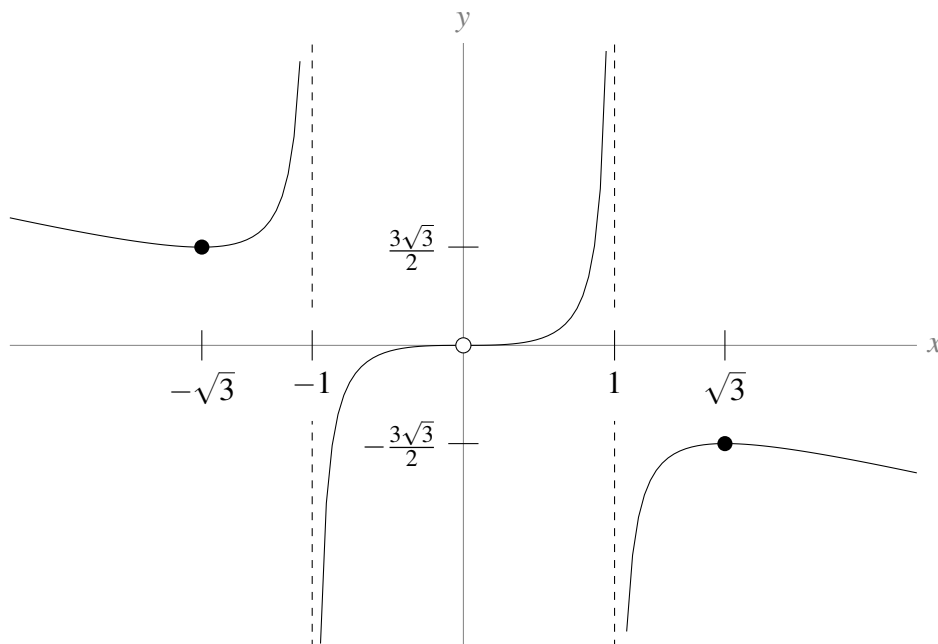

A-5: (a) One branch of the function, the exponential function e^x , is continuous everywhere. So $f(x)$ is continuous for $x < 0$. When $x \geq 0$, $f(x) = \frac{x^2 + 3}{3(x+1)}$, which is continuous whenever $x \neq -1$ (so it's continuous for all $x > 0$). So, $f(x)$ is continuous for $x > 0$. To see that $f(x)$ is continuous at $x = 0$, we see:

$$\begin{aligned} \lim_{x \rightarrow 0^-} f(x) &= \lim_{x \rightarrow 0^-} e^x = 1 \\ \lim_{x \rightarrow 0^+} f(x) &= \lim_{x \rightarrow 0^+} \frac{x^2 + 3}{3(x+1)} = 1 \\ \text{So, } \lim_{x \rightarrow 0} f(x) &= 1 = f(0) \end{aligned}$$

Hence $f(x)$ is continuous at $x = 0$, so $f(x)$ is continuous everywhere.

(b) i.

$f(x)$ is increasing for $x < 0$ and $x > 1$, decreasing for $0 < x < 1$, has a local max at $(0, 1)$, and has a local min at $(1, \frac{2}{3})$.

ii.

$f(x)$ is concave upwards for all $x \neq 0$.

iii.

The x -axis is a horizontal asymptote as $x \rightarrow -\infty$.

(c)

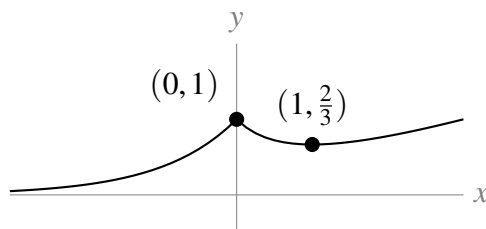

A-6:

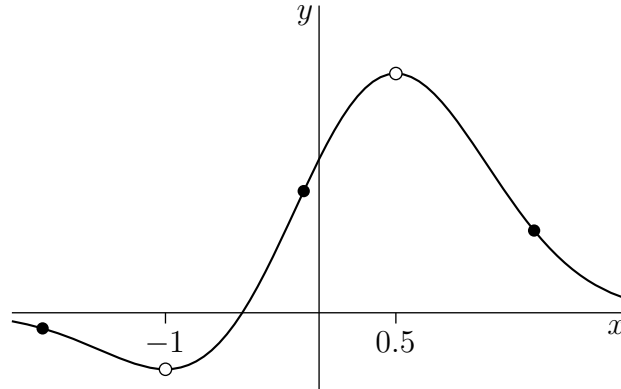

A-7: (a) Increasing: $(-1, 1)$ decreasing: $(-\infty, -1) \cup (1, \infty)$
 concave up: $(-\sqrt{3}, 0) \cup (\sqrt{3}, \infty)$ concave down: $(-\infty, -\sqrt{3}) \cup (0, \sqrt{3})$
 inflection points: $x = \pm\sqrt{3}, 0$

(b) The local and global minimum of $f(x)$ is at $(-1, \frac{-1}{\sqrt{e}})$, and the local and global maximum of $f(x)$ is at $(1, \frac{1}{\sqrt{e}})$.

(c) In the graph below, open dots are inflection points, and solid dots are extrema.

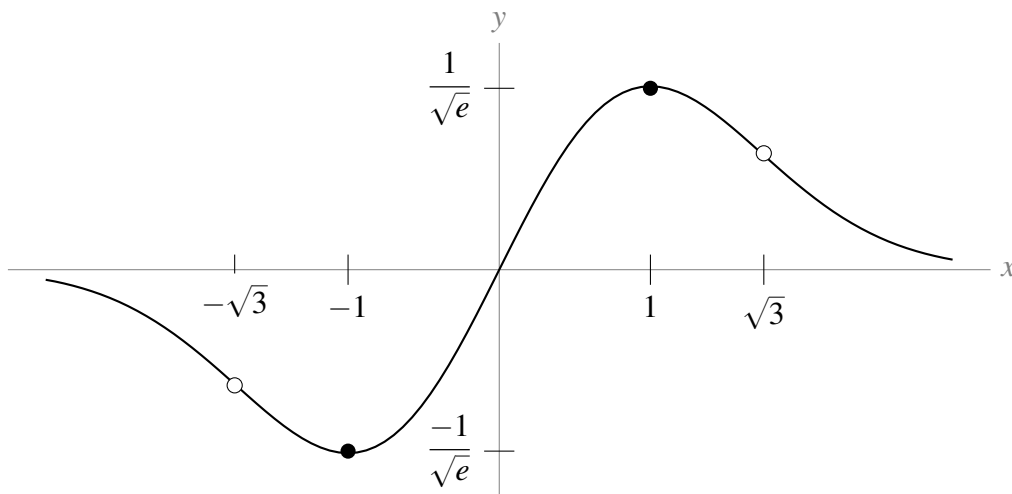

A-8: Local maxima occur at $x = \frac{2\pi}{3} + 2\pi n$ for all integers n , and local minima occur at $x = -\frac{2\pi}{3} + 2\pi n$ for all integers n . Inflection points occur at every integer multiple of π .

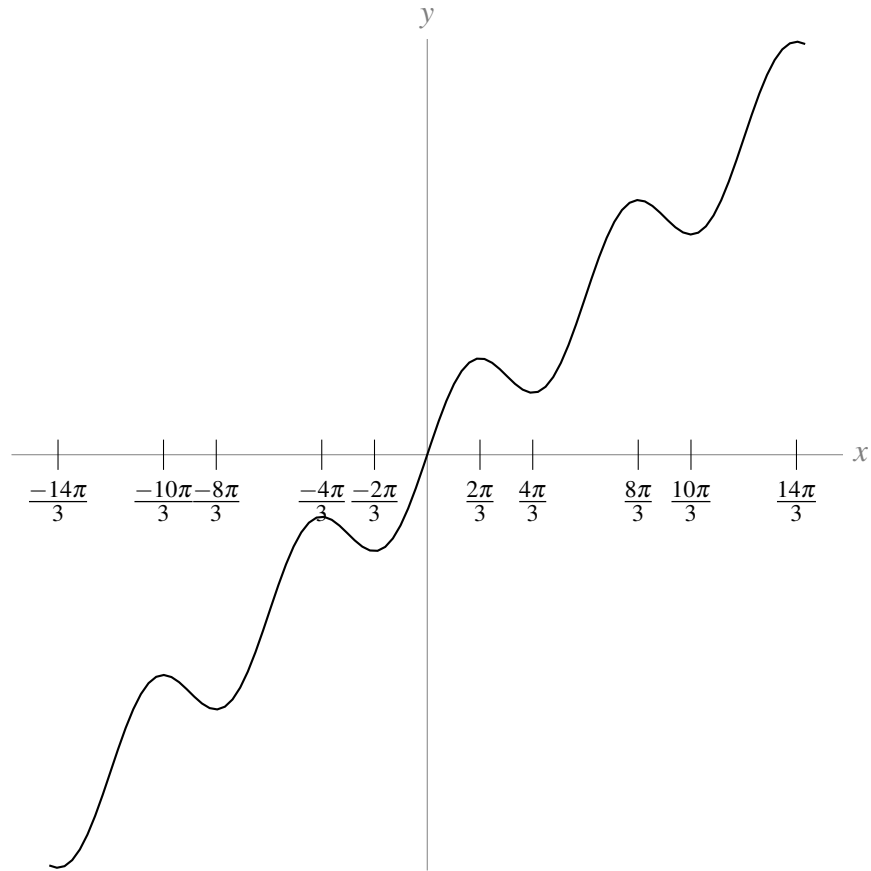

A-9: Below is the graph $y = f(x)$ over the interval $[-\pi, \pi]$. The sketch of the curve over a larger domain is simply a repetition of this figure.

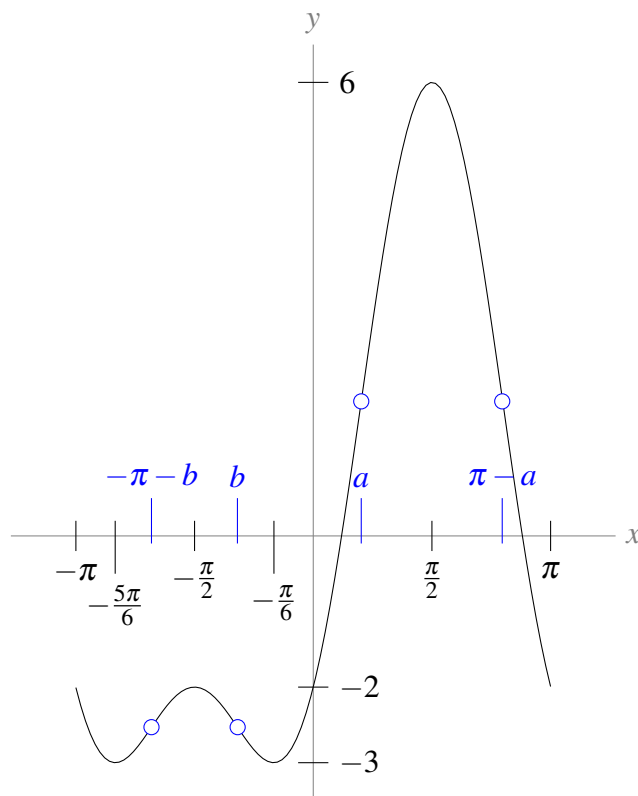

On the interval $[0, \pi]$, the maximum value of $f(x)$ is 6 and the minimum value is -2 .

Let $a = \sin^{-1}\left(\frac{-1 + \sqrt{33}}{8}\right) \approx 0.635 \approx 0.2\pi$ and $b = \sin^{-1}\left(\frac{-1 - \sqrt{33}}{8}\right) \approx -1.003 \approx -0.3\pi$.

The points $-\pi - b$, b , a , and $\pi - a$ are inflection points.

A-10: The closed dot is the local minimum, and the open dots are inflection points at $x = -1$ and $x = -2 \pm \sqrt{1.5}$. The graph has horizontal asymptotes $y = 0$ as x goes to $\pm\infty$.

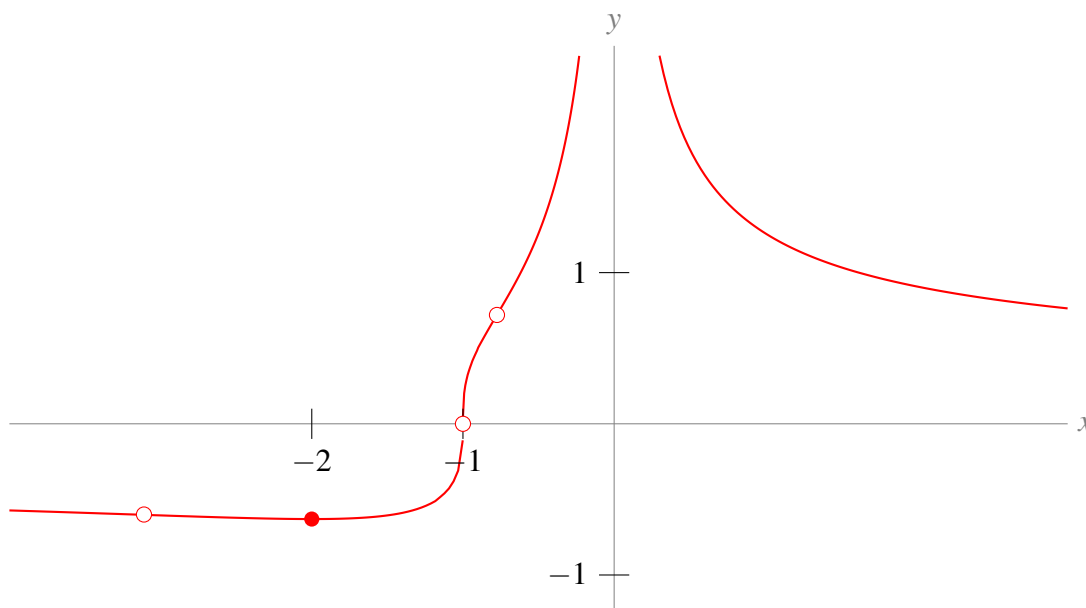

A-11: (a) decreasing for $x < 0$ and $x > 2$, increasing for $0 < x < 2$, minimum at $(0, 0)$, maximum at $(2, 2)$.

(b) concave up for $x < 2 - \sqrt{2}$ and $x > 2 + \sqrt{2}$, concave down for $2 - \sqrt{2} < x < 2 + \sqrt{2}$, inflection points at $x = 2 \pm \sqrt{2}$.

(c) ∞

(d) Open dots indicate inflection points, and closed dots indicate local extrema.

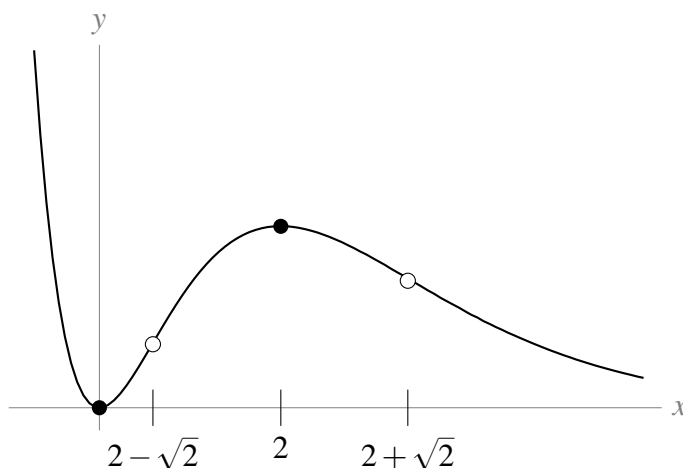

A-12: (a)

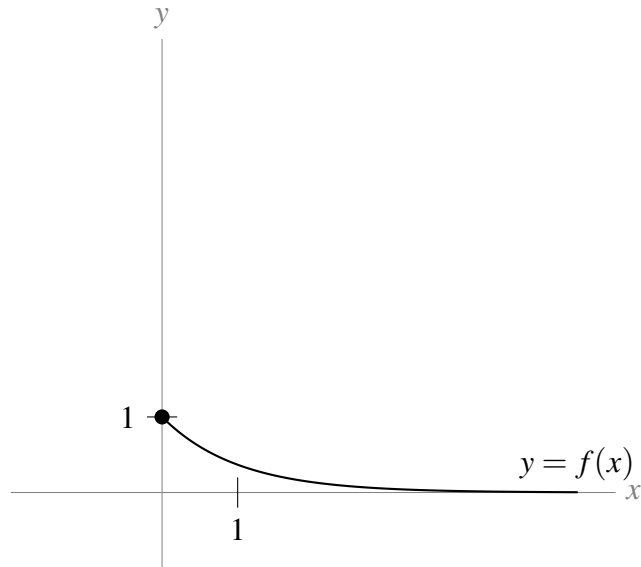

There are no inflection points or extrema, except the endpoint $(0, 1)$.

(b)

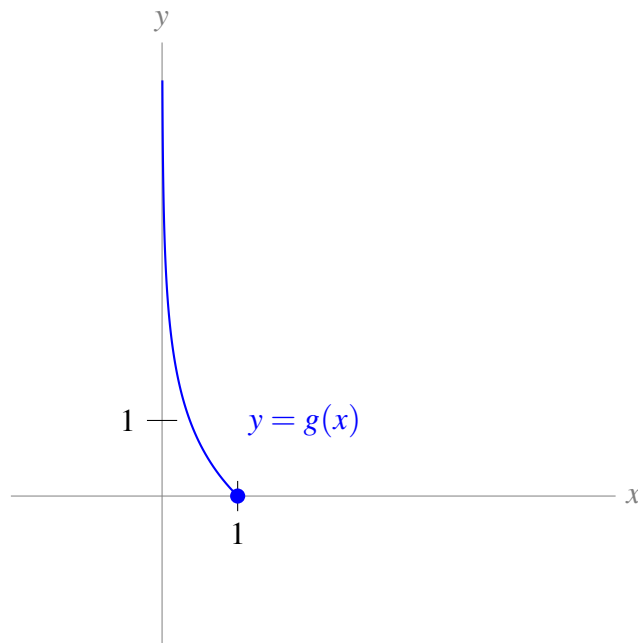

There are no inflection points or extrema, except the endpoint $(1, 0)$.

(c) The domain of g is $(0, 1]$. The range of g is $[0, \infty)$.

(d) $g'(\frac{1}{2}) = -2$

A-13: (a)

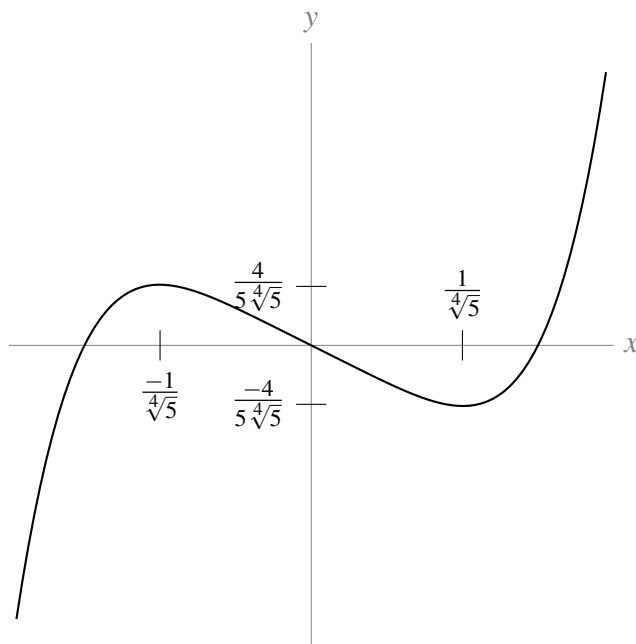

Local maximum at $x = -\frac{1}{\sqrt[4]{5}}$; local minimum at $x = \frac{1}{\sqrt[4]{5}}$; inflection point at the origin; concave down for $x < 0$; concave up for $x > 0$.

(b) The number of distinct real roots of $x^5 - x + k$ is:

- 1 when $|k| > \frac{4}{5\sqrt[4]{5}}$
- 2 when $|k| = \frac{4}{5\sqrt[4]{5}}$
- 3 when $|k| < \frac{4}{5\sqrt[4]{5}}$

A-14: (a)

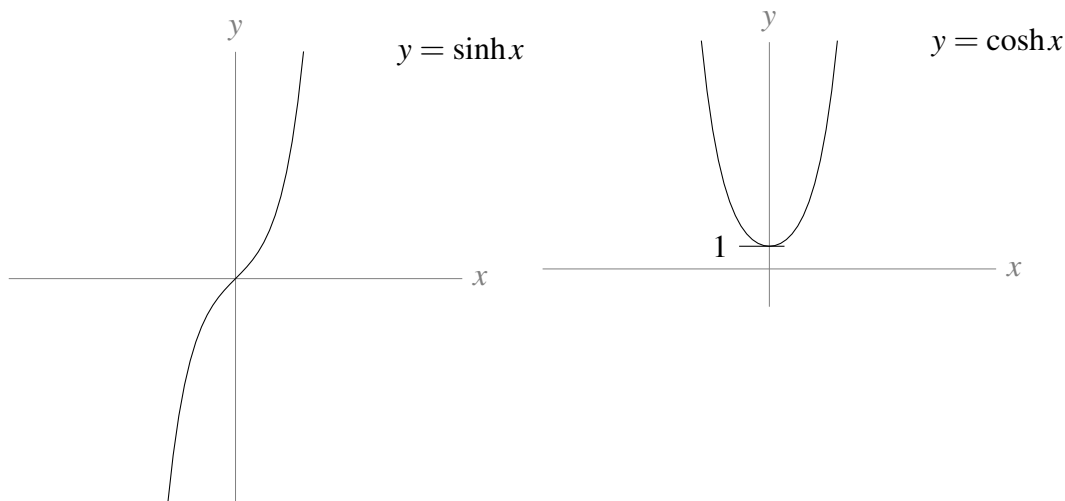

(b) For any real x , define $\sinh^{-1}(x)$ to be the unique solution of $\sinh(y) = x$. For every $x \in [1, \infty)$, define $\cosh^{-1}(x)$ to be the unique $y \in [0, \infty)$ that obeys $\cosh(y) = x$.

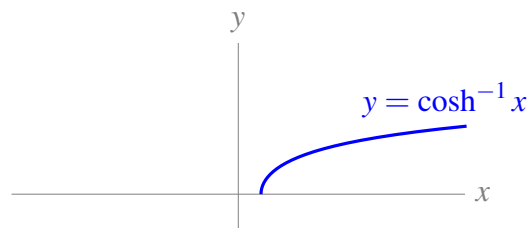
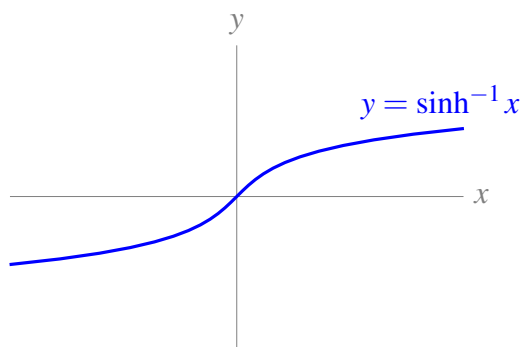

$$(c) \frac{d}{dx} \{ \cosh^{-1}(x) \} = \frac{1}{\sqrt{x^2 - 1}}$$

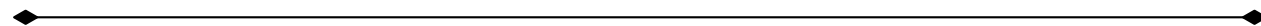

Answers to Exercises 8.1 — Jump to [TABLE OF CONTENTS](#)

A-1:

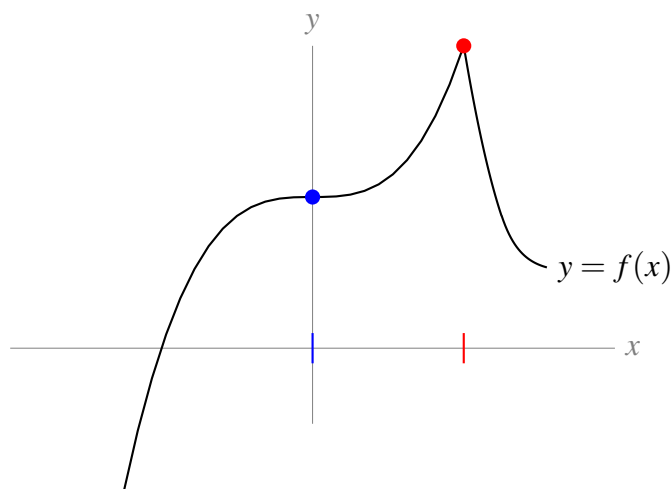

There is a critical point at $x = 0$. The x -value of the red dot is a singular point, and a local maximum occurs there.

A-2:

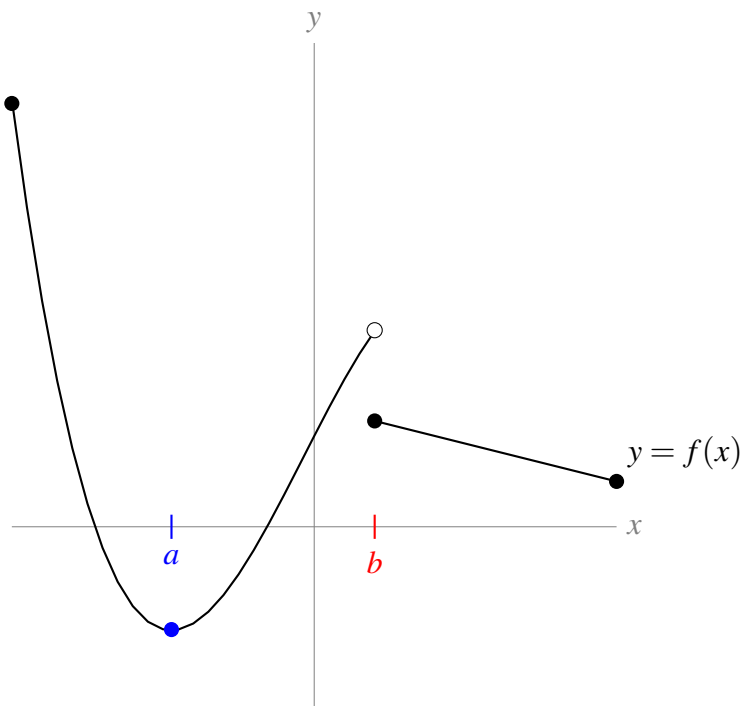

The x -coordinate corresponding to the blue dot (let's call it a) is a critical point, and $f(x)$ has a local and global minimum at $x = a$. The x -coordinate corresponding to the discontinuity (let's call it b) is a singular point, but there is not a global or local extremum at $x = b$.

A-3: One possible answer is shown below.

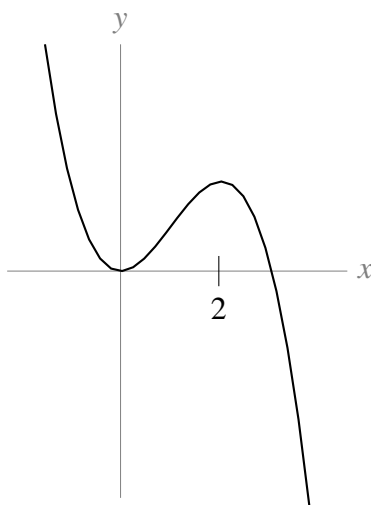

A-4: The critical points are $x = 3$ and $x = -1$. These two points are the only places where local extrema might exist. There are no singular points.

A-5:

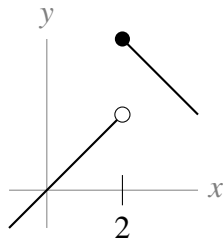

local max

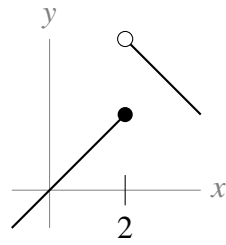

neither

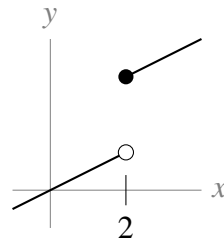

neither

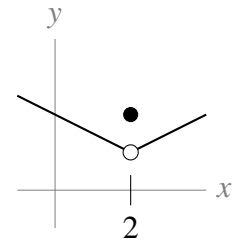

local max

A-6: There are many possible answers. Every answer must have $x = 2$ as a singular point strictly inside the domain of $f(x)$. Two possibilities are shown below.

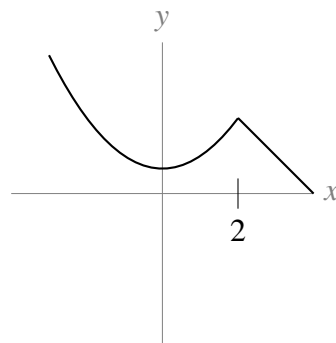
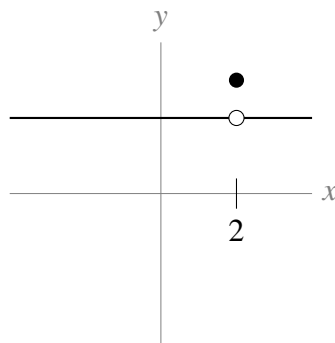

A-7: $x = -7$, $x = -1$, and $x = 5$

A-8: Every real number c is a critical point of $f(x)$, and $f(x)$ has a local and global maximum and minimum at $x = c$. There are no singular points.

Answers to Exercises 8.2 — Jump to [TABLE OF CONTENTS](#)

A-1: Two examples are given below, but many are possible.

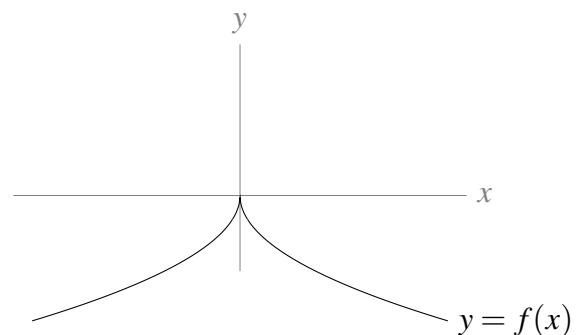
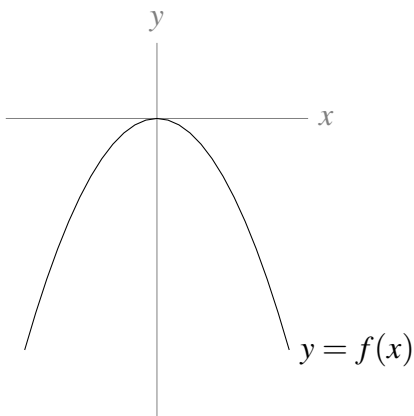

A-2: Two examples are given below, but many are possible.

-
- A-1: The global maximum is $f(-1) = 6$, the global minimum is $f(-2) = -20$.
- A-2: Global maximum is $f(2) = 12$, global minimum is $f(1) = -14$.
- A-3: Global maximum is $f(4) = 30$, global minimum is $f(2) = -10$.
- A-4: Local max at $(-2, 20)$, local min at $(2, -12)$.
- A-5: $(-2, 33)$ max, and $(2, -31)$ min
- A-6: Q should be $4\sqrt{3}$ kilometres from A
- A-7: $10 \times 30 \times 15$
- A-8: $2 \times 2 \times 6$
- A-9: $X = Y = \sqrt{2}$
- A-10: The largest possible perimeter is $2\sqrt{5}R$ and the smallest possible perimeter is $2R$.
- A-11: $\frac{A^{3/2}}{3\sqrt{6\pi}}$
- A-12: $\frac{P^2}{2(\pi + 4)}$
- A-13: (a) $x = \sqrt{\frac{A}{3p}}$, $y = \sqrt{\frac{Ap}{3}}$, and $z = \frac{\sqrt{Ap}}{\sqrt{3}(1+p)}$
- (b) $p = 1$
- (The dimensions of the resulting baking pan are $x = y = \sqrt{\frac{A}{3}}$ and $z = \frac{1}{2}\sqrt{\frac{A}{3}}$.)
- A-14: (a) $x^x(1 + \log x)$ (b) $x = \frac{1}{e}$ (c) local minimum
- A-15: Maximum area: do not cut, make a circle and no square.
 Minimum area: make a square out of a piece that is $\frac{4}{4 + \pi}$ of the total length of the wire.
-

Answers to Exercises 8.4 — Jump to [TABLE OF CONTENTS](#)

Answers to Exercises 9.1 — Jump to [TABLE OF CONTENTS](#)

A-1: Since $f(0)$ is closer to $g(0)$ than it is to $h(0)$, you would probably want to estimate $f(0) \approx g(0) = 1 + 2\sin(1)$ if you had the means to efficiently figure out what $\sin(1)$ is, and if you were concerned with accuracy. If you had a calculator, you could use this estimation. Also, later in this chapter we will learn methods of approximating $\sin(1)$ that do not require a calculator, but they do require time.

Without a calculator, or without a lot of time, using $f(0) \approx h(0) = 0.7$ probably makes the most sense. It isn't as accurate as $f(0) \approx g(0)$, but you get an estimate very quickly, without worrying about figuring out what $\sin(1)$ is.

A-2: $\log(0.93) \approx \log(1) = 0$

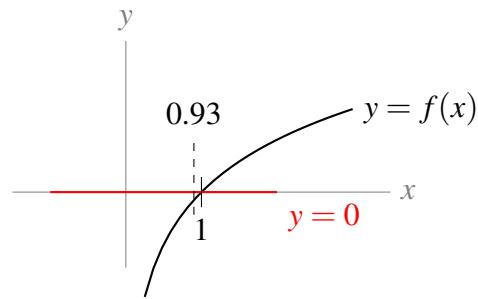

A-3: $\arcsin(0.1) \approx 0$

A-4: $\sqrt{3}\tan(1) \approx 3$

A-5: $10.1^3 \approx 10^3 = 1000$

Answers to Exercises 9.2 — Jump to [TABLE OF CONTENTS](#)

A-1: (a) $f(5) = 6$ (b) $f'(5) = 3$ (c) not enough information to know

A-2:

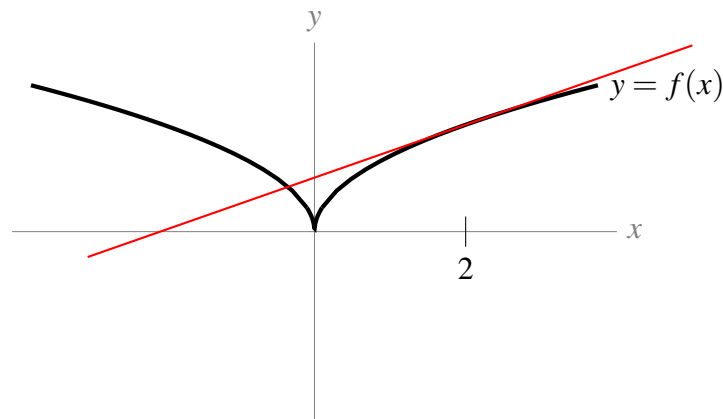

The linear approximation is shown in red.

A-3: $f(x) = 2x + 5$

A-4: $\log(0.93) \approx -0.07$

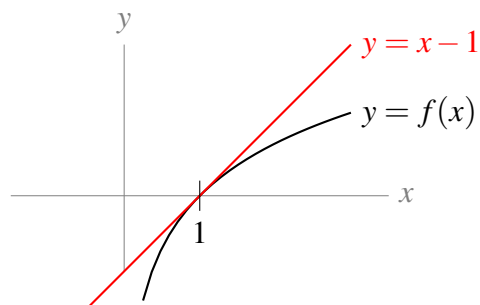

A-5: $\sqrt{5} \approx \frac{9}{4}$

A-6: $\sqrt[5]{30} \approx \frac{79}{40}$

A-7: $10.1^3 \approx 1030, 10.1^3 = 1030.301$

A-8: There are many possible answers. One is $f(x) = \sin x$, $a = 0$, and $b = \pi$.

A-9: $a = \sqrt{3}$

Answers to Exercises 9.3 — Jump to [TABLE OF CONTENTS](#)

A-1: $f(3) = 9, f'(3) = 0, f''(3) = -2$; there is not enough information to know $f'''(3)$.

A-2: $f(x) \approx 2x + 5$

A-3: $\log(0.93) \approx -0.07245$

A-4: $\cos\left(\frac{1}{15}\right) \approx \frac{449}{450}$

A-5: $e^{2x} \approx 1 + 2x + 2x^2$

A-6: One approximation: $e^{\frac{4}{3}} \approx \frac{275}{32}$

A-7: (a) 26 (b) 16 (c) $\frac{10}{11}$ (d) $\frac{75}{64}$

A-8: For each of these, there are many solutions. We provide some below.

(a) $1 + 2 + 3 + 4 + 5 = \sum_{n=1}^5 n$

(b) $2 + 4 + 6 + 8 = \sum_{n=1}^4 2n$

(c) $3 + 5 + 7 + 9 + 11 = \sum_{n=1}^5 (2n + 1)$

(d) $9 + 16 + 25 + 36 + 49 = \sum_{n=3}^7 n^2$

(e) $9 + 4 + 16 + 5 + 25 + 6 + 36 + 7 + 49 + 8 = \sum_{n=3}^7 (n^2 + n + 1)$

(f) $8 + 15 + 24 + 35 + 48 = \sum_{n=3}^7 (n^2 - 1)$

(g) $3 - 6 + 9 - 12 + 15 - 18 = \sum_{n=1}^6 (-1)^{n+1} 3n$

A-9: $f(1) \approx 2, f(1) = \pi$

A-10: $e \approx 2.5$

A-11: $\{(a),(d),(e)\}, \{(b),(g)\}, \{(c),(f)\}$

Answers to Exercises 9.4 — Jump to [TABLE OF CONTENTS](#)

A-1: $f''(1) = -4$

A-2: $f^{(10)}(5) = 10!$

A-3: $T_3(x) = -x^3 + x^2 - x + 1$

A-4: $T_3(x) = -7 + 7(x-1) + 9(x-1)^2 + 5(x-1)^3$, or equivalently, $T_3(x) = 5x^3 - 6x^2 + 4x - 10$

A-5: $f^{(10)}(5) = \frac{11 \cdot 10!}{6}$

A-6: $a = \sqrt{e}$

Answers to Exercises 9.5 — Jump to [TABLE OF CONTENTS](#)

A-1:

$$T_{16}(x) = 1 + x - \frac{1}{2}x^2 - \frac{1}{3!}x^3 + \frac{1}{4!}x^4 + \frac{1}{5!}x^5 - \frac{1}{6!}x^6 - \frac{1}{7!}x^7 + \frac{1}{8!}x^8 + \frac{1}{9!}x^9 - \frac{1}{10!}x^{10} - \frac{1}{11!}x^{11} \\ + \frac{1}{12!}x^{12} + \frac{1}{13!}x^{13} - \frac{1}{14!}x^{14} - \frac{1}{15!}x^{15} + \frac{1}{16!}x^{16}$$

A-2: $T_{100}(t) = 127.5 + 48(t-5) + 4.9(t-5)^2 = 4.9t^2 - t + 10$

A-3: $T_n(x) = \sum_{k=0}^n \frac{2(\log 2)^k}{k!} (x-1)^k$

A-4: $T_6(x) = 7 + 5(x-1) + \frac{7}{2}(x-1)^2 + \frac{1}{3}(x-1)^3 - \frac{1}{12}(x-1)^4 + \frac{1}{30}(x-1)^5 - \frac{1}{60}(x-1)^6$

A-5: $T_n(x) = \sum_{k=0}^n x^k$

A-6: $T_3(x) = 1 + (x-1) + (x-1)^2 + \frac{1}{2}(x-1)^3$

A-7: $\pi = 6 \arctan\left(\frac{1}{\sqrt{3}}\right) \approx \frac{82}{45}\sqrt{3} \approx 3.156$

A-8: $T_{100}(x) = -1 + \sum_{k=2}^{100} \frac{(-1)^k}{k(k-1)} (x-1)^k$

A-9: $T_{2n}(x) = \sum_{\ell=0}^n \frac{(-1)^\ell}{(2\ell)!\sqrt{2}} (x - \frac{\pi}{4})^{2\ell} + \sum_{\ell=0}^{n-1} \frac{(-1)^\ell}{(2\ell+1)!\sqrt{2}} (x - \frac{\pi}{4})^{2\ell+1}$

A-10:

$$1 + \frac{1}{2} + \frac{1}{3!} + \frac{1}{4!} + \cdots + \frac{1}{157!} \approx e - 1$$

A-11: We estimate that the sum is close to $-\frac{1}{\sqrt{2}}$.

Answers to Exercises 9.6 — Jump to [TABLE OF CONTENTS](#)

A-1: (a) False (b) True (c) True (d) True

A-2: Equation 9.6.6 gives us the bound $|f(2) - T_3(2)| < 6$. A calculator tells us actually $|f(2) - T_3(2)| \approx 1.056$.

A-3: $|f(37) - T(37)| = 0$

A-4: You do, you clever goose!

A-5: $|f(11.5) - T_5(11.5)| < \frac{9}{7 \cdot 2^6} < 0.02$

A-6: $|f(0.1) - T_2(0.1)| < \frac{1}{1125}$

A-7: $\left| f\left(-\frac{1}{4}\right) - T_5\left(-\frac{1}{4}\right) \right| < \frac{1}{6 \cdot 4^6} < 0.00004$

A-8: Your answer may vary. One reasonable answer is

$|f(30) - T_3(30)| < \frac{14}{5^7 \cdot 9 \cdot 15} < 0.000002$. Another reasonable answer is

$|f(30) - T_3(30)| < \frac{14}{5^7 \cdot 9} < 0.00002$.

A-9: Equation 9.6.6 gives the bound $|f(0.01) - T_n(0.01)| \leq 100^2 \left(\frac{100}{\pi} - 1\right)^2$.

A more reasonable bound on the error is that it is less than 5.

A-10: Using Equation 9.6.6,

$$\left| f\left(\frac{1}{2}\right) - T_2\left(\frac{1}{2}\right) \right| < \frac{1}{10}.$$

The actual error is

$$\left| f\left(\frac{1}{2}\right) - T_2\left(\frac{1}{2}\right) \right| = \frac{\pi}{6} - \frac{1}{2}$$

which is about 0.02.

A-11: Any n greater than or equal to 3.

A-12: $\sqrt[7]{2200} \approx 3 + \frac{13}{7 \cdot 3^6} \approx 3.00255$

A-13: If we're going to use Equation 9.6.6, then we'll probably be taking a Taylor polynomial. Using Example 9.5.5, the 6th-degree Maclaurin polynomial for $\sin x$ is

$$T_6(x) = T_5(x) = x - \frac{x^3}{3!} + \frac{x^5}{5!}$$

so let's play with this a bit. Equation 9.6.6 tells us that the error will depend on the seventh derivative of $f(x)$, which is $-\cos x$:

$$\begin{aligned} f(1) - T_6(1) &= f^{(7)}(c) \frac{1^7}{7!} \\ \sin(1) - \left(1 - \frac{1}{3!} + \frac{1}{5!}\right) &= \frac{-\cos c}{7!} \\ \sin(1) - \frac{101}{5!} &= \frac{-\cos c}{7!} \\ \sin(1) &= \frac{4242 - \cos c}{7!} \end{aligned}$$

for some c between 0 and 1. Since $-1 \leq \cos c \leq 1$,

$$\begin{aligned} \frac{4242 - 1}{7!} &\leq \sin(1) \leq \frac{4242 + 1}{7!} \\ \frac{4241}{7!} &\leq \sin(1) \leq \frac{4243}{7!} \\ \frac{4241}{5040} &\leq \sin(1) \leq \frac{4243}{5040} \end{aligned}$$

Remark: there are lots of ways to play with this idea to get better estimates. One way is to take a higher-degree Maclaurin polynomial. Another is to note that, since $0 < c < 1 < \frac{\pi}{3}$, then

$\frac{1}{2} < \cos c < 1$, so

$$\begin{aligned} \frac{4242 - 1}{7!} &< \sin(1) < \frac{4242 - \frac{1}{2}}{7!} \\ \frac{4241}{5040} &< \sin(1) < \frac{8483}{10080} < \frac{4243}{5040} \end{aligned}$$

If you got tighter bounds than asked for in the problem, congratulations!

A-14: (a) $T_4(x) = \sum_{n=0}^4 \frac{x^n}{n!}$ (b) $T_4(1) = \frac{65}{24}$ (c) See the solution.

Answers to Exercises 10 — Jump to [TABLE OF CONTENTS](#)

A-1: The root is approximately $3 + \frac{1}{6} - \frac{(3 + \frac{1}{6})^2 - 10}{6 + \frac{1}{3}}$.

A-2: The root is approximately $\frac{28}{9}$.

A calculator tells us $(\frac{28}{9}) \approx 30.11$. This is pretty close to 30, which is the cube of the real root, so our approximation seems reasonable.

A-3: If we start with $x = 1$, we find the critical point is approximately $\frac{2}{5} = 0.4$.

A-4: Two reasonable answers are below.

- Starting with $x_0 = 11$ would give us an approximate intersection point of

$$x_1 = 11 + \frac{122(\arctan 11 - 1)}{121}.$$

- Starting with $x_0 = 10$ would give us an approximate intersection point of

$$x_1 = 10 + \frac{101(\arctan 10)}{100}.$$

A-5:

- Starting with $x = 1$:

$$\begin{aligned} x_0 &= 1 \\ x_1 &= 1 - \frac{1}{3} \cdot \frac{1 - 12 + 15}{1 - 4} = \frac{13}{9} \\ x_2 &= \frac{13}{9} - \frac{1}{3} \cdot \frac{\left(\frac{13}{9}\right)^3 - 12\left(\frac{13}{9}\right) + 15}{\left(\frac{13}{9}\right)^2 - 4} \end{aligned}$$

- Starting with $x = 3$:

$$\begin{aligned} x_0 &= 3 \\ x_1 &= 3 - \frac{1}{3} \cdot \frac{27 - 36 + 15}{9 - 4} = \frac{13}{5} \\ x_2 &= \frac{13}{5} - \frac{1}{3} \cdot \frac{\left(\frac{13}{5}\right)^3 - 12 \cdot \frac{13}{5} + 15}{\left(\frac{13}{5}\right)^2 - 4} \end{aligned}$$

A-6: Using the most obvious choices (that is: $f(x) = x^2 - 8$ and $x_0 = 3$), we approximate $\sqrt{8} \approx 3 - \frac{1}{6}$.

A-7: $\approx \frac{1}{3} - \frac{1}{90}$

A-8: $\approx \frac{5}{6}$

A-9: $\sqrt[3]{0.065} \approx 0.4 + \frac{1}{480}$

$\sqrt[3]{215} \approx 6 - \frac{1}{108}$

Answers to Exercises 11 — Jump to [TABLE OF CONTENTS](#)

A-1: It takes $2 \log 2 \approx 1.39$ hours for half of the bacteria to die, and $2 \log 100 \approx 9.2$ hours for 99% of them to die.

A-3:

(a) C any value, $k = -5$

(b) C any value, $k = 3$

A-5:

(a) $y(t) = Ce^{-t}$;

(b) $c(x) = 20e^{-0.1x}$;

(c) $z(t) = 5e^{3t}$.

A-6:

(a) $\frac{dN}{dt} = 0.05N$

(b) $N(0) = 250$

(c) $N(t) = 250e^{0.05t}$

(d) 2.1×10^{10} rodents

A-7: The population $y(t)$ after t hours satisfies

$$\frac{dy}{dt} = ky, \quad y(0) = 1, \quad y\left(\frac{1}{3}\right) = 2y(0)$$

for some constant k .

The solution to this initial value problem is

$$y(t) = e^{3 \log 2 t} = 2^{3t}.$$

A-9:

(a) $P(5) = 1000e^{0.35} \approx 1419$

(b) $t = \frac{\log 2}{0.07} \approx 9.9$ years

A-10:

(a) $\frac{dy}{dt} = \left(\frac{\log 2}{0.27}\right)y$

(b) $\frac{dy}{dt} = \left(-\frac{\log 2}{0.1}\right)y$

A-11:

(a) $7500\sqrt{3} \approx 12990$

(b) $\frac{160,000}{3^{1.5}} \approx 30792$ bacteria

A-12:

(a) y_1 growing, y_2 declining

(b) y_1 has doubling time $\frac{\log 2}{0.2} \approx 3.5$ years; y_2 has half-life $\frac{\log 2}{0.3} \approx 2.3$ years

(c) $y_1(t) = 100e^{0.2t}$, $y_2(t) = 10000e^{-0.3t}$

(d) $2 \log 100 \approx 9.2$ years

A-13:

(a) 6246400000000 people (6.2464×10^{12})

(b) $3904\pi \approx 12265$ people per square km

A-14: $\frac{10}{3} \log 8 \approx 6.93$ years

A-15:

(a) 1 hour

(b) $r = \log(2)$

(c) 0.25 M

(d) $t = \log_2(10) \approx 3.322$ hours

A-16:

(a) 20 min

(b) $20 \log_2(10) \approx 66.44$ min

A-17: $\tau = \frac{\log(2)}{\log(10)}$

A-18:

(a) $\frac{5730 \log(10000)}{\log(2)} \approx 57100$ years

(b) 22920 years

A-19:

(a) 29 years

(b) 58 years

(c) $\frac{29 \log(800)}{\log(2)} \approx 279.7$ years

A-20: $\frac{5.3 \log 5}{\log 2} \approx 12.3$ years

A-21: $2e^{-8/50} \approx 1.7043$ kg

A-22: $y = 760 \left(\frac{675}{760}\right)^{3/5} \approx 707.8$ torr

Answers to Exercises 12 — Jump to [TABLE OF CONTENTS](#)

	k	t_k	y_k	actual value of $y(t_k)$
A-1:	0	0	100.00	100
	1	0.1	95.00	$100e^{-0.05} \approx 95.12$
	2	0.2	90.25	$100e^{-0.1} \approx 90.48$

A-2:

(a) $y_5 = 1.61051$; $y(0.5) = 1.6487213$; error = 0.03821

(b) $y_5 = 0.59049$; $y(0.5) = 0.60653$; error = 0.01604

A-4: Until $t = \frac{2\sqrt{h_0}}{k}$.

A-10:

(a) $C = -12$

(b) $C_1 = 1, C_2 = -5$

(c) For any integer n , we can have $C_2 = \pi n$, and $C_1 = \begin{cases} 1 & \text{if } n \text{ odd} \\ -1 & \text{if } n \text{ even} \end{cases}$. So for example, one option is $C_1 = -1, C_2 = 0$; another option is $C_1 = 1$ and $C_2 = \pi$.

A-12: (b) $k = 3/2$.

A-13:

(a) Input rate is I fish per day

(b) αF fish caught per fisher per day.

(c) Birth and mortality are neglected, or assumed to exactly cancel out.

(d) Steady state level $F = I/\alpha N$

(e) New differential equation is $\frac{dF}{dt} = -\alpha NF$; it would take $2\log(2)/\alpha N$ days for the population to fall to 25% of its initial level.

(f) New differential equation is $\frac{dF}{dt} = I$; it would take $t = F_{low}/I$ days to double.

A-15: The initial value problem is $\frac{dG}{dt} = \frac{5}{2} - \frac{G}{100}$, $G(0) = 0$. After a long time, there is 250 gm of glucose in the tank.

A-16:

(a) $Q'(t) = kr - \frac{Q}{V}r = -\frac{r}{V}[Q - kV]$;

(b) $Q = kV$;

(c) $T = V \ln 2/r$.

A-17:

(a) $\frac{dQ}{dt} = kQ$; $Q(t) = 100 \cdot 0.7^{t/4}$

(b) $\frac{-4 \log 2}{\log(0.7)} \approx 7.77$ hr. Note you should be able to get the exact value without the use of a calculator.

A-18:

(a) not provided

(b) y_0

(c) $t = \frac{2A\sqrt{y_0}}{k}$

(d) $-k\sqrt{y_0}$

A-19: $a = 0, b = -1$

A-20:

- Using $\Delta t = 0.5$, $y(0.5) \approx -0.5$.
- Using $\Delta t = 0.25$, $y(0.5) \approx -0.4705882353$.
- Using $\Delta t = 0.1$, $y(0.5) \approx -0.450264102$.

A-21: $y(0.03) \approx -0.000301$

A-22: $y(0.03) \approx 0.000301$

A-23: $y(0.03) \approx 1.00029998$

A-24: $y(1) \approx \frac{1}{2\sqrt{2}}$

A-25: $y(1) \approx 0$ (actually: $y(1) = 0$)

A-26: $y(3) \approx \frac{3}{2} + \frac{1}{2} \cdot \sqrt{\frac{3}{2}}$

A-27: $y(1.5) \approx \frac{15}{77} \approx 0.1948051948$ (actually, the value is exact)

Answers to Exercises 13 — Jump to [TABLE OF CONTENTS](#)

A-1:

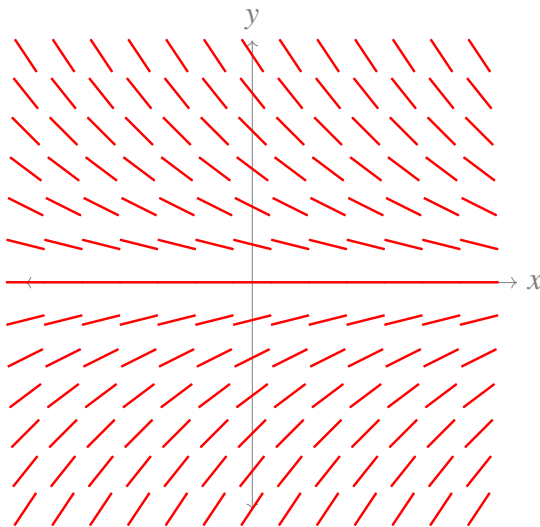

(a)

Steady state: $y = 0$. If $y(0) = 1$, $y \rightarrow 0$.

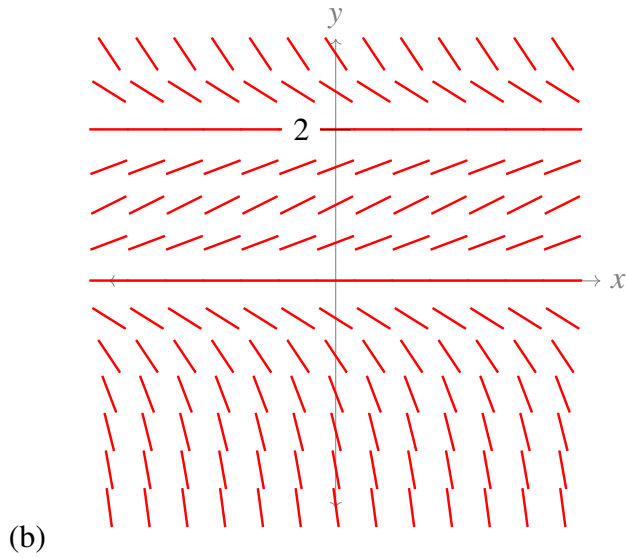

Steady states: $y = 0, 2$. If $y(0) = 1$, $y \rightarrow 2$.

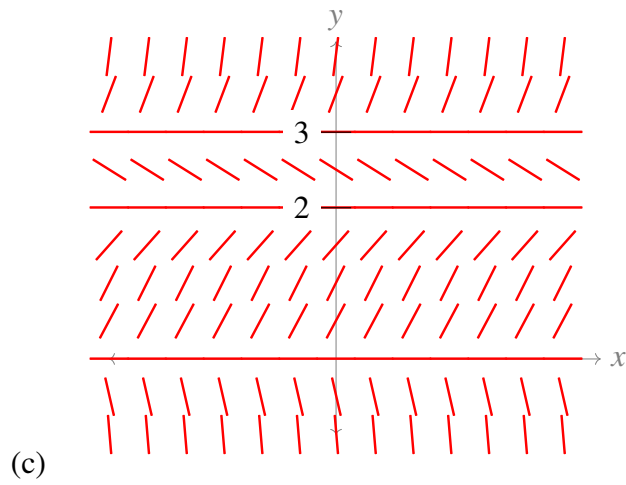

Steady states: $y = 0, 2, 3$. If $y(0) = 1$, $y \rightarrow 2$.

A-2:

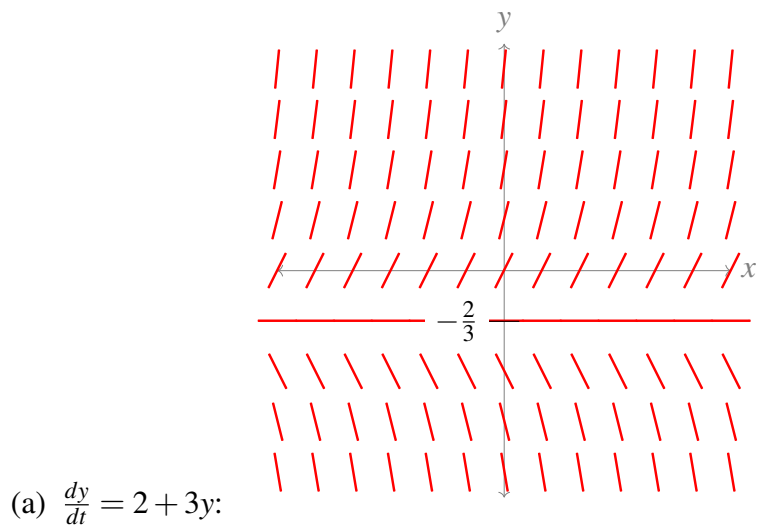

(b) $\frac{dy}{dt} = -y(2-y)$:

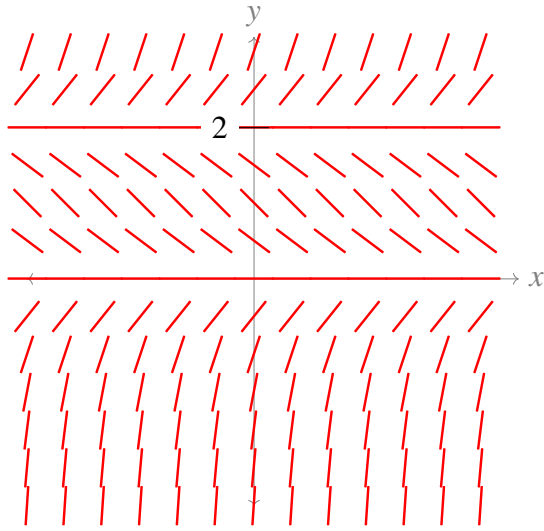

(c) $\frac{dy}{dt} = 2 - 3y + y^2$:

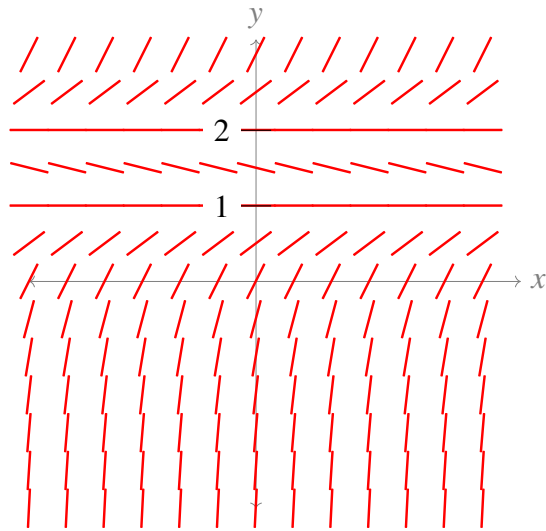

(d) $\frac{dy}{dt} = -2(3-y)^2$:

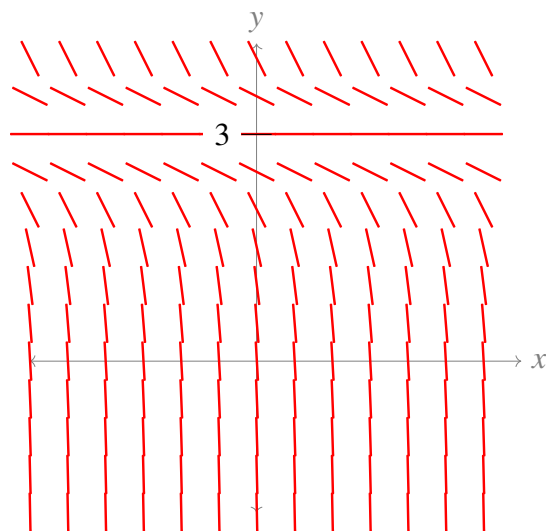

(e) $\frac{dy}{dt} = y^2 - y + 1$:

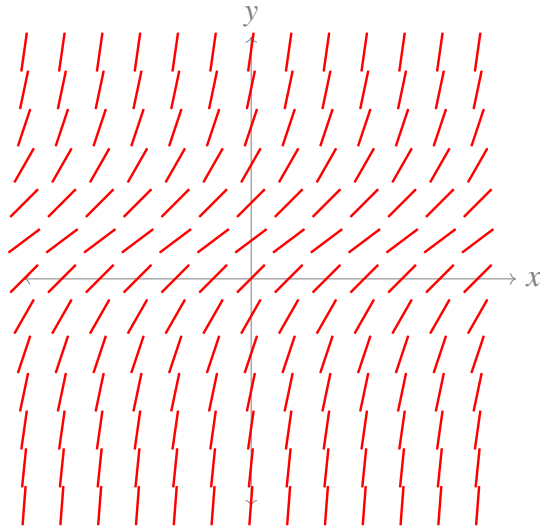

(f) $\frac{dy}{dt} = y^3 - y$:

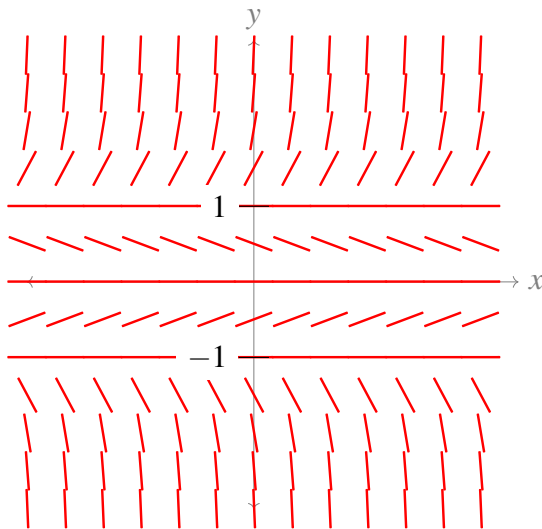

(g) $\frac{dy}{dt} = \sqrt{y}(y-2)(y-3)^2, y \geq 0$:

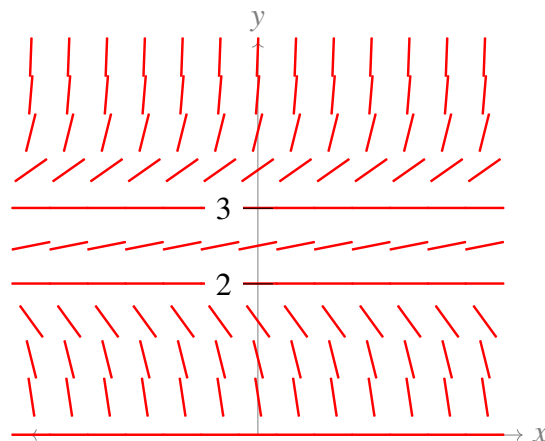

A-3:

(a) $\frac{dy}{dt} = 2 + 3y$:

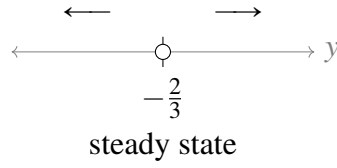
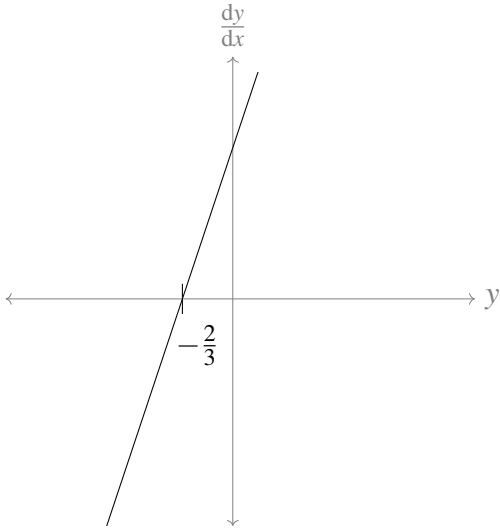

(b) $\frac{dy}{dt} = -y(2-y)$:

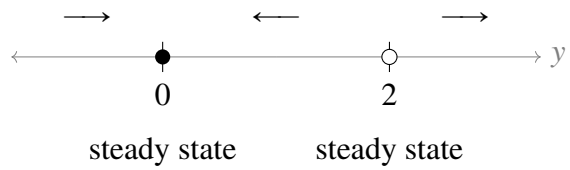
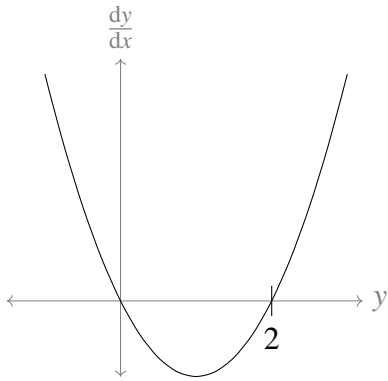

(c) $\frac{dy}{dt} = 2 - 3y + y^2$:

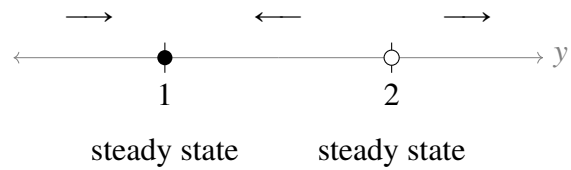
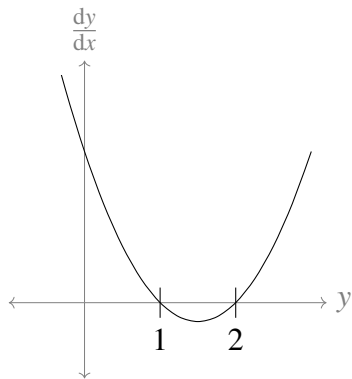

(d) $\frac{dy}{dt} = -2(3-y)^2$:

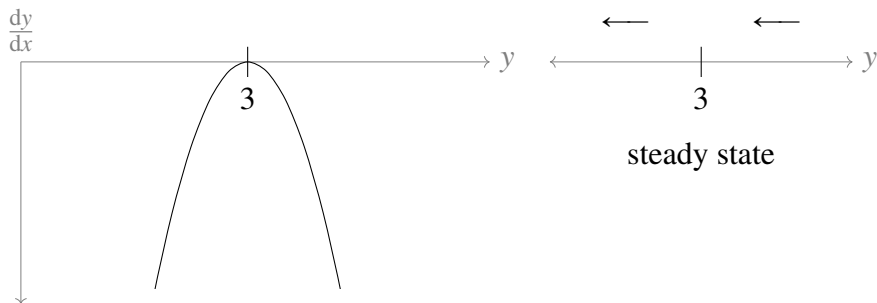

(e) $\frac{dy}{dt} = y^2 - y + 1$:

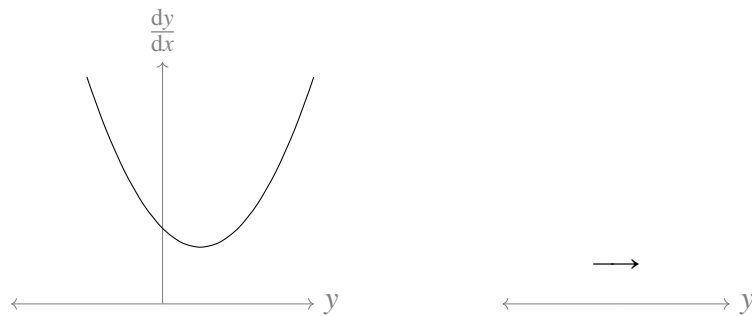

(f) $\frac{dy}{dt} = y^3 - y$:

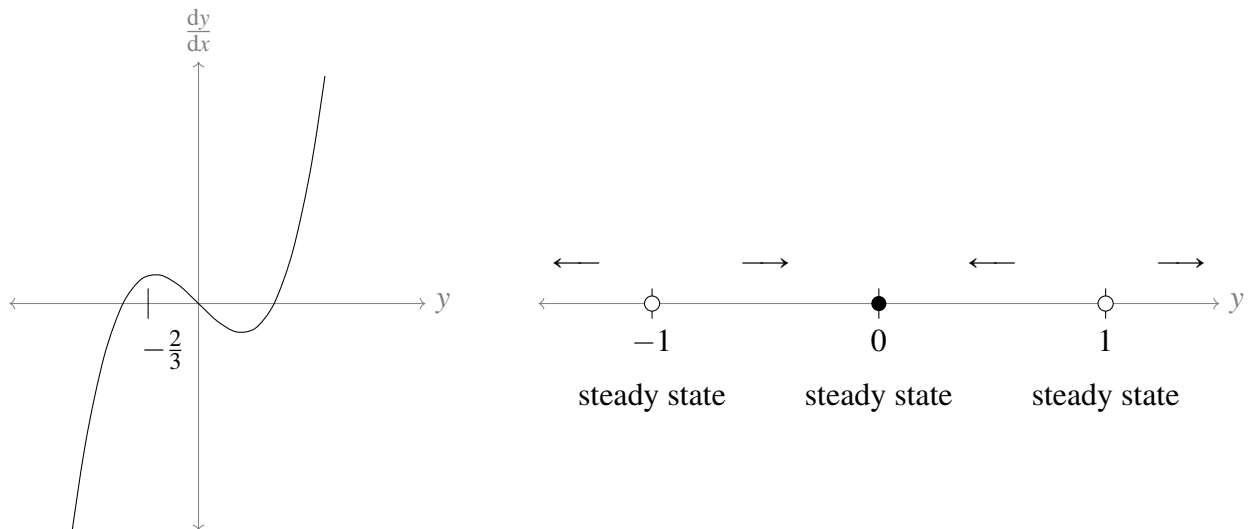

(g) $\frac{dy}{dt} = \sqrt{y}(y-2)(y-3)^2, y \geq 0$:

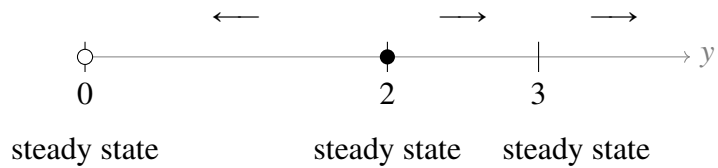
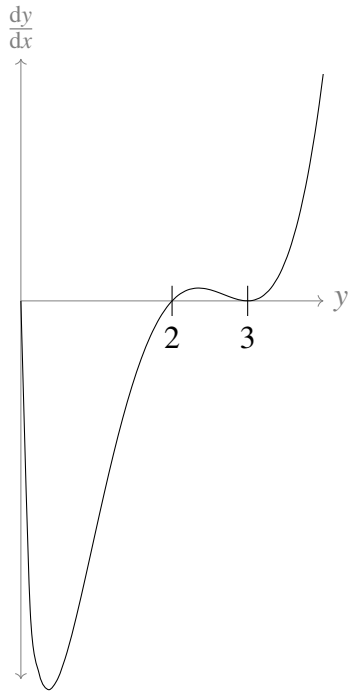

A-4: (B)

A-5: (B)

A-6: $h(t) \rightarrow (I/K)^2$

A-7: (a) $\frac{dx}{dt} = \frac{k}{3}(V_0 - x^3)$; (d) $V = \frac{1}{2}V_0$.

A-9:

(a) $K_{\max}, c = k$

(b) $\ln(2)/r$

(c) $c = 0, c = \frac{K_{\max}}{r} - k$

A-12: $\frac{dy}{ds} = y(1 - y)$

A-14: (c) Steady states at $y_2 = 0$ and $y_2 = P - b/a$. (d) Social media persists if $Pa/b > 1$.

A-15: (b) Stable steady state at $a = \frac{\beta}{2\mu} \left(-1 + \sqrt{1 + 4\mu M/\beta} \right)$

Answers to Exercises 14.1 — Jump to [TABLE OF CONTENTS](#)

A-1:

The xz plane is filled with vertical lines; the yz plane is crosshatched; and the xy plane is solid.

The left bottom triangle vertex is $(1,0,0)$; the right bottom triangle vertex is $(0,1,0)$; the top triangle vertex is $(0,0,1)$.

A-2: (a) The sphere of radius 3 centered on $(1, -2, 0)$.

(b) The interior of the sphere of radius 3 centered on $(1, -2, 0)$.

A-3: (a) $x = y$ is the straight line through the origin that makes an angle 45° with the x - and y -axes. It is sketched in the figure on the left below.

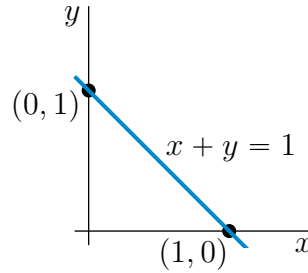
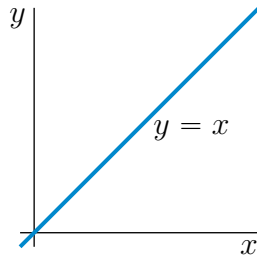

(b) $x + y = 1$ is the straight line through the points $(1,0)$ and $(0,1)$. It is sketched in the figure on the right above.

(c) $x^2 + y^2 = 4$ is the circle with centre $(0,0)$ and radius 2. It is sketched in the figure on the left below.

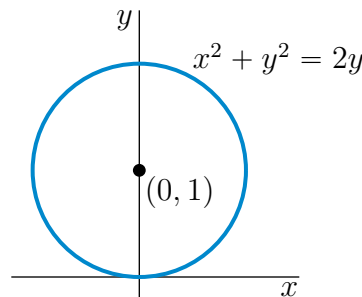
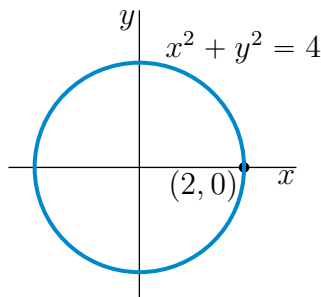

(d) $x^2 + y^2 = 2y$ is the circle with centre $(0,1)$ and radius 1. It is sketched in the figure on the right above.

(e) $x^2 + y^2 < 2y$ is the set of points that are strictly inside the circle with centre $(0,1)$ and radius 1. It is the shaded region (not including the dashed circle) in the sketch below.

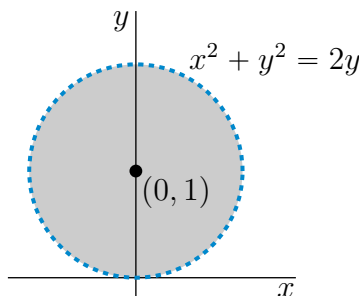

A-4: (a) The set $z = x$ is the plane which contains the y -axis and which makes an angle 45° with the xy -plane. Here is a sketch of the part of the plane that is in the first octant.

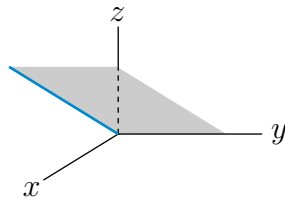

(b) $x^2 + y^2 + z^2 = 4$ is the sphere with centre $(0,0,0)$ and radius 2. Here is a sketch of the part of the sphere that is in the first octant.

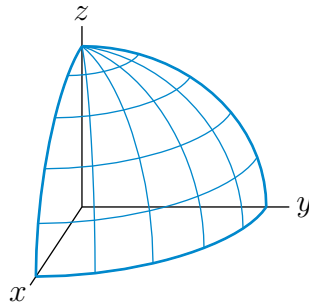

(c) $x^2 + y^2 + z^2 = 4, z = 1$ is the circle in the plane $z = 1$ that has centre $(0,0,1)$ and radius $\sqrt{3}$. The part of the circle in the first octant is the heavy quarter circle in the sketch

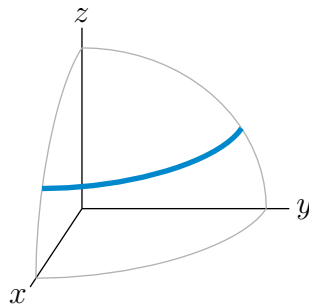

(d) $x^2 + y^2 = 4$ is the cylinder of radius 2 centered on the z -axis. Here is a sketch of the part of the cylinder that is in the first octant.

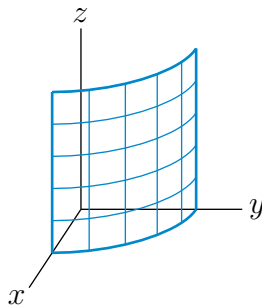

(e) $z = x^2 + y^2$ is a paraboloid consisting of a vertical stack of horizontal circles. The intersection of the surface with the yz -plane is the parabola $z = y^2$. Here is a sketch of the part of the paraboloid that is in the first octant.

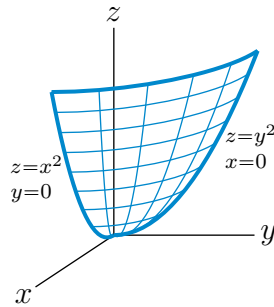

A-5: $\sqrt{67}$

A-6: 9

A-7: $\sqrt{5.01}$ km

A-8: 1 km

A-9: 2 km

A-10:

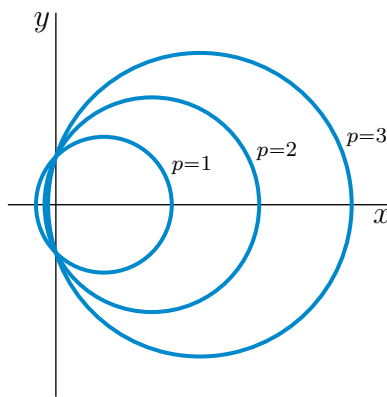

A-11: The sphere has radius 3 and is centered on $(1, 2, -1)$.

A-12: The circumscribing circle has centre (\bar{x}, \bar{y}) and radius r with $\bar{x} = \frac{a}{2}$, $\bar{y} = \frac{b^2+c^2-ab}{2c}$ and $r = \sqrt{\left(\frac{a}{2}\right)^2 + \left(\frac{b^2+c^2-ab}{2c}\right)^2}$.

A-13: $x^2 + y^2 = 4z$ The surface is a paraboloid consisting of a stack of horizontal circles, starting with a point at the origin and with radius increasing vertically. The circle in the plane $z = z_0$ has radius $2\sqrt{z_0}$.

Answers to Exercises 14.2 — Jump to [TABLE OF CONTENTS](#)

A-1: Any constant function, for example $f(x, y) = 0$.

A-2:

(a) $[-10, 10]$

(b) $[0, 1]$

(c) $[-1, 1]$

(d) $[0, 10]$

A-3: yes

A-4: Domain: all of \mathbb{R}^2 . Range: $[0, \infty)$

A-5: Domain: all of \mathbb{R}^2 . Range: $[0, \infty)$.

A-6: Domain: interior of the unit circle. Range: $[0, \pi/2]$.

A-7: Domain: all points (x, y) such that x and y have the same sign; x and y are nonzero; and $y \neq \frac{1}{x}$.

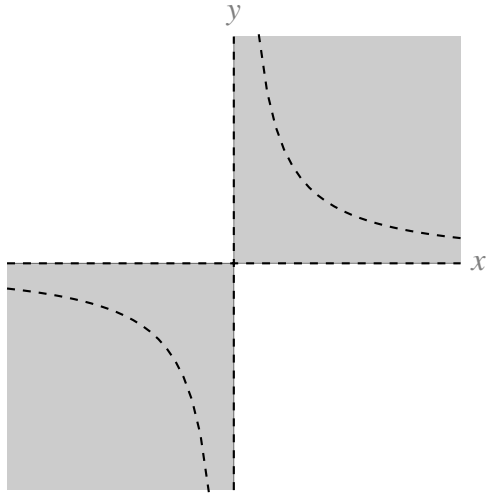

Range: $(-\infty, 0) \cup (0, \infty)$.

A-8: Domain: all of \mathbb{R}^2 . Range: $[0, 1)$.

A-9: Domain: all of \mathbb{R}^2 . Range: $[-\frac{3}{2}, \frac{3}{2}]$.

A-10: For example: domain should be all (a, p) where $a \geq 0$ and $p > 0$; range should be $[0, \infty)$.

A-11: $\frac{1}{5} \leq x^2 + y^2 \leq \frac{1}{3}$: that is, the points (x, y) that are inside or on the circle centred at the origin with radius $\frac{1}{\sqrt{3}}$, but not inside the circle centred at the origin with radius $\frac{1}{\sqrt{5}}$.

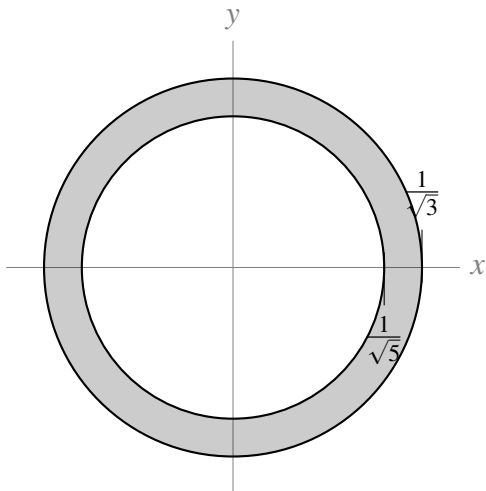

A-12:

The point (x, y) must be in one of the following regions:

- $x^2 - \sqrt{68} \leq y \leq x^2 - \sqrt{47}$
- $x^2 - 5 \leq y \leq x^2 - 2$
- $x^2 + 2 \leq y \leq x^2 + 5$
- $x^2 + \sqrt{47} \leq y \leq x^2 + \sqrt{68}$

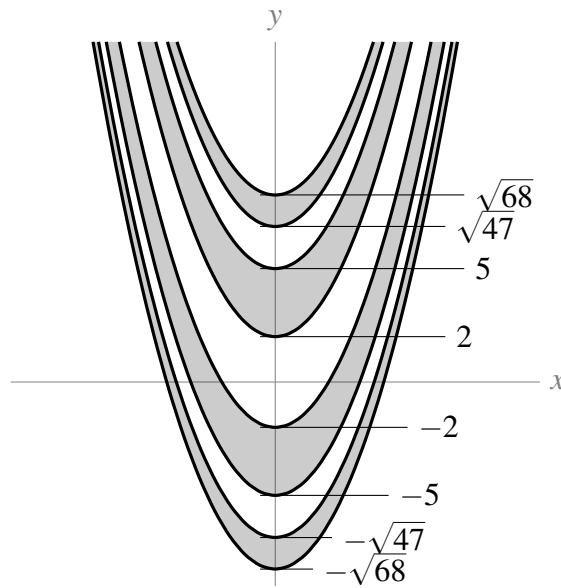

Answers to Exercises 14.3 — Jump to [TABLE OF CONTENTS](#)

A-1: (a) ↔ (B) (b) ↔ (A) (c) ↔ (C)

A-2:

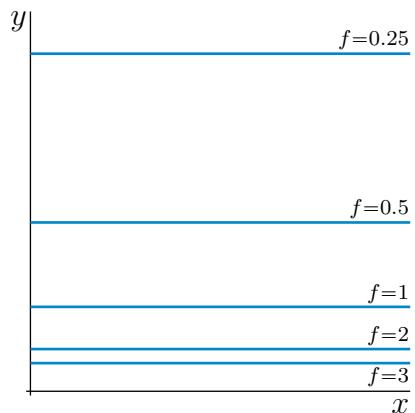

A-3: (a)

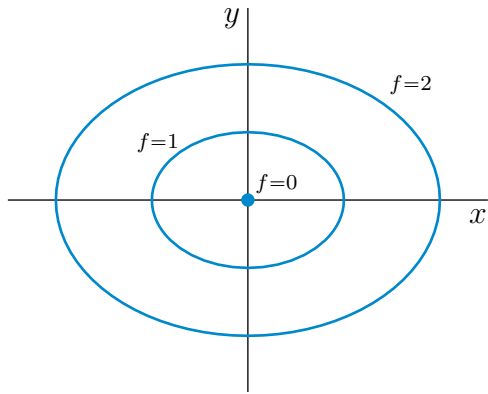

(b)

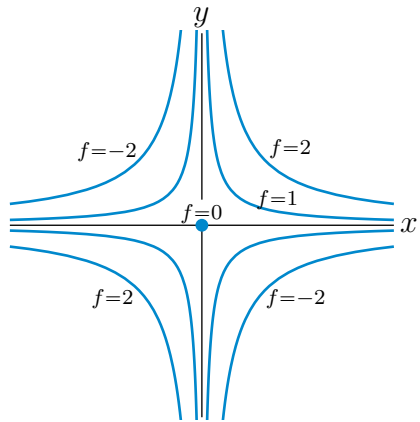

(c)

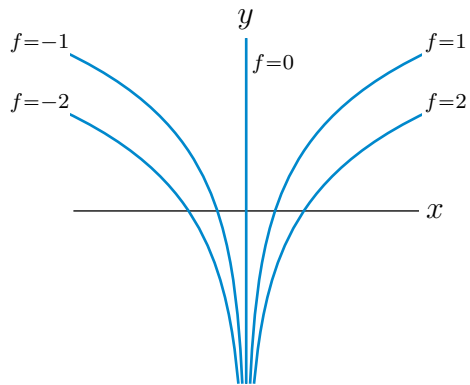

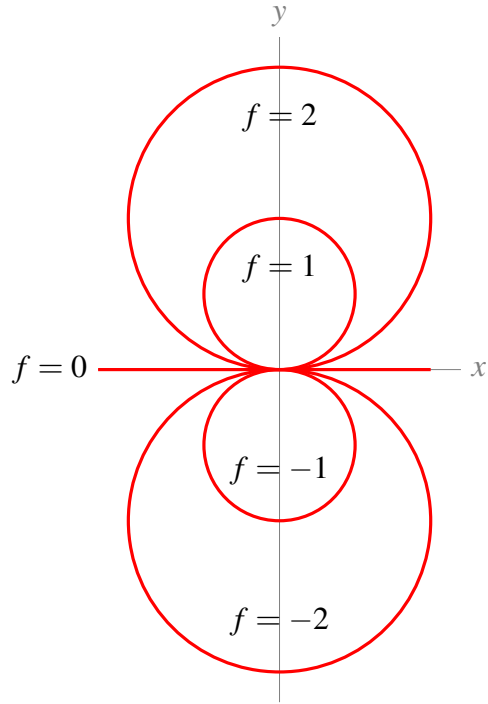

A-5: (a)

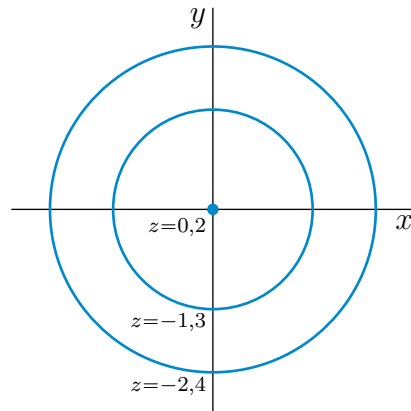

(b)

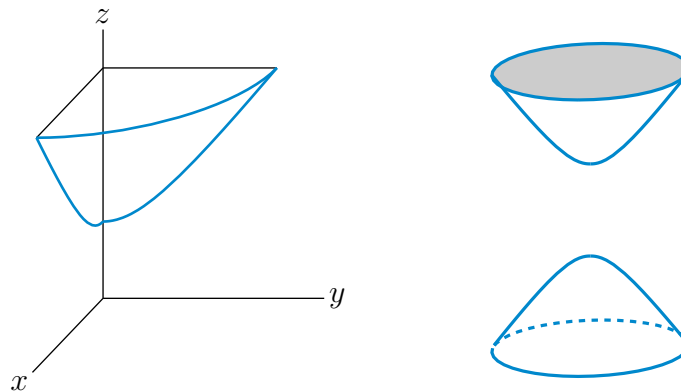

A-6:

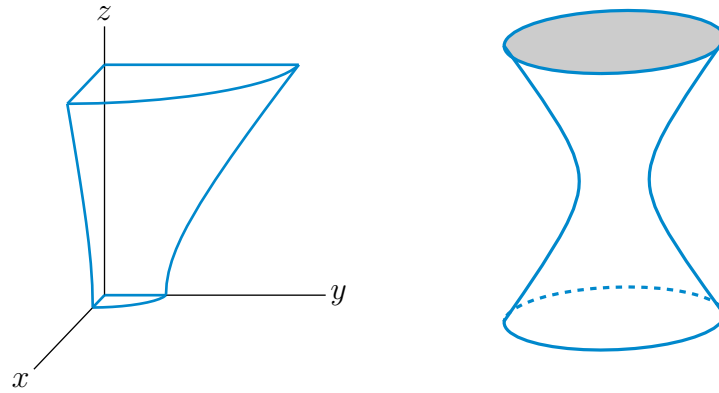

A-7: (a)

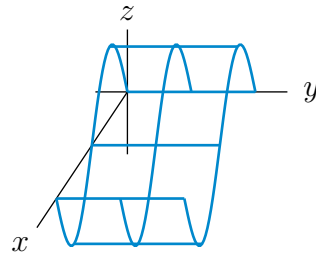

(b)

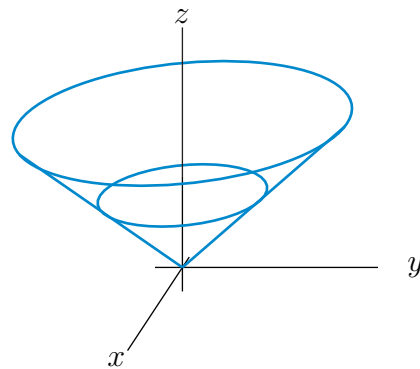

(c)

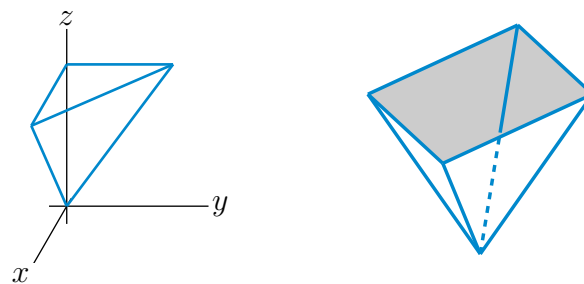

A-8: (a) This is an elliptic cylinder parallel to the z -axis. Here is a sketch of the part of the surface above the xy -plane.

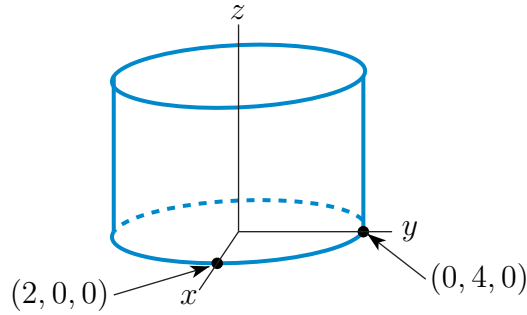

(b) This is a plane through $(4, 0, 0)$, $(0, 4, 0)$ and $(0, 0, 2)$. Here is a sketch of the part of the plane in the first octant.

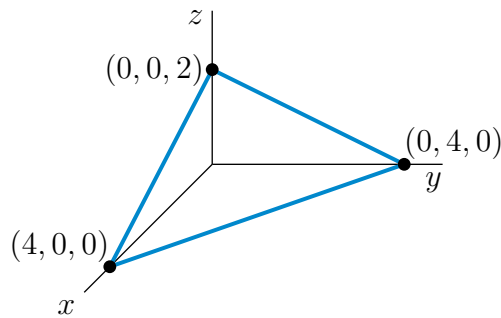

(c) This is a hyperboloid of one sheet with axis the x -axis.

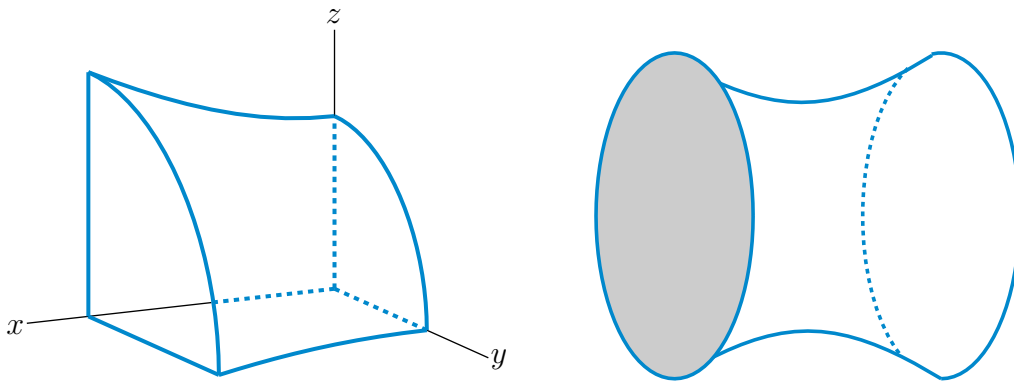

(d) This is a circular cone centred on the y -axis.

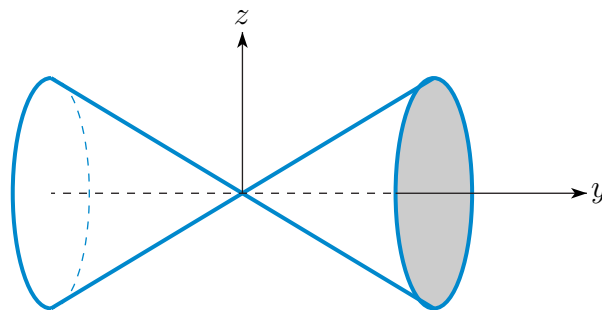

(e) This is an ellipsoid centered on the origin with semiaxes 3 , $\sqrt{12} = 2\sqrt{3}$ and 3 along the x , y and z -axes, respectively.

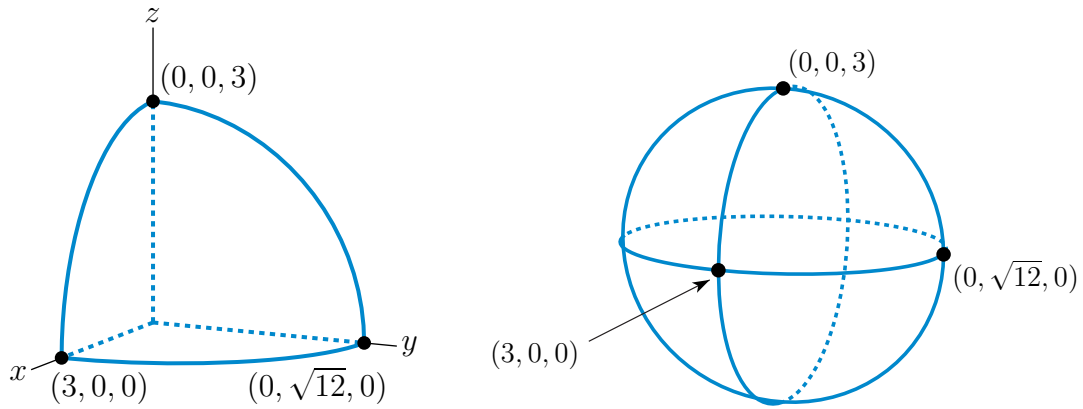

(f) This is a sphere of radius $r_b = \frac{1}{2}\sqrt{b^2 + 4b + 97}$ centered on $\frac{1}{2}(-4, b, -9)$.

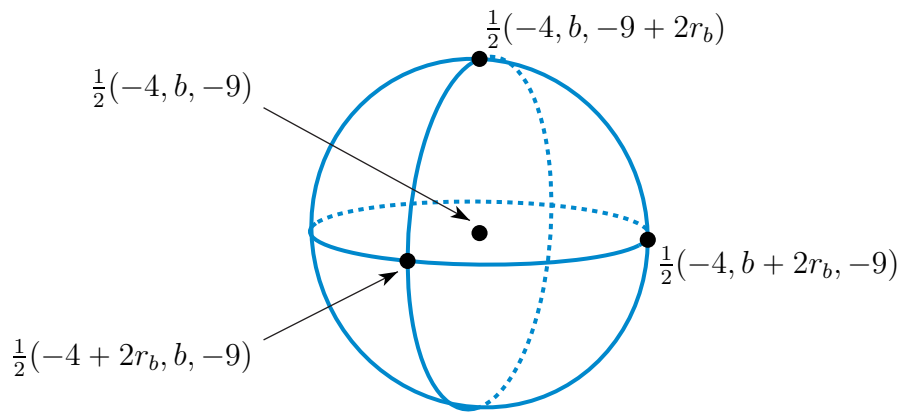

(g) This is an elliptic paraboloid with axis the x -axis.

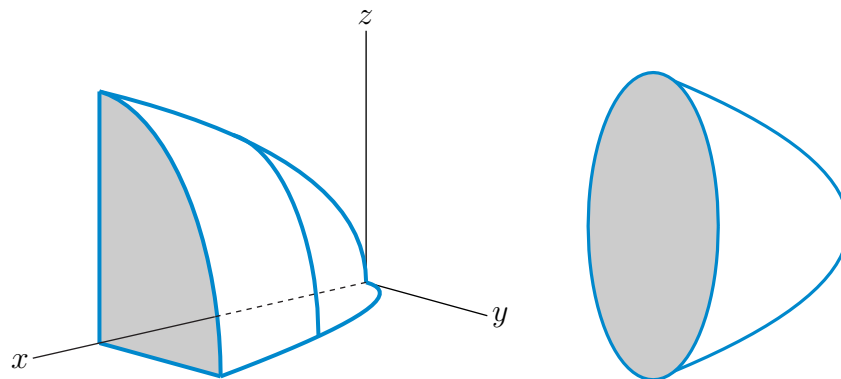

(h) This is an upward opening parabolic cylinder.

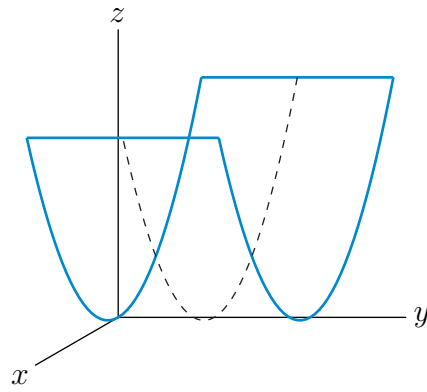

A-9: $z = 0$:

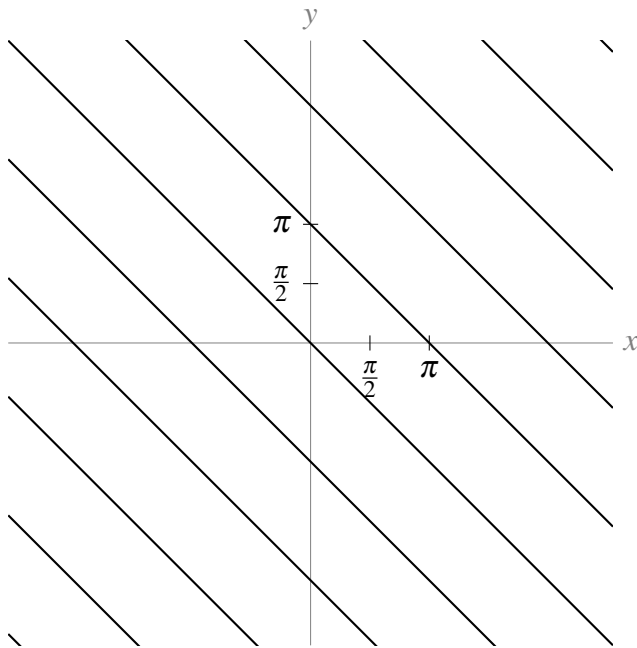

$z = 1$:

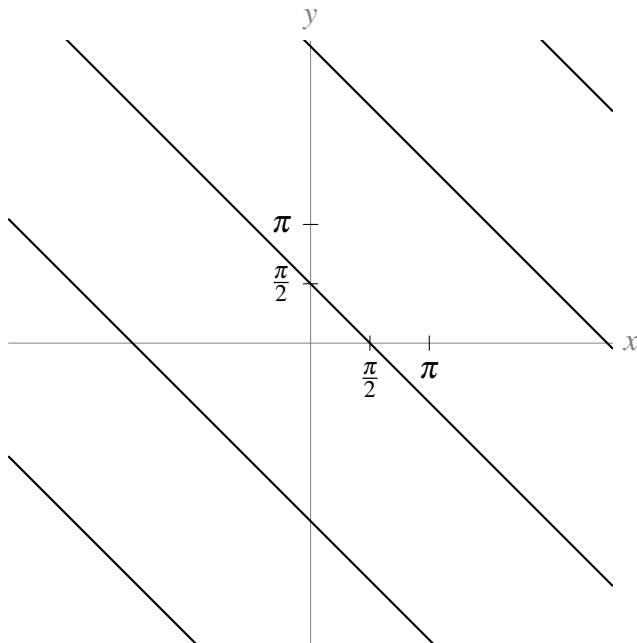

$z = 2$:

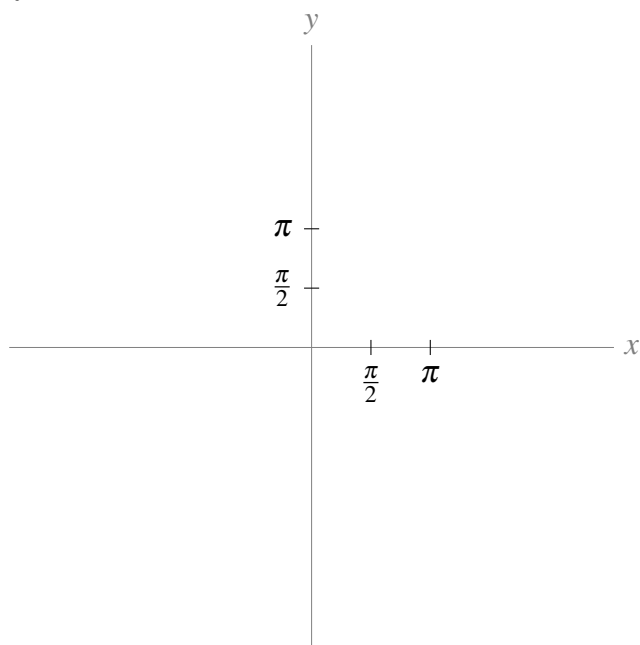

A-10: $x^2 + y^2 = \left(\frac{|z|}{3} + 1\right)^2$

Answers to Exercises 15.1 — Jump to [TABLE OF CONTENTS](#)

A-1: No: you can go higher by moving in the negative y direction.

A-2:

(a) $f_y(1.5, 2.4) \approx -2$

(b) $f_x(1.7, 1.7) \approx 11$

(c) $f_y(1.7, 1.7) \approx -3$

(d) $f_x(1.1, 2) \approx 9$

A-3: (a)

$$f_x(x, y, z) = 3x^2y^4z^5$$

$$f_y(x, y, z) = 4x^3y^3z^5$$

$$f_z(x, y, z) = 5x^3y^4z^4$$

$$f_x(0, -1, -1) = 0$$

$$f_y(0, -1, -1) = 0$$

$$f_z(0, -1, -1) = 0$$

(b)

$$w_x(x, y, z) = \frac{yze^{xyz}}{1 + e^{xyz}}$$

$$w_y(x, y, z) = \frac{xze^{xyz}}{1 + e^{xyz}}$$

$$w_z(x, y, z) = \frac{xye^{xyz}}{1 + e^{xyz}}$$

$$w_x(2, 0, -1) = 0$$

$$w_y(2, 0, -1) = -1$$

$$w_z(2, 0, -1) = 0$$

(c)

$$\begin{aligned}f_x(x,y) &= -\frac{x}{(x^2+y^2)^{3/2}} & f_x(-3,4) &= \frac{3}{125} \\f_y(x,y) &= -\frac{y}{(x^2+y^2)^{3/2}} & f_y(-3,4) &= -\frac{4}{125}\end{aligned}$$

A-4: By the quotient rule

$$\begin{aligned}\frac{\partial z}{\partial x}(x,y) &= \frac{(1)(x-y) - (x+y)(1)}{(x-y)^2} = \frac{-2y}{(x-y)^2} \\ \frac{\partial z}{\partial y}(x,y) &= \frac{(1)(x-y) - (x+y)(-1)}{(x-y)^2} = \frac{2x}{(x-y)^2}\end{aligned}$$

Hence

$$x \frac{\partial z}{\partial x}(x,y) + y \frac{\partial z}{\partial y}(x,y) = \frac{-2xy + 2yx}{(x-y)^2} = 0$$

A-5: (a) $\frac{\partial z}{\partial x} = \frac{z(1-x)}{x(yz-1)}$, $\frac{\partial z}{\partial y} = \frac{z(1+y-yz)}{y(yz-1)}$

(b) $\frac{\partial z}{\partial x}(-1,-2) = \frac{1}{2}$, $\frac{\partial z}{\partial y}(-1,-2) = 0$.

A-6: $\frac{\partial U}{\partial T}(1,2,4) = -\frac{2\log(2)}{1+2\log(2)}$ $\frac{\partial T}{\partial V}(1,2,4) = 1 - \frac{1}{4\log(2)}$

A-7: 24

A-8: $f_x(0,0) = 1$, $f_y(0,0) = 2$

A-9: Yes.

A-10: (a) $\frac{\partial f}{\partial x}(0,0) = 1$, $\frac{\partial f}{\partial y}(0,0) = 4$ (b) Nope.

A-11: 1 resp. 0

A-12: (a) 0 (b) 0 (c) $\frac{1}{2}$

Answers to Exercises 15.2 — Jump to [TABLE OF CONTENTS](#)

A-1: From the example that “ f_x ” is the partial derivative of f with respect to x , we infer that the notation for “take the partial derivative with respect to (variable)” is “write (variable) on the bottom right.” Continuing this practice, to take the partial derivative with respect to y of f_x , we should write the y on the bottom right – that is, to the right of the x :

$$(f_x)_y$$

Since x is to the left of y , we write the above as f_{xy} , not f_{yx} .

A-2: From the example that “ $\frac{\partial}{\partial x}f$ ” is the partial derivative of f with respect to x , we infer that the notation for “take the partial derivative of a function with respect to (variable)” is “put the partial

derivative operator $\frac{\partial}{\partial(\text{variable})}$ to the left of the function.” Continuing this practice, to take the partial derivative with respect to y of $\frac{\partial f}{\partial x}$, we should write the operator $\frac{\partial}{\partial y}$ on the left.

$$\frac{\partial}{\partial y} \left[\frac{\partial}{\partial x} f \right]$$

In the above expression, ∂y is to the left of the ∂x . So we write $\frac{\partial^2 f}{\partial y \partial x}$ rather than $\frac{\partial^2 f}{\partial x \partial y}$.

A-3: As in Question 2, if we want to differentiate $\frac{\partial f}{\partial x}$ with respect to x , we write:

$$\frac{\partial}{\partial x} \left[\frac{\partial}{\partial x} f \right] \quad \text{or} \quad \frac{\partial}{\partial x} \left[\frac{\partial f}{\partial x} \right]$$

In both cases:

- f shows up only once, so we don't add an exponent to it.
- ∂ shows up twice in the numerator, so we write ∂^2 as shorthand for $\partial[\partial]$.
- ∂x shows up twice in the denominator, so we write ∂x^2 as shorthand for $\partial x[\partial x]$.

A-4: see solution

A-5: (a) $f_{xx}(x, y) = 2y^3$ $f_{yxy}(x, y) = f_{xyy}(x, y) = 12xy$

(b) $f_{xx}(x, y) = y^4 e^{xy^2}$ $f_{xy}(x, y) = (2y + 2xy^3) e^{xy^2}$ $f_{xxy}(x, y) = (4y^3 + 2xy^5) e^{xy^2}$
 $f_{xyy}(x, y) = (2 + 10xy^2 + 4x^2y^4) e^{xy^2}$

(c) $\frac{\partial^3 f}{\partial w \partial v \partial u}(u, v, w) = -\frac{36}{(u + 2v + 3w)^4}$ $\frac{\partial^3 f}{\partial w \partial v \partial u}(3, 2, 1) = -0.0036 = -\frac{9}{2500}$

A-6: $f_{xx} = \frac{5y^2}{(x^2+5y^2)^{3/2}}$ $f_{xy} = f_{yx} = -\frac{5xy}{(x^2+5y^2)^{3/2}}$ $f_{yy} = \frac{5x^2}{(x^2+5y^2)^{3/2}}$

A-7: (a) $f_{xyz}(x, y, z) = 0$ (b) $f_{xyz}(x, y, z) = 0$ (c) $f_{xx}(1, 0, 0) = 0$

A-8: See the solution.

A-9:

$$f_{xy}(1.8, 2.0) \approx 0$$

Answers to Exercises 16.1 — Jump to [TABLE OF CONTENTS](#)

A-1: (a) (i) T, U

(a) (ii) U

(a) (iii) S

(b) (i) $F_x(1, 2) > 0$

(b) (ii) F does *not* have a critical point at $(2, 2)$.

(b) (iii) $F_{xy}(1, 2) < 0$

A-2: (a)

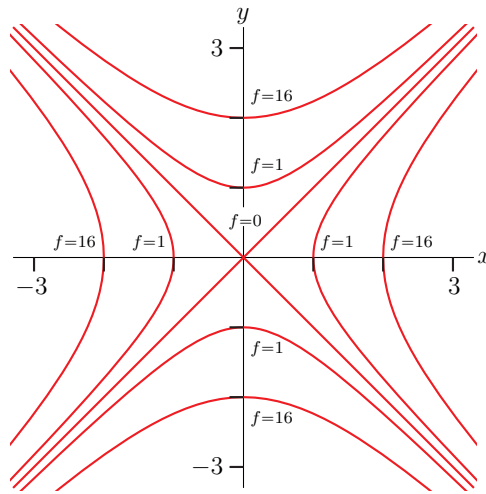

(b) $(0,0)$ is a local (and also absolute) minimum.

(c) No. See the solutions.

A-3: $|c| > 2$

	critical point	type
A-4:	$(0,0)$	saddle point
	$(-\frac{2}{3}, \frac{2}{3})$	local max

	critical point	type
A-5:	$(0,3)$	saddle point
	$(0,-3)$	saddle point
	$(-2,1)$	local max
	$(2,-1)$	local min

	critical point	type
A-6:	$(0,0)$	local min
	$(\sqrt{2}, -1)$	saddle point
	$(-\sqrt{2}, -1)$	saddle point

	critical point	type
A-7:	$(\frac{1}{\sqrt{3}}, \frac{1}{\sqrt{3}})$	local min
	$(-\frac{1}{\sqrt{3}}, \frac{1}{\sqrt{3}})$	saddle point

	critical point	type
A-8:	$(0,0)$	local max
	$(2,0)$	saddle point

A-9: (a)

critical point	type
$(\frac{3}{2}, -\frac{1}{4})$	local min
$(-1, 1)$	saddle point

(b)

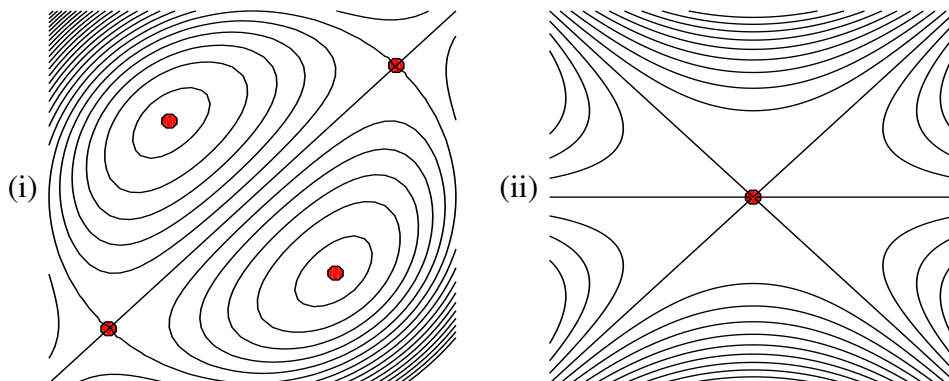

A-10:

critical point	type
$(\frac{3}{2}, -\frac{1}{4})$	local min
$(-1, 1)$	saddle point

A-11: $(0,0)$ is a local max

$(0,2)$ is a local min

$(1,1)$ and $(-1,1)$ are saddle points

A-12: $(0,0)$ is a saddle point and $\pm(1,1)$ are local mins

A-13: $(0,0)$ is a saddle point and $\pm(1,1)$ are local mins

A-14: $(0, \pm 1)$ are saddle points, $(\frac{1}{\sqrt{3}}, 0)$ is a local min and $(-\frac{1}{\sqrt{3}}, 0)$ is a local max

A-15: $(-1, \pm\sqrt{3})$ and $(2,0)$ are saddle points and $(0,0)$ is a local max.

A-16: Case $k < \frac{1}{2}$:

critical point	type
$(0,0)$	local max
$(0,2)$	saddle point

Case $k = \frac{1}{2}$:

critical point	type
$(0,0)$	local max
$(0,2)$	unknown

Case $k > \frac{1}{2}$:

critical point	type
(0, 0)	local max
(0, 2)	local min
$\left(\sqrt{\frac{1}{k^3}}(2k-1), \frac{1}{k}\right)$	saddle point
$\left(-\sqrt{\frac{1}{k^3}}(2k-1), \frac{1}{k}\right)$	saddle point

A-17: $m = \frac{nS_{xy} - S_x S_y}{nS_{x^2} - S_x^2}$ and $b = \frac{S_y S_{x^2} - S_x S_{xy}}{nS_{x^2} - S_x^2}$ where $S_y = \sum_{i=1}^n y_i$, $S_{x^2} = \sum_{i=1}^n x_i^2$ and $S_{xy} = \sum_{i=1}^n x_i y_i$.

Answers to Exercises 16.2 — Jump to TABLE OF CONTENTS

A-1: false

A-2: The minimum height is zero at (0, 0, 0). The derivatives z_x and z_y do not exist there. The maximum height is $\sqrt{2}$ at $(\pm 1, \pm 1, \sqrt{2})$. There z_x and z_y exist but are not zero — those points would not be the highest points if it were not for the restriction $|x|, |y| \leq 1$.

A-3: $\min = 0$ $\max = \frac{2}{3\sqrt{3}} \approx 0.385$

A-4: (a)

critical point	type
$\left(0, \frac{2}{\sqrt{3}}\right)$	local max
$\left(0, -\frac{2}{\sqrt{3}}\right)$	local min
(2, 0)	saddle point
(-2, 0)	saddle point

(b) The maximum and minimum values of $h(x, y)$ in $x^2 + y^2 \leq 1$ are 3 (at (0, 1)) and -3 (at (0, -1)), respectively.

A-5: The minimum is -2 and the maximum is 6.

A-6: $6 - 2\sqrt{5}$

A-7: (a) (0, 0) and (3, 0) and (0, 3) are saddle points
(1, 1) is a local min

(b) The minimum is -1 at (1, 1) and the maximum is 80 at (4, 4).

A-8: (a) (1, 1) is a saddle point and (2, 4) is a local min

(b) The min and max are $\frac{19}{27}$ and 5, respectively.

A-9: (a) (0, 0), (6, 0), (0, 3) are saddle points and (2, 1) is a local min

(b) The maximum value is 0 and the minimum value is $4(4\sqrt{2} - 6) \approx -1.37$.

A-10: The coldest temperature is -0.391 and the coldest point is (0, 2).

A-11: (a) (0, -5) is a saddle point

(b) The smallest value of g is 0 at $(0,0)$ and the largest value is 21 at $(\pm 2\sqrt{3}, -1)$.

A-12: $\frac{2500}{\sqrt{3}}$

A-13: The box has dimensions $(2V)^{1/3} \times (2V)^{1/3} \times 2^{-2/3}V^{1/3}$.

A-14: (a) The maximum and minimum values of $T(x,y)$ in $x^2 + y^2 \leq 4$ are 20 (at $(0,0)$) and 4 (at $(\pm 2,0)$), respectively.

(b) $(0,2)$

A-15: The minimum value is 0 on

$$\{ (x,y,z) \mid x \geq 0, y \geq 0, z \geq 0, 2x + y + z = 5, \text{ at least one of } x,y,z \text{ zero} \}$$

The maximum value is 4 at $(1,2,1)$.

A-16: (a) $x = 1, y = \frac{1}{2}, f(1, \frac{1}{2}) = 6$ (b) local minimum

(c) As x or y tends to infinity (with the other at least zero), $2x + 4y$ tends to $+\infty$. As (x,y) tends to any point on the first quadrant part of the x - and y -axes, $\frac{1}{xy}$ tends to $+\infty$. Hence as x or y tends to the boundary of the first quadrant (counting infinity as part of the boundary), $f(x,y)$ tends to $+\infty$. As a result $(1, \frac{1}{2})$ is a global (and not just local) minimum for f in the first quadrant. Hence $f(x,y) \geq f(1, \frac{1}{2}) = 6$ for all $x,y > 0$.

A-17: If $a < \frac{1}{2}$, then the closest point is the origin. If $a \geq \frac{1}{2}$, then the closest points are the level curve where $z = a - \frac{1}{2}$.

A-18:

(a) The total profit is given by

$$\Pi(x,y) = (15x^{0.8} - x) + (80y^{0.6} - 3y)$$

(b) The optimal production: $x = 248,832$ leading to 51840 reams of A4 and $y = 1,024$ leading to 640 reams of A3

(c) In this case, the optimal production is still 640 reams of A3

A-19:

(a) $\Pi_A(q_A) = -2q_A^2 + 120q_A - 2q_Aq_P$; maximum profit when $q_A = 30 - \frac{1}{2}q_P$

(b) $\Pi_P(q_P) = -2q_P^2 + 120q_P - 2q_Pq_A$; maximum profit when $q_P = 30 - \frac{1}{2}q_A$

(c) Their businesses are identical, so we predict they will sell the same amounts of lemonade.

(d) If Ayan and Pipe sell 20 pitchers they will maximize their respective profit functions.

(e) They would each make 800 dollars in profit.

(f) Their optimal joint profit will be 1,800 dollars. But, they need to share this profit among the two of them. So if they collaborate, they will each earn 900 dollars. This is more than their individual optimal profit in the scenario where they are competing found in part (e) (we found this to be \$800). So it is better for them to collaborate!

(g) Collaborating sellers lead to higher prices and fewer goods, so it's better for consumers with the sellers compete

Answers to Exercises 16.3 — Jump to [TABLE OF CONTENTS](#)

A-1: (a) f does not have a maximum. It does have a minimum.

(b) The minima are at $\pm(1, 1)$, where f takes the value 2.

A-2: One possible answer: $g(x, y) = y$, $f(x, y) = x^3 - x$.

A-3: There are none

A-4: The minimum value is $2^{\frac{1}{3}} + 2^{-\frac{2}{3}} = \frac{3}{2}\sqrt[3]{2} = \frac{3}{\sqrt[3]{4}}$ at $(\pm 2^{\frac{1}{6}}, 2^{-\frac{1}{3}})$.

A-5: The maximum and minimum values of f are $\frac{1}{2\sqrt{2}}$ and $-\frac{1}{2\sqrt{2}}$, respectively.

A-6: min = 1, max = $\sqrt{2}$.

A-7: absolute min $\frac{13-8\sqrt{2}}{3}$, absolute max $\frac{5}{3}$

A-8: $(\pm 1, 1/2)$

A-9: Largest $\frac{\sqrt{5}}{10-2\sqrt{5}}$, smallest $\frac{-\sqrt{5}}{10-2\sqrt{5}}$

A-10: (a) (i)

$$\begin{aligned}2xe^y &= \lambda(2x) \\ e^y(x^2 + y^2 + 2y) &= \lambda(2y) \\ x^2 + y^2 &= 100\end{aligned}$$

(a) (ii) The warmest point is $(0, 10)$ and the coolest point is $(0, -10)$.

(b) (i)

$$\begin{aligned}2xe^y &= 0 \\ e^y(x^2 + y^2 + 2y) &= 0\end{aligned}$$

(b) (ii) $(0, 0)$ and $(0, -2)$

(c) $(0, 0)$

A-11: Min 0; max $75 \cdot 2^{10/3}$

A-12: 4

A-13: $a = b = \sqrt{5}$

A-14: radius = $\sqrt{\frac{2}{3}}$ and height = $\frac{2}{\sqrt{3}}$.

A-15: $3 \times 6 \times 4$

A-16: See the solution.

A-17: Absolute minimum is 0, achieved at $(0, 1)$. There is no absolute maximum.

A-18: There are none.

A-19:

(a) There are none

(b) No

(c) The absolute maximum of $f(x, y)$ constrained to $x = y$ is $\frac{3^{3/4}}{4}$ and the absolute minimum is $-\frac{3^{3/4}}{4}$.

Part IV

SOLUTIONS TO PROBLEMS

Solutions to Exercises 1 — Jump to [TABLE OF CONTENTS](#)

Solutions to Exercises 2.1 — Jump to [TABLE OF CONTENTS](#)

S-1:

- (a) $\lim_{x \rightarrow -2} f(x) = 1$: as x gets very close to -2 , y gets very close to 1.
- (b) $\lim_{x \rightarrow 0} f(x) = 0$: as x gets very close to 0, y also gets very close to 0.
- (c) $\lim_{x \rightarrow 2} f(x) = 2$: as x gets very close to 2, y gets very close to 2. We ignore the value of the function where x is exactly 2.

S-2: The limit does not exist. As x approaches 0 *from the left*, y approaches -1 ; as x approaches 0 *from the right*, y approaches 1. This tells us $\lim_{x \rightarrow 0^-} f(x) = -1$ and $\lim_{x \rightarrow 0^+} f(x) = 1$, but neither of these are what the question asked. Since the limits from left and right do not agree, the limit does not exist. Put another way, there is no single number y approaches as x approaches 0, so the limit $\lim_{x \rightarrow 0} f(x)$ does not exist.

S-3:

- (a) $\lim_{x \rightarrow -1^-} f(x) = 2$: as x approaches -1 from the left, y approaches 2. It doesn't matter that the function isn't defined at $x = -1$, and it doesn't matter what happens to the right of $x = -1$.
- (b) $\lim_{x \rightarrow -1^+} f(x) = -2$: as x approaches -1 from the right, y approaches -2 . It doesn't matter that the function isn't defined at -1 , and it doesn't matter what happens to the left of -1 .
- (c) $\lim_{x \rightarrow -1} f(x) = \text{DNE}$: since the limits from the left and right don't agree, the limit does not exist.
- (d) $\lim_{x \rightarrow -2^+} f(x) = 0$: as x approaches -2 from the right, y approaches 0. It doesn't matter that the function isn't defined at 2, or to the left of 2.
- (e) $\lim_{x \rightarrow 2^-} f(x) = 0$: as x approaches 2 from the left, y approaches 0. It doesn't matter that the function isn't defined at 2, or to the right of 2.

S-4: Many answers are possible; here is one.

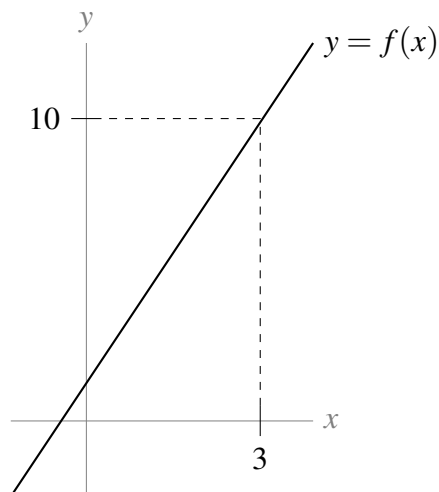

As x gets closer and closer to 3, y gets closer and closer to 10: this shows $\lim_{x \rightarrow 3} f(x) = 10$. Also, at 3 itself, the function takes the value 10; this shows $f(3) = 10$.

S-5: Many answers are possible; here is one.

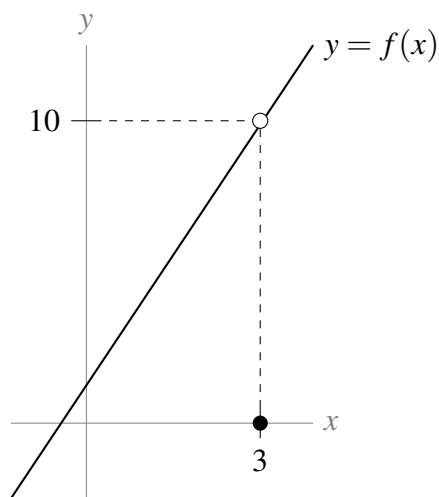

Note that, as x gets closer and closer to 3 *except at 3 itself*, y gets closer and closer to 10: this shows $\lim_{x \rightarrow 3} f(x) = 10$. Then, when $x = 3$, the function has value 0: this shows $f(3) = 0$.

S-6: In general, this is false. The limit as x goes to 3 does not take into account the value of the function at 3: $f(3)$ can be anything.

S-7: False. The limit as x goes to 3 does not take into account the value of the function at 3: $f(3)$ tells us nothing about $\lim_{x \rightarrow 3} f(x)$.

S-8: $\lim_{x \rightarrow -2^-} f(x) = 16$: in order for the limit $\lim_{x \rightarrow 2} f(x)$ to exist and be equal to 16, both one sided limits must exist and be equal to 16.

S-9: Not enough information to say. If $\lim_{x \rightarrow -2^+} f(x) = 16$, then $\lim_{x \rightarrow -2} f(x) = 16$. If $\lim_{x \rightarrow -2^+} f(x) \neq 16$, then $\lim_{x \rightarrow -2} f(x)$ does not exist.

S-10: $\lim_{t \rightarrow 0} \sin t = 0$: as t approaches 0, $\sin t$ approaches 0 as well.

S-11: $\lim_{x \rightarrow 0^+} \log x = -\infty$: as x approaches 0 from the right, $\log x$ is negative and increasingly large, growing without bound.

S-12: $\lim_{y \rightarrow 3} y^2 = 9$: as y gets closer and closer to 3, y^2 gets closer and closer to 3^2 .

S-13: $\lim_{x \rightarrow 0^-} \frac{1}{x} = -\infty$: as x gets closer and closer to 0 from the left, $\frac{1}{x}$ becomes a larger and larger negative number.

S-14: $\lim_{x \rightarrow 0} \frac{1}{x} = \text{DNE}$: as x gets closer and closer to 0 from the left, $\frac{1}{x}$ becomes a larger and larger negative number; but as x gets closer and closer to 0 from the right, $\frac{1}{x}$ becomes a larger and larger positive number. So the limit from the left is not the same as the limit from the right, and so $\lim_{x \rightarrow 0} \frac{1}{x} = \text{DNE}$. Contrast this with Question 15.

S-15: $\lim_{x \rightarrow 0} \frac{1}{x^2} = \infty$: as x gets closer and closer to 0 from the either side, $\frac{1}{x^2}$ becomes a larger and larger positive number, growing without bound. Contrast this with Question 14.

S-16: $\lim_{x \rightarrow 3} \frac{1}{10} = \frac{1}{10}$: no matter what x is, $\frac{1}{10}$ is always $\frac{1}{10}$. In particular, as x approaches 3, $\frac{1}{10}$ stays put at $\frac{1}{10}$.

S-17: When x is very close to 3, $f(x)$ looks like the function x^2 . So: $\lim_{x \rightarrow 3} f(x) = \lim_{x \rightarrow 3} x^2 = 9$

Solutions to Exercises 2.1.1 — Jump to [TABLE OF CONTENTS](#)

S-1: Zeroes cause a problem when they show up in the denominator, so we can only compute (a) and (d). (Both these limits are zero.) Be careful: there is no such rule as “zero divided by zero is one,” or “zero divided by zero is zero.”

S-2: The statement $\lim_{x \rightarrow 3} \frac{f(x)}{g(x)} = 10$ tells us that, as x gets very close to 3, $f(x)$ is 10 times as large as $g(x)$. We notice that if $f(x) = 10g(x)$, then $\frac{f(x)}{g(x)} = 10$, so $\lim_{x \rightarrow 3} \frac{f(x)}{g(x)} = 10$ wherever f and g

exist. So it's enough to find a function $g(x)$ that has limit 0 at 3. Such a function is (for example) $g(x) = x - 3$. So, we take $f(x) = 10(x - 3)$ and $g(x) = x - 3$. It is easy now to check that

$$\lim_{x \rightarrow 3} f(x) = \lim_{x \rightarrow 3} g(x) = 0 \text{ and } \lim_{x \rightarrow 3} \frac{f(x)}{g(x)} = \lim_{x \rightarrow 3} \frac{10(x-3)}{x-3} = \lim_{x \rightarrow 3} 10 = 10.$$

S-3:

- As we saw in Question 2, $x - 3$ is a function with limit 0 at $x = 3$. So one way of thinking about this question is to try choosing $f(x)$ so that $\frac{f(x)}{g(x)} = g(x) = x - 3$ too, which leads us to the solution $f(x) = (x - 3)^2$ and $g(x) = x - 3$. This is one of many, many possible answers.
- Another way of thinking about this problem is that $f(x)$ should go to 0 “more strongly” than $g(x)$ when x approaches 3. One way of a function going to 0 really strongly is to make that function identically zero. So we can set $f(x) = 0$ and $g(x) = x - 3$. Now $\frac{f(x)}{g(x)}$ is equal to 0 whenever $x \neq 3$, and is undefined at $x = 3$. Since the limit as x goes to three does not take into account the value of the function at 3, we have $\lim_{x \rightarrow 3} \frac{f(x)}{g(x)} = 0$.

There are many more possible answers.

S-4: One way to start this problem is to remember $\lim_{x \rightarrow 0} \frac{1}{x^2} = \infty$. (Using $\frac{1}{x^2}$ as opposed to $\frac{1}{x}$ is important, since $\lim_{x \rightarrow 0} \frac{1}{x}$ does not exist.) Then by “shifting” by three, we find $\lim_{x \rightarrow 3} \frac{1}{(x-3)^2} = \infty$. So it is enough to arrange that $\frac{f(x)}{g(x)} = \frac{1}{(x-3)^2}$. We can achieve this with $f(x) = x - 3$ and $g(x) = (x - 3)^3$, and maintain $\lim_{x \rightarrow 3} f(x) = \lim_{x \rightarrow 3} g(x) = 0$. Again, this is one of many possible solutions.

S-5: Any real number; positive infinity; negative infinity; does not exist.

This is an important thing to remember: often, people see limits that look like $\frac{0}{0}$ and think that the limit must be 1, or 0, or infinite. In fact, this limit could be anything—it depends on the relationship between f and g .

Questions 2 and 3 show us examples where the limit is 10 and 0; they can easily be modified to make the limit any real number.

Question 4 show us an example where the limit is ∞ ; it can easily be modified to make the limit $-\infty$ or DNE.

S-6: Since we're not trying to divide by 0, or multiply by infinity: $\lim_{t \rightarrow 10} \frac{2(t-10)^2}{t} = \frac{2 \cdot 0}{10} = 0$

S-7: Since we're not doing anything dodgy like putting 0 in the denominator,

$$\lim_{y \rightarrow 0} \frac{(y+1)(y+2)(y+3)}{\cos y} = \frac{(0+1)(0+2)(0+3)}{\cos 0} = \frac{6}{1} = 6.$$

S-8: Since the limits of the numerator and denominator exist, and since the limit of the denominator is nonzero: $\lim_{x \rightarrow 3} \left(\frac{4x-2}{x+2} \right)^4 = \left(\frac{4(3)-2}{3+2} \right)^4 = 16$

S-9:

$$\lim_{t \rightarrow -3} \left(\frac{1-t}{\cos(t)} \right) = \frac{\lim_{t \rightarrow -3} (1-t)}{\lim_{t \rightarrow -3} \cos(t)} = 4 / \cos(-3) = 4 / \cos(3)$$

S-10: If try naively then we get 0/0, so we expand and then simplify:

$$\frac{(2+h)^2 - 4}{2h} = \frac{h^2 + 4h + 4 - 4}{2h} = \frac{h}{2} + 2$$

Hence the limit is $\lim_{h \rightarrow 0} \left(\frac{h}{2} + 2 \right) = 2.$

S-11:

$$\lim_{t \rightarrow -2} \left(\frac{t-5}{t+4} \right) = \frac{\lim_{t \rightarrow -2} (t-5)}{\lim_{t \rightarrow -2} (t+4)} = -7/2.$$

S-12:

$$\lim_{t \rightarrow 1} \sqrt{5x^3 + 4} = \sqrt{\lim_{t \rightarrow 1} (5x^3 + 4)} = \sqrt{5 \lim_{t \rightarrow 1} (x^3) + 4} = \sqrt{9} = 3.$$

S-13:

$$\lim_{t \rightarrow -1} \left(\frac{t-2}{t+3} \right) = \frac{\lim_{t \rightarrow -1} (t-2)}{\lim_{t \rightarrow -1} (t+3)} = -3/2.$$

S-14: We simply plug in $x = 1$: $\lim_{x \rightarrow 1} \left[\frac{\log(1+x) - x}{x^2} \right] = \log(2) - 1.$

S-15: If we try naively then we get 0/0, so we simplify first:

$$\frac{x-2}{x^2-4} = \frac{x-2}{(x-2)(x+2)} = \frac{1}{x+2}$$

Hence the limit is $\lim_{x \rightarrow 2} \frac{1}{x+2} = 1/4.$

S-16: If we try to plug in $x = 4$, we find the denominator is zero. So to get a better idea of what's happening, we factor the numerator and denominator:

$$\begin{aligned}\lim_{x \rightarrow 4} \frac{x^2 - 4x}{x^2 - 16} &= \lim_{x \rightarrow 4} \frac{x(x-4)}{(x+4)(x-4)} \\ &= \lim_{x \rightarrow 4} \frac{x}{x+4} \\ &= \frac{4}{8} = \frac{1}{2}\end{aligned}$$

S-17: If we try to plug in $x = 2$, we find the denominator is zero. So to get a better idea of what's happening, we factor the numerator:

$$\begin{aligned}\lim_{x \rightarrow 2} \frac{x^2 + x - 6}{x - 2} &= \lim_{x \rightarrow 2} \frac{(x+3)(x-2)}{x-2} \\ &= \lim_{x \rightarrow 2} (x+3) = 5\end{aligned}$$

S-18: If we try naively then we get $0/0$, so we simplify first:

$$\frac{x^2 - 9}{x + 3} = \frac{(x-3)(x+3)}{(x+3)} = x - 3$$

Hence the limit is $\lim_{x \rightarrow -3} (x - 3) = -6$.

S-19: To calculate the limit of a polynomial, we simply evaluate the polynomial:

$$\lim_{t \rightarrow 2} \frac{1}{2}t^4 - 3t^3 + t = \frac{1}{2} \cdot 2^4 - 3 \cdot 2^3 + 2 = -14$$

S-20:

$$\begin{aligned}\frac{\sqrt{x^2+8}-3}{x+1} &= \frac{\sqrt{x^2+8}-3}{x+1} \cdot \frac{\sqrt{x^2+8}+3}{\sqrt{x^2+8}+3} \\ &= \frac{(x^2+8)-3^2}{(x+1)(\sqrt{x^2+8}+3)} \\ &= \frac{x^2-1}{(x+1)(\sqrt{x^2+8}+3)} \\ &= \frac{(x-1)(x+1)}{(x+1)(\sqrt{x^2+8}+3)} \\ &= \frac{(x-1)}{\sqrt{x^2+8}+3} \\ \lim_{x \rightarrow -1} \frac{\sqrt{x^2+8}-3}{x+1} &= \lim_{x \rightarrow -1} \frac{(x-1)}{\sqrt{x^2+8}+3} \\ &= \frac{-2}{\sqrt{9}+3} \\ &= -\frac{2}{6} = -\frac{1}{3}.\end{aligned}$$

S-21: If we try to do the limit naively we get $0/0$. Hence we must simplify.

$$\begin{aligned}\frac{\sqrt{x+2}-\sqrt{4-x}}{x-1} &= \frac{\sqrt{x+2}-\sqrt{4-x}}{x-1} \cdot \frac{\sqrt{x+2}+\sqrt{4-x}}{\sqrt{x+2}+\sqrt{4-x}} \\ &= \frac{(x+2)-(4-x)}{(x-1)(\sqrt{x+2}+\sqrt{4-x})} \\ &= \frac{2x-2}{(x-1)(\sqrt{x+2}+\sqrt{4-x})} \\ &= \frac{2}{\sqrt{x+2}+\sqrt{4-x}}\end{aligned}$$

So the limit is

$$\begin{aligned}\lim_{x \rightarrow 1} \frac{\sqrt{x+2}-\sqrt{4-x}}{x-1} &= \lim_{x \rightarrow 1} \frac{2}{\sqrt{x+2}+\sqrt{4-x}} \\ &= \frac{2}{\sqrt{3}+\sqrt{3}} \\ &= \frac{1}{\sqrt{3}}\end{aligned}$$

S-22: If we try to do the limit naively we get $0/0$. Hence we must simplify.

$$\begin{aligned}\frac{\sqrt{x-2}-\sqrt{4-x}}{x-3} &= \frac{\sqrt{x-2}-\sqrt{4-x}}{x-3} \cdot \frac{\sqrt{x-2}+\sqrt{4-x}}{\sqrt{x-2}+\sqrt{4-x}} \\ &= \frac{(x-2)-(4-x)}{(x-3)(\sqrt{x-2}+\sqrt{4-x})} \\ &= \frac{2x-6}{(x-3)(\sqrt{x-2}+\sqrt{4-x})} \\ &= \frac{2}{\sqrt{x-2}+\sqrt{4-x}} \\ \text{So, } \lim_{x \rightarrow 3} \frac{\sqrt{x-2}-\sqrt{4-x}}{x-3} &= \lim_{x \rightarrow 3} \frac{2}{\sqrt{x-2}+\sqrt{4-x}} \\ &= \frac{2}{1+1} \\ &= 1.\end{aligned}$$

S-23: First, let's think of some general principles.

- If you multiply any real number by 0, you get 0.
- We're multiplying $\cos\left(\frac{3}{x}\right)$ by a number that approaches 0 (but since we're taking a limit, we don't actually consider what happens when $x = 0$).

For any nonzero value of x (whether or not it's close to 0), $|\cos\left(\frac{3}{x}\right)| \leq 1$. So, its magnitude never gets very large. Since it's multiplied by something going to 0, the entire function will go to 0.

We can also see this by graphing the function. Note that $\cos\left(\frac{3}{x}\right)$ keeps cycling from 1, to 0, to -1, back to 0, etc, as x approaches 0.

- When $\cos\left(\frac{3}{x}\right) = 1$, $-x^2 \cos\frac{3}{x} = -x^2$;
- when $\cos\left(\frac{3}{x}\right) = 0$, $-x^2 \cos\frac{3}{x} = 0$; and
- when $\cos\left(\frac{3}{x}\right) = -1$, $-x^2 \cos\frac{3}{x} = x^2$.

So, we imagine the function $x^2 \cos\left(\frac{3}{x}\right)$ wiggling back and forth between x^2 and $-x^2$:

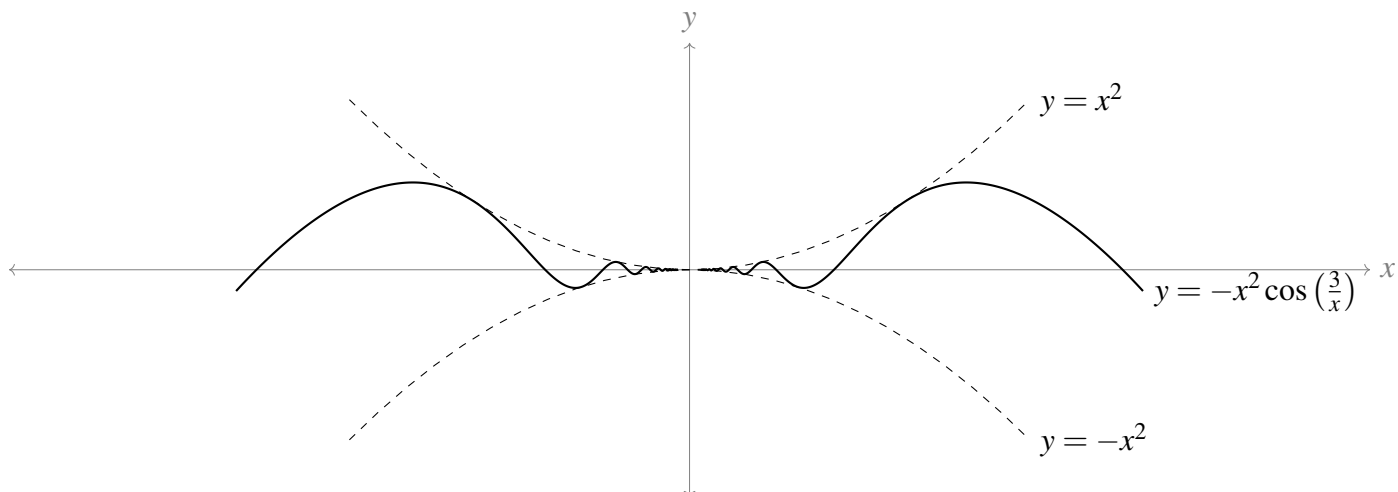

For x very close to 0, then, also $-x^2 \cos\left(\frac{3}{x}\right)$ is very close to 0. That is, $\lim_{x \rightarrow 0} -x^2 \cos\left(\frac{3}{x}\right) = 0$.

S-25: For any (nonzero) value of x , $0 \leq 1 \sin^2\left(\frac{1}{x}\right) \leq 1$. So when we multiply it by a number, that number either stays the same or gets closer to 0.

In particular, when we multiply x by $\sin^2\left(\frac{1}{x}\right)$, the result is either x itself, or something even closer to 0 than x was originally. Since x is approaching 0, $x \sin^2\left(\frac{1}{x}\right)$ is approaching 0 as well. That is,

$$\lim_{x \rightarrow 0} x \sin^2\left(\frac{1}{x}\right) = 0.$$

Another way to see this is by graphing. The factor $\sin^2\left(\frac{1}{x}\right) \leq 1$ cycles between 0 and 1, so the function $x \sin^2\left(\frac{1}{x}\right)$ cycles between 0 and x :

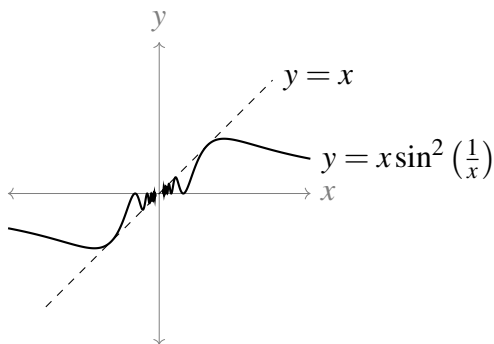

Again, we see $\lim_{x \rightarrow 0} x \sin^2\left(\frac{1}{x}\right) = 0$.

S-26: When we plug $w = 5$ in to the numerator and denominator, we find that each becomes zero. Since we can't divide by zero, we have to dig a little deeper. When a polynomial has a root, that also

means it has a factor: we can factor $(w - 5)$ out of the top. That lets us cancel:

$$\lim_{w \rightarrow 5} \frac{2w^2 - 50}{(w - 5)(w - 1)} = \lim_{w \rightarrow 5} \frac{2(w - 5)(w + 5)}{(w - 5)(w - 1)} = \lim_{w \rightarrow 5} \frac{2(w + 5)}{(w - 1)}.$$

Note that the function $\frac{2w^2 - 50}{(w - 5)(w - 1)}$ is NOT defined at $w = 5$, while the function $\frac{2(w + 5)}{(w - 1)}$ IS defined at $w = 5$; so strictly speaking, these two functions are not equal. However, for every value of w that is not 5, the functions are the same, so their *limits* are equal. Furthermore, the limit of the second function is quite easy to calculate, since we've eliminated the zero in the denominator:

$$\lim_{w \rightarrow 5} \frac{2(w + 5)}{(w - 1)} = \frac{2(5 + 5)}{5 - 1} = 5.$$

$$\text{So } \lim_{w \rightarrow 5} \frac{2w^2 - 50}{(w - 5)(w - 1)} = \lim_{w \rightarrow 5} \frac{2(w + 5)}{(w - 1)} = 5.$$

S-27: When we plug in $r = -5$ to the denominator, we find that it becomes 0, so we need to dig deeper. The numerator is not zero, so cancelling is out. Notice that the denominator is factorable: $r^2 + 10r + 25 = (r + 5)^2$. As r approaches -5 from either side, the denominator gets very close to zero, but stays positive. The numerator gets very close to -5 . So, as r gets closer to -5 , we have something close to -5 divided by a very small, positive number. Since the denominator is small, the fraction will have a large magnitude; since the numerator is negative and the denominator is positive, the fraction will be negative. So, $\lim_{r \rightarrow -5} \frac{r}{r^2 + 10r + 25} = -\infty$

S-28: First, we find $\lim_{x \rightarrow -1} \frac{x^3 + x^2 + x + 1}{3x + 3}$. When we plug in $x = -1$ to the top and the bottom, both become zero. In a polynomial, where there is a root, there is a factor, so this tells us we can factor out $(x + 1)$ from both the top and the bottom. It's pretty easy to see how to do this in the bottom. For the top, if you're having a hard time, one factoring method (of many) to try is long division of polynomials; another is to factor out $(x + 1)$ from the first two terms and the last two terms. (Detailed examples of long division are given in Appendix A.16 and Examples 1.10.2 and 1.10.3 of **CLP-2**.)

$$\begin{aligned} \lim_{x \rightarrow -1} \frac{x^3 + x^2 + x + 1}{3x + 3} &= \lim_{x \rightarrow -1} \frac{x^2(x + 1) + (x + 1)}{3x + 3} = \lim_{x \rightarrow -1} \frac{(x + 1)(x^2 + 1)}{3(x + 1)} \\ &= \lim_{x \rightarrow -1} \frac{x^2 + 1}{3} = \frac{(-1)^2 + 1}{3} = \frac{2}{3}. \end{aligned}$$

One thing to note here is that the function $\frac{x^3 + x^2 + x + 1}{3x + 3}$ is not defined at $x = -1$ (because we can't divide by zero). So we replaced it with the function $\frac{x^2 + 1}{3}$, which IS defined at $x = -1$. These functions only differ at $x = -1$; they are the same at every other point. That is why we can use the second function to find the limit of the first function.

Now we're ready to find the actual limit asked in the problem:

$$\lim_{x \rightarrow -1} \sqrt{\frac{x^3 + x^2 + x + 1}{3x + 3}} = \sqrt{\frac{2}{3}}.$$

S-29: When we plug $x = 0$ into the denominator, we get 0, which means we need to look harder. The numerator is not zero, so we won't be able to cancel our problems away. Let's factor to make things clearer.

$$\frac{x^2 + 2x + 1}{3x^5 - 5x^3} = \frac{(x + 1)^2}{x^3(3x^2 - 5)}$$

As x gets close to 0, the numerator is close to 1; the term $(3x^2 - 5)$ is negative; and the sign of x^3 depends on the direction we're approaching 0 from. Since we're dividing a numerator that is very close to 1 by something that's getting very close to 0, the magnitude of the fraction is getting bigger and bigger without bound. Since the sign of the fraction flips depending on whether we are using numbers slightly bigger than 0, or slightly smaller than 0, that means the one-sided limits are ∞ and $-\infty$, respectively. (In particular, $\lim_{x \rightarrow 0^-} \frac{x^2 + 2x + 1}{3x^5 - 5x^3} = \infty$ and $\lim_{x \rightarrow 0^+} \frac{x^2 + 2x + 1}{3x^5 - 5x^3} = -\infty$.) Since the one-sided limits don't agree, the limit does not exist.

S-30: As usual, we first try plugging in $t = 7$, but the denominator is 0, so we need to think harder.

The top and bottom are both squares, so let's go ahead and factor: $\frac{t^2x^2 + 2tx + 1}{t^2 - 14t + 49} = \frac{(tx + 1)^2}{(t - 7)^2}$.

Since x is positive, the numerator is nonzero. Also, the numerator is positive near $t = 7$. So, we have something positive and nonzero on the top, and we divide it by the bottom, which is positive and getting closer and closer to zero. The quotient is always positive near $t = 7$, and it is growing in magnitude without bound, so $\lim_{t \rightarrow 7} \frac{t^2x^2 + 2tx + 1}{t^2 - 14t + 49} = \infty$.

Remark: there is an important reason we specified that x must be a *positive* constant. Suppose x were $-\frac{1}{7}$ (which is negative and so was not allowed in the question posed). In this case, we would have

$$\begin{aligned} \lim_{t \rightarrow 7} \frac{t^2x^2 + 2tx + 1}{t^2 - 14t + 49} &= \lim_{t \rightarrow 7} \frac{(tx + 1)^2}{(t - 7)^2} \\ &= \lim_{t \rightarrow 7} \frac{(-t/7 + 1)^2}{(t - 7)^2} \\ &= \lim_{t \rightarrow 7} \frac{(-1/7)^2(t - 7)^2}{(t - 7)^2} \\ &= \lim_{t \rightarrow 7} (-1/7)^2 \\ &= \frac{1}{49} \\ &\neq \infty \end{aligned}$$

S-31: The function whose limit we are taking does not depend on d . Since x is a constant, $x^5 - 32x + 15$ is also a constant—it's just some number, that doesn't change, regardless of what d does. So $\lim_{d \rightarrow 0} x^5 - 32x + 15 = x^5 - 32x + 15$.

S-32: There's a lot going on inside that sine function... and we don't have to care about any of it. No matter what horrible thing we put inside a sine function, the sine function will spit out a number between -1 and 1 . So that means the entire function is somewhere between $(x-1)^2$ and $-(x-1)^2$. Since $(x-1)^2$ is approaching 0 , the entire function is approaching 0 .

That is, $\lim_{x \rightarrow 1} (x-1)^2 \sin \left[\left(\frac{x^2 - 3x + 2}{x^2 - 2x + 1} \right)^2 + 15 \right] = 0$.

S-33: Since $-1 \leq \sin x \leq 1$ for all values of x , when we multiply a number by this function, it causes the magnitude (absolute value) of that number to either be the same, or closer to 0 .

Since $\lim_{x \rightarrow 0} x^{1/101}$ is already 0 , the limit doesn't change when we multiply it by the sine part.

S-34:

$$\lim_{x \rightarrow 2} \frac{x^2 - 4}{x^2 - 2x} = \lim_{x \rightarrow 2} \frac{(x-2)(x+2)}{x(x-2)} = \lim_{x \rightarrow 2} \frac{x+2}{x} = 2$$

S-35: When we plug in $x = 5$ to the top and the bottom, both limits exist, and the bottom is nonzero. So $\lim_{x \rightarrow 5} \frac{(x-5)^2}{x+5} = \frac{0}{10} = 0$.

S-36: Since we can't plug in $t = \frac{1}{2}$, we'll simplify. One way to start is to add the fractions in the numerator. We'll need a common denominator, such as $3t^2(t^2 - 1)$.

$$\begin{aligned} \lim_{t \rightarrow \frac{1}{2}} \frac{\frac{1}{3t^2} + \frac{1}{t^2-1}}{2t-1} &= \lim_{t \rightarrow \frac{1}{2}} \frac{\frac{t^2-1}{3t^2(t^2-1)} + \frac{3t^2}{3t^2(t^2-1)}}{2t-1} \\ &= \lim_{t \rightarrow \frac{1}{2}} \frac{\frac{4t^2-1}{3t^2(t^2-1)}}{2t-1} \\ &= \lim_{t \rightarrow \frac{1}{2}} \frac{4t^2-1}{3t^2(t^2-1)(2t-1)} \\ &= \lim_{t \rightarrow \frac{1}{2}} \frac{(2t+1)(2t-1)}{3t^2(t^2-1)(2t-1)} \\ &= \lim_{t \rightarrow \frac{1}{2}} \frac{2t+1}{3t^2(t^2-1)} \end{aligned}$$

Since we cancelled out the term that was causing the numerator and denominator to be zero when $t = \frac{1}{2}$, now $t = \frac{1}{2}$ is in the domain of our function, so we simply plug it in:

$$\begin{aligned} &= \frac{1+1}{\frac{3}{4}\left(\frac{1}{4}-1\right)} \\ &= \frac{2}{\frac{3}{4}\left(-\frac{3}{4}\right)} \\ &= -\frac{32}{9} \end{aligned}$$

S-37: We recall that

$$|x| = \begin{cases} x & , x \geq 0 \\ -x & , x < 0 \end{cases}$$

So,

$$\begin{aligned} \frac{|x|}{x} &= \begin{cases} \frac{x}{x} & , x > 0 \\ \frac{-x}{x} & , x < 0 \end{cases} \\ &= \begin{cases} 1 & , x > 0 \\ -1 & , x < 0 \end{cases} \end{aligned}$$

Therefore,

$$3 + \frac{|x|}{x} = \begin{cases} 4 & , x > 0 \\ 2 & , x < 0 \end{cases}$$

Since our function gives a value of 4 when x is to the right of zero, and a value of 2 when x is to the left of zero, $\lim_{x \rightarrow 0} \left(3 + \frac{|x|}{x}\right)$ does not exist.

To further clarify the situation, the graph of $y = f(x)$ is sketched below:

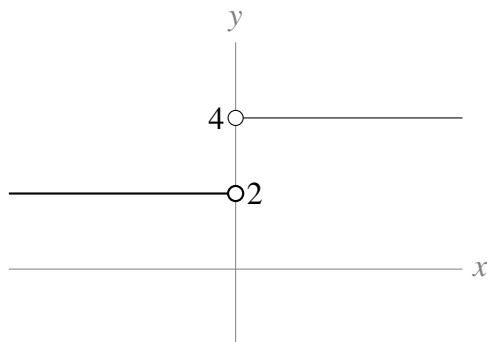

S-38: If we factor out 3 from the numerator, our function becomes $3 \frac{|d+4|}{d+4}$. We recall that

$$|X| = \begin{cases} X & , X \geq 0 \\ -X & , X < 0 \end{cases}$$

So, with $X = d + 4$,

$$3 \frac{|d+4|}{d+4} = \begin{cases} 3 \frac{d+4}{d+4} & , d+4 > 0 \\ 3 \frac{-(d+4)}{d+4} & , d+4 < 0 \end{cases}$$

$$= \begin{cases} 3 & , d > -4 \\ -3 & , d < -4 \end{cases}$$

Since our function gives a value of 3 when $d > -4$, and a value of -3 when $d < -4$,

$\lim_{d \rightarrow -4} \frac{|3d+12|}{d+4}$ does not exist.

To further clarify the situation, the graph of $y = f(x)$ is sketched below:

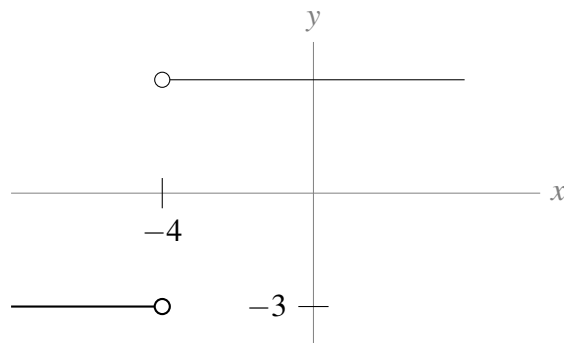

S-39: Note that $x = 0$ is in the domain of our function, and nothing “weird” is happening there: we aren’t dividing by zero, or taking the square root of a negative number, or joining two pieces of a piecewise-defined function. So, as x gets extremely close to zero, $\frac{5x-9}{|x|+2}$ is getting extremely close

to $\frac{0-9}{0+2} = \frac{-9}{2}$.

That is, $\lim_{x \rightarrow 0} \frac{5x-9}{|x|+2} = -\frac{9}{2}$.

S-40: Since we aren’t dividing by zero, and all these limits exist:

$$\lim_{x \rightarrow -1} \frac{xf(x)+3}{2f(x)+1} = \frac{(-1)(-1)+3}{2(-1)+1} = -4.$$

S-41: As $x \rightarrow -2$, the denominator goes to 0, and the numerator goes to $-2a + 7$. For the ratio to

have a limit, the numerator must also converge to 0, so we need $a = \frac{7}{2}$. Then,

$$\begin{aligned}\lim_{x \rightarrow -2} \frac{x^2 + ax + 3}{x^2 + x - 2} &= \lim_{x \rightarrow -2} \frac{x^2 + \frac{7}{2}x + 3}{(x+2)(x-1)} \\ &= \lim_{x \rightarrow -2} \frac{(x+2)(x + \frac{3}{2})}{(x+2)(x-1)} \\ &= \lim_{x \rightarrow -2} \frac{x + \frac{3}{2}}{x-1} \\ &= \frac{1}{6}\end{aligned}$$

so the limit exists when $a = \frac{7}{2}$.

S-42:

(a) $\lim_{x \rightarrow 0} f(x) = 0$: as x approaches 0, so does $2x$.

(b) $\lim_{x \rightarrow 0} g(x) = \text{DNE}$: the left and right limits do not agree, so the limit does not exist. In particular:
 $\lim_{x \rightarrow 0^-} g(x) = -\infty$ and $\lim_{x \rightarrow 0^+} g(x) = \infty$.

(c) $\lim_{x \rightarrow 0} f(x)g(x) = \lim_{x \rightarrow 0} 2x \cdot \frac{1}{x} = \lim_{x \rightarrow 0} 2 = 2$.

Remark: although the limit of $g(x)$ does not exist here, the limit of $f(x)g(x)$ does.

(d) $\lim_{x \rightarrow 0} \frac{f(x)}{g(x)} = \lim_{x \rightarrow 0} \frac{2x}{\frac{1}{x}} = \lim_{x \rightarrow 0} 2x^2 = 0$

(e) $\lim_{x \rightarrow 2} f(x) + g(x) = \lim_{x \rightarrow 2} 2x + \frac{1}{x} = 4 + \frac{1}{2} = \frac{9}{2}$

(f) $\lim_{x \rightarrow 0} \frac{f(x) + 1}{g(x + 1)} = \lim_{x \rightarrow 0} \frac{2x + 1}{\frac{1}{x+1}} = \frac{1}{1} = 1$

S-43: If we try to do the limit naively we get 0/0. Hence we must simplify.

$$\begin{aligned}\frac{\sqrt{x+7}-\sqrt{11-x}}{2x-4} &= \frac{\sqrt{x+7}-\sqrt{11-x}}{2x-4} \cdot \left(\frac{\sqrt{x+7}+\sqrt{11-x}}{\sqrt{x+7}+\sqrt{11-x}} \right) \\ &= \frac{(x+7)-(11-x)}{(2x-4)(\sqrt{x+7}+\sqrt{11-x})} \\ &= \frac{2x-4}{(2x-4)(\sqrt{x+7}+\sqrt{11-x})} \\ &= \frac{1}{\sqrt{x+7}+\sqrt{11-x}} \\ \text{So, } \lim_{x \rightarrow 2} \frac{\sqrt{x+7}-\sqrt{11-x}}{2x-4} &= \lim_{x \rightarrow 2} \frac{1}{\sqrt{x+7}+\sqrt{11-x}} \\ &= \frac{1}{\sqrt{9}+\sqrt{9}} \\ &= \frac{1}{6}\end{aligned}$$

S-44: Here we get 0/0 if we try the naive approach. Hence we must simplify.

$$\begin{aligned}\frac{3t-3}{2-\sqrt{5-t}} &= \frac{3t-3}{2-\sqrt{5-t}} \times \frac{2+\sqrt{5-t}}{2+\sqrt{5-t}} \\ &= (2+\sqrt{5-t}) \frac{3t-3}{2^2-(5-t)} \\ &= (2+\sqrt{5-t}) \frac{3t-3}{t-1} \\ &= (2+\sqrt{5-t}) \frac{3(t-1)}{t-1}\end{aligned}$$

So there is a cancelation. Hence the limit is

$$\begin{aligned}\lim_{t \rightarrow 1} \frac{3t-3}{2-\sqrt{5-t}} &= \lim_{t \rightarrow 1} (2+\sqrt{5-t}) \cdot 3 \\ &= 12\end{aligned}$$

S-45: We can begin by plotting the points that are easy to read off the diagram.

x	$f(x)$	$\frac{1}{f(x)}$
-3	-3	$-\frac{1}{3}$
-2	0	<i>UND</i>
-1	3	$\frac{1}{3}$
0	3	$\frac{1}{3}$
1	$\frac{3}{2}$	$\frac{2}{3}$
2	0	<i>UND</i>
3	1	1

Note that $\frac{1}{f(x)}$ is undefined when $f(x) = 0$. So $\frac{1}{f(x)}$ is undefined at $x = -2$ and $x = 2$. We shall look more closely at the behaviour of $\frac{1}{f(x)}$ for x near ± 2 shortly.

Plotting the above points, we get the following picture:

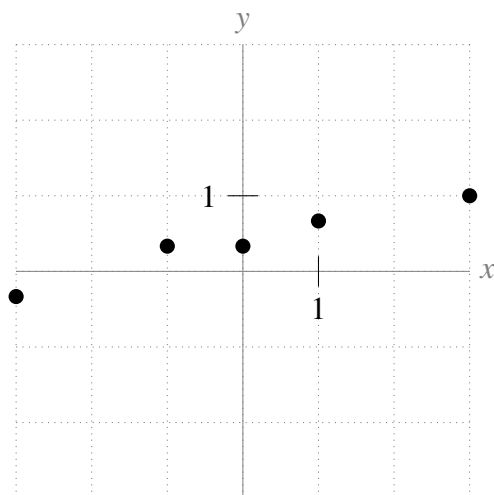

Since $f(x)$ is constant when x is between -1 and 0, then also $\frac{1}{f(x)}$ is constant between -1 and 0, so we update our picture:

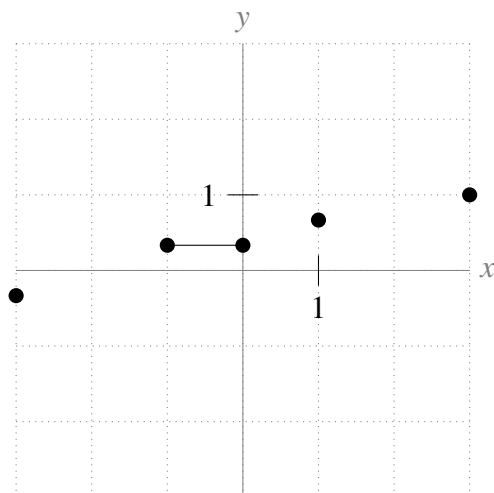

The big question that remains is the behaviour of $\frac{1}{f(x)}$ when x is near -2 and 2 . We can answer this question with limits. As x approaches -2 from the *left*, $f(x)$ gets closer to zero, and is negative. So $\frac{1}{f(x)}$ will be negative, and will increase in magnitude without bound; that is, $\lim_{x \rightarrow -2^-} \frac{1}{f(x)} = -\infty$. Similarly, as x approaches -2 from the *right*, $f(x)$ gets closer to zero, and is positive. So $\frac{1}{f(x)}$ will be positive, and will increase in magnitude without bound; that is, $\lim_{x \rightarrow -2^+} \frac{1}{f(x)} = \infty$. We add this behaviour to our graph:

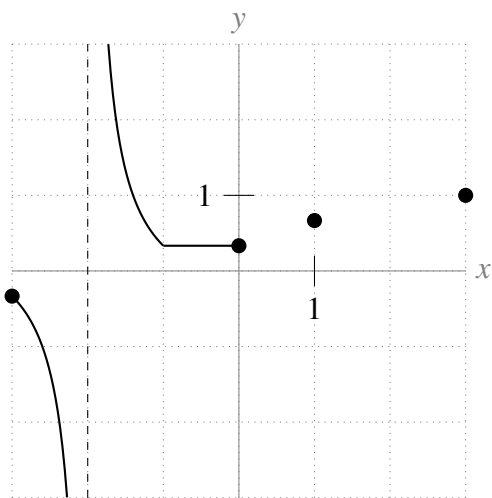

Now, we consider the behaviour at $x = 2$. Since $f(x)$ gets closer and closer to 0 AND is positive as x approaches 2, we conclude $\lim_{x \rightarrow 2} \frac{1}{f(x)} = \infty$. Adding to our picture:

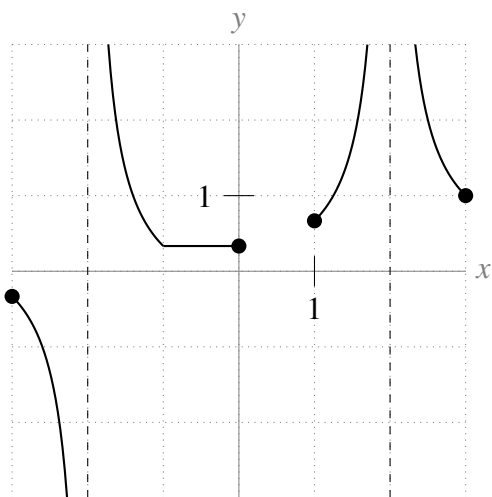

Now the only remaining blank space is between $x = 0$ and $x = 1$. Since $f(x)$ is a smooth curve that stays away from 0, we can draw some kind of smooth curve here, and call it good enough. (Later on we'll go into more details about drawing graphs. The purpose of this exercise was to utilize what we've learned about limits.)

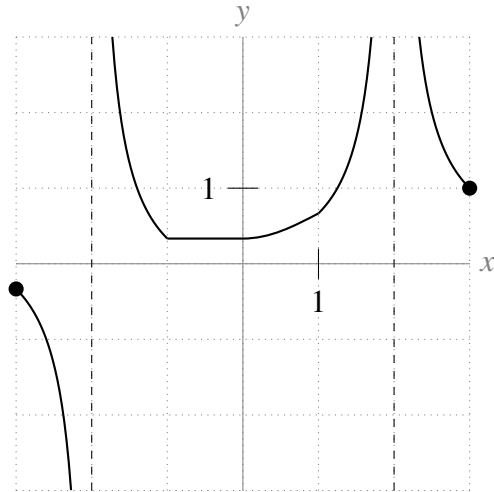

S-46: We can start by examining points.

x	$f(x)$	$g(x)$	$\frac{f(x)}{g(x)}$
-3	-3	-1.5	2
-2	0	0	UND
-1	3	1.5	2
-0	3	1.5	2
1	1.5	.75	2
2	0	0	UND
3	1	.5	2

We cannot divide by zero, so $\frac{f(x)}{g(x)}$ is not defined when $x = \pm 2$. But for every other value of x that we plotted, $f(x)$ is twice as large as $g(x)$, $\frac{f(x)}{g(x)} = 2$. With this in mind, we see that the graph of $f(x)$ is exactly the graph of $2g(x)$.

This gives us the graph below.

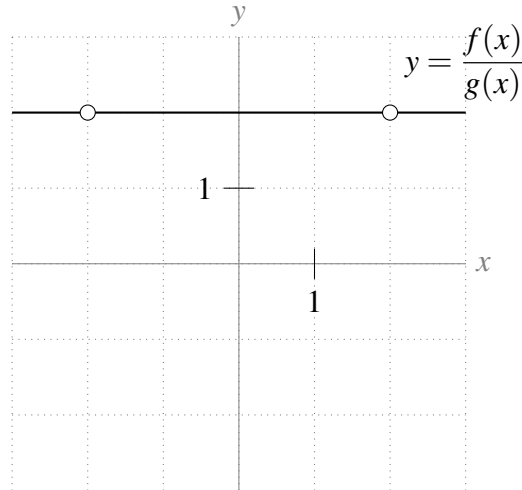

Remark: $f(2) = g(2) = 0$, so $\frac{f(2)}{g(2)}$ does not exist, but $\lim_{x \rightarrow 2} \frac{f(x)}{g(x)} = 2$. Although we are trying to “divide by zero” at $x = \pm 2$, it would be a mistake here to interpret this as a vertical asymptote.

S-47: (a) Neither limit exists. When x gets close to 0, these limits go to positive infinity from one side, and negative infinity from the other.

(b) $\lim_{x \rightarrow 0} [f(x) + g(x)] = \lim_{x \rightarrow 0} \left[\frac{1}{x} - \frac{1}{x} \right] = \lim_{x \rightarrow 0} 0 = 0.$

(c) No: this is an example of a time when the two individual functions have limits that don't exist, but the limit of their sum does exist. This “sum rule” is only true when both $\lim_{x \rightarrow a} f(x)$ and $\lim_{x \rightarrow a} g(x)$ exist.

S-48: (a) When we evaluate the limit from the left, we only consider values of x that are less than zero. For these values of x , our function is $x^2 - 3$. So, $\lim_{x \rightarrow 0^-} f(x) = \lim_{x \rightarrow 0^-} (x^2 - 3) = -3.$

(b) When we evaluate the limit from the right, we only consider values of x that are greater than zero. For these values of x , our function is $x^2 + 3$. So, $\lim_{x \rightarrow 0^+} f(x) = \lim_{x \rightarrow 0^+} (x^2 + 3) = 3.$

(c) Since the limits from the left and right do not agree, $\lim_{x \rightarrow 0} f(x) = \text{DNE}.$

To further clarify the situation, the graph of $y = f(x)$ is sketched below:

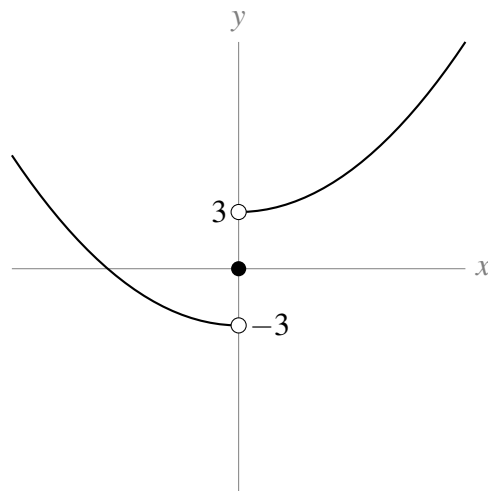

S-49: (a) When we evaluate $\lim_{x \rightarrow -4^-} f(x)$, we only consider values of x that are less than -4 . For these values, $f(x) = x^3 + 8x^2 + 16x$. So,

$$\lim_{x \rightarrow -4^-} f(x) = \lim_{x \rightarrow -4^-} (x^3 + 8x^2 + 16x) = (-4)^3 + 8(-4)^2 + 16(-4) = 0$$

Note that, because $x^3 + 8x^2 + 16x$ is a polynomial, we can evaluate the limit by directly substituting in $x = -4$.

(b) When we evaluate $\lim_{x \rightarrow -4^+} f(x)$, we only consider values of x that are greater than -4 . For these values,

$$f(x) = \frac{x^2 + 8x + 16}{x^2 + 30x - 4}$$

So,

$$\lim_{x \rightarrow -4^+} f(x) = \lim_{x \rightarrow -4^+} \frac{x^2 + 8x + 16}{x^2 + 30x - 4}$$

This is a rational function, and $x = -4$ is in its domain (we aren't doing anything suspect, like dividing by 0), so again we can directly substitute $x = -4$ to evaluate the limit:

$$= \frac{(-4)^2 + 8(-4) + 16}{(-4)^2 + 30(-4) - 4} = \frac{0}{-108} = 0$$

(c) Since $\lim_{x \rightarrow -4^-} f(x) = \lim_{x \rightarrow -4^+} f(x) = 0$, we conclude $\lim_{x \rightarrow -4} f(x) = 0$.

Solutions to Exercises 2.1.2 — Jump to [TABLE OF CONTENTS](#)

S-1: Any polynomial of degree one or higher will go to ∞ or $-\infty$ as x goes to ∞ . So, we need a polynomial of degree 0—that is, $f(x)$ is a constant. One possible answer is $f(x) = 1$.

S-2: This will be the case for any polynomial of *odd* degree. For instance, $f(x) = x$.

Many answers are possible: also $f(x) = x^{15} - 32x^2 + 9$ satisfies $\lim_{x \rightarrow \infty} f(x) = \infty$ and $\lim_{x \rightarrow -\infty} f(x) = -\infty$.

S-3: $\lim_{x \rightarrow \infty} 2^{-x} = \lim_{x \rightarrow \infty} \frac{1}{2^x} = 0$

S-4: As x gets larger and larger, 2^x grows without bound. (For integer values of x , you can imagine multiplying 2 by itself more and more times.) So, $\lim_{x \rightarrow \infty} 2^x = \infty$.

S-5: Write $X = -x$. As x becomes more and more negative, X becomes more and more positive. From Question 4, we know that 2^X grows without bound as X gets larger and larger. Since $2^x = 2^{-(-x)} = 2^{-X} = \frac{1}{2^X}$, as we let x become a huge negative number, we are in effect dividing by a huge positive number; hence $\lim_{x \rightarrow -\infty} 2^x = 0$.

A more formulaic way to describe the above is this: $\lim_{x \rightarrow -\infty} 2^x = \lim_{X \rightarrow \infty} 2^{-X} = \lim_{X \rightarrow \infty} \frac{1}{2^X} = 0$.

S-6: There is no single number that $\cos x$ approaches as x becomes more and more strongly negative: as x grows in the negative direction, the function oscillates between -1 and $+1$, never settling close to one particular number. So, this limit does not exist.

S-7: The highest-order term in this polynomial is $-3x^5$, so this dominates the function's behaviour as x goes to infinity. More formally:

$$\begin{aligned} \lim_{x \rightarrow \infty} (x - 3x^5 + 100x^2) &= \lim_{x \rightarrow \infty} -3x^5 \left(1 - \frac{1}{3x^4} - \frac{100}{3x^3} \right) \\ &= \lim_{x \rightarrow \infty} -3x^5 = -\infty \end{aligned}$$

because

$$\lim_{x \rightarrow \infty} \left(1 - \frac{1}{3x^4} - \frac{100}{3x^3} \right) = 1 - 0 - 0 = 1.$$

S-8: Our standard trick is to factor out the highest power of x in the denominator: x^4 . We just have to be a little careful with the square root. Since we are taking the limit as x goes to positive infinity, we have positive x -values, so $\sqrt{x^2} = x$ and $\sqrt{x^8} = x^4$.

$$\begin{aligned} \lim_{x \rightarrow \infty} \frac{\sqrt{3x^8 + 7x^4} + 10}{x^4 - 2x^2 + 1} &= \lim_{x \rightarrow \infty} \frac{\sqrt{x^8(3 + \frac{7}{x^4})} + 10}{x^4(1 - \frac{2}{x^2} + \frac{1}{x^4})} \\ &= \lim_{x \rightarrow \infty} \frac{\sqrt{x^8} \sqrt{3 + \frac{7}{x^4}} + 10}{x^4(1 - \frac{2}{x^2} + \frac{1}{x^4})} \\ &= \lim_{x \rightarrow \infty} \frac{x^4 \sqrt{3 + \frac{7}{x^4}} + 10}{x^4(1 - \frac{2}{x^2} + \frac{1}{x^4})} \\ &= \lim_{x \rightarrow \infty} \frac{x^4 \left(\sqrt{3 + \frac{7}{x^4} + \frac{10}{x^4}} \right)}{x^4(1 - \frac{2}{x^2} + \frac{1}{x^4})} \\ &= \lim_{x \rightarrow \infty} \frac{\sqrt{3 + \frac{7}{x^4} + \frac{10}{x^4}}}{1 - \frac{2}{x^2} + \frac{1}{x^4}} \\ &= \frac{\sqrt{3+0+0}}{1-0+0} = \sqrt{3} \end{aligned}$$

S-9: We have two terms, each getting extremely large. It's unclear at first what happens when we subtract them. To get this equation into another form, we multiply and divide by the conjugate, $\sqrt{x^2 + 5x} + \sqrt{x^2 - x}$.

$$\begin{aligned}\lim_{x \rightarrow \infty} [\sqrt{x^2 + 5x} - \sqrt{x^2 - x}] &= \lim_{x \rightarrow \infty} \left[\frac{(\sqrt{x^2 + 5x} - \sqrt{x^2 - x})(\sqrt{x^2 + 5x} + \sqrt{x^2 - x})}{\sqrt{x^2 + 5x} + \sqrt{x^2 - x}} \right] \\ &= \lim_{x \rightarrow \infty} \frac{(x^2 + 5x) - (x^2 - x)}{\sqrt{x^2 + 5x} + \sqrt{x^2 - x}} \\ &= \lim_{x \rightarrow \infty} \frac{6x}{\sqrt{x^2 + 5x} + \sqrt{x^2 - x}}\end{aligned}$$

Now we divide the numerator and denominator by x . In the case of the denominator, since $x > 0$, $x = \sqrt{x^2}$.

$$\begin{aligned}&= \lim_{x \rightarrow \infty} \frac{6(x)}{\sqrt{x^2} \sqrt{1 + \frac{5}{x}} + \sqrt{x^2} \sqrt{1 - \frac{1}{x}}} \\ &= \lim_{x \rightarrow \infty} \frac{6(x)}{(x) \sqrt{1 + \frac{5}{x}} + (x) \sqrt{1 - \frac{1}{x}}} \\ &= \lim_{x \rightarrow \infty} \frac{6}{\sqrt{1 + \frac{5}{x}} + \sqrt{1 - \frac{1}{x}}} \\ &= \frac{6}{\sqrt{1 + 0} + \sqrt{1 - 0}} = 3\end{aligned}$$

S-10: Note that for large negative x , the first term in the denominator $\sqrt{4x^2 + x} \approx \sqrt{4x^2} = |2x| = -2x$ *not* $+2x$. A good way to avoid incorrectly computing $\sqrt{x^2}$ when x is negative is to define $y = -x$ and express everything in terms of y . That's what we'll do.

$$\begin{aligned}\lim_{x \rightarrow -\infty} \frac{3x}{\sqrt{4x^2 + x} - 2x} &= \lim_{y \rightarrow +\infty} \frac{-3y}{\sqrt{4y^2 - y} + 2y} \\ &= \lim_{y \rightarrow +\infty} \frac{-3y}{y \sqrt{4 - \frac{1}{y}} + 2y} \\ &= \lim_{y \rightarrow +\infty} \frac{-3}{\sqrt{4 - \frac{1}{y}} + 2} \\ &= \frac{-3}{\sqrt{4 - 0} + 2} \quad \text{since } 1/y \rightarrow 0 \text{ as } y \rightarrow +\infty \\ &= -\frac{3}{4}\end{aligned}$$

S-11: The highest power of x in the denominator is x^2 , so we divide the numerator and denominator

by x^2 :

$$\begin{aligned}\lim_{x \rightarrow -\infty} \frac{1-x-x^2}{2x^2-7} &= \lim_{x \rightarrow -\infty} \frac{1/x^2 - 1/x - 1}{2 - 7/x^2} \\ &= \frac{0-0-1}{2-0} = -\frac{1}{2}\end{aligned}$$

S-12:

$$\begin{aligned}\lim_{x \rightarrow \infty} (\sqrt{x^2+x} - x) &= \lim_{x \rightarrow \infty} \frac{(\sqrt{x^2+x} - x)(\sqrt{x^2+x} + x)}{\sqrt{x^2+x} + x} = \lim_{x \rightarrow \infty} \frac{(x^2+x) - x^2}{\sqrt{x^2+x} + x} \\ &= \lim_{x \rightarrow \infty} \frac{x}{\sqrt{x^2+x} + x} = \lim_{x \rightarrow \infty} \frac{1}{\sqrt{1 + \frac{1}{x}} + 1} = \frac{1}{2}\end{aligned}$$

S-13: We have, after dividing both numerator and denominator by x^2 (which is the highest power of the denominator) that

$$\frac{5x^2 - 3x + 1}{3x^2 + x + 7} = \frac{5 - \frac{3}{x} + \frac{1}{x^2}}{3 + \frac{1}{x} + \frac{7}{x^2}}.$$

Since $1/x \rightarrow 0$ and also $1/x^2 \rightarrow 0$ as $x \rightarrow +\infty$, we conclude that

$$\lim_{x \rightarrow +\infty} \frac{5x^2 - 3x + 1}{3x^2 + x + 7} = \frac{5}{3}.$$

S-14: We have, after dividing both numerator and denominator by x (which is the highest power of the denominator) that

$$\frac{\sqrt{4x+2}}{3x+4} = \frac{\sqrt{\frac{4}{x} + \frac{2}{x^2}}}{3 + \frac{4}{x}}.$$

Since $1/x \rightarrow 0$ and also $1/x^2 \rightarrow 0$ as $x \rightarrow +\infty$, we conclude that

$$\lim_{x \rightarrow +\infty} \frac{\sqrt{4x+2}}{3x+4} = \frac{0}{3} = 0.$$

S-15: The dominant terms in the numerator and denominator have order x^3 . Taking out that common factor we get

$$\frac{4x^3 + x}{7x^3 + x^2 - 2} = \frac{4 + \frac{1}{x^2}}{7 + \frac{1}{x} - \frac{2}{x^3}}.$$

Since $1/x^a \rightarrow 0$ as $x \rightarrow +\infty$ (for $a > 0$), we conclude that

$$\lim_{x \rightarrow +\infty} \frac{4x^3 + x}{7x^3 + x^2 - 2} = \frac{4}{7}.$$

S-16:

• Solution 1

We want to factor out x , the highest power in the denominator. Since our limit only sees negative values of x , we must remember that $\sqrt[4]{x^4} = |x| = -x$, although $\sqrt[3]{x^3} = x$.

$$\begin{aligned} \lim_{x \rightarrow -\infty} \frac{\sqrt[3]{x^2 + x} - \sqrt[4]{x^4 + 5}}{x + 1} &= \lim_{x \rightarrow -\infty} \frac{\sqrt[3]{x^3(\frac{1}{x} + \frac{1}{x^2})} - \sqrt[4]{x^4(1 + \frac{5}{x^4})}}{x(1 + \frac{1}{x})} \\ &= \lim_{x \rightarrow -\infty} \frac{\sqrt[3]{x^3} \sqrt[3]{\frac{1}{x} + \frac{1}{x^2}} - \sqrt[4]{x^4} \sqrt[4]{1 + \frac{5}{x^4}}}{x(1 + \frac{1}{x})} \\ &= \lim_{x \rightarrow -\infty} \frac{x \sqrt[3]{\frac{1}{x} + \frac{1}{x^2}} - (-x) \sqrt[4]{1 + \frac{5}{x^4}}}{x(1 + \frac{1}{x})} \\ &= \lim_{x \rightarrow -\infty} \frac{\sqrt[3]{\frac{1}{x} + \frac{1}{x^2}} + \sqrt[4]{1 + \frac{5}{x^4}}}{1 + \frac{1}{x}} \\ &= \frac{\sqrt[3]{0 + 0} + \sqrt[4]{1 + 0}}{1 + 0} = 1 \end{aligned}$$

• Solution 2

Alternately, we can use the transformation $\lim_{x \rightarrow -\infty} f(x) = \lim_{x \rightarrow \infty} f(-x)$. Then we only look at positive values of x , so roots behave nicely: $\sqrt[4]{x^4} = |x| = x$.

$$\begin{aligned} \lim_{x \rightarrow -\infty} \frac{\sqrt[3]{x^2 + x} - \sqrt[4]{x^4 + 5}}{x + 1} &= \lim_{x \rightarrow \infty} \frac{\sqrt[3]{(-x)^2 - x} - \sqrt[4]{(-x)^4 + 5}}{-x + 1} \\ &= \lim_{x \rightarrow \infty} \frac{\sqrt[3]{x^2 - x} - \sqrt[4]{x^4 + 5}}{-x + 1} \\ &= \lim_{x \rightarrow \infty} \frac{\sqrt[3]{x^3} \sqrt[3]{\frac{1}{x} - \frac{1}{x^2}} - \sqrt[4]{x^4} \sqrt[4]{1 + \frac{5}{x^4}}}{x(-1 + \frac{1}{x})} \\ &= \lim_{x \rightarrow \infty} \frac{x \sqrt[3]{\frac{1}{x} - \frac{1}{x^2}} - x \sqrt[4]{1 + \frac{5}{x^4}}}{x(-1 + \frac{1}{x})} \\ &= \lim_{x \rightarrow \infty} \frac{\sqrt[3]{\frac{1}{x} - \frac{1}{x^2}} - \sqrt[4]{1 + \frac{5}{x^4}}}{-1 + \frac{1}{x}} \\ &= \frac{\sqrt[3]{0 - 0} - \sqrt[4]{1 + 0}}{-1 + 0} = \frac{-1}{-1} = 1 \end{aligned}$$

S-17: We have, after dividing both numerator and denominator by x^3 (which is the highest power of the denominator) that:

$$\lim_{x \rightarrow \infty} \frac{5x^2 + 10}{3x^3 + 2x^2 + x} = \lim_{x \rightarrow \infty} \frac{\frac{5}{x} + \frac{10}{x^3}}{3 + \frac{2}{x} + \frac{1}{x^2}} = \frac{0}{3} = 0.$$

S-18: Since we only consider negative values of x , $\sqrt{x^2} = |x| = -x$.

$$\begin{aligned}\lim_{x \rightarrow -\infty} \frac{x+1}{\sqrt{x^2}} &= \lim_{x \rightarrow -\infty} \frac{x+1}{-x} \\ &= \lim_{x \rightarrow -\infty} \frac{x}{-x} + \frac{1}{-x} \\ &= \lim_{x \rightarrow -\infty} -1 - \frac{1}{x} \\ &= -1\end{aligned}$$

S-19: Since we only consider positive values of x , $\sqrt{x^2} = |x| = x$.

$$\begin{aligned}\lim_{x \rightarrow \infty} \frac{x+1}{\sqrt{x^2}} &= \lim_{x \rightarrow \infty} \frac{x+1}{x} \\ &= \lim_{x \rightarrow \infty} 1 + \frac{1}{x} = 1 + 0 = 1\end{aligned}$$

S-20: When $x < 0$, $|x| = -x$ and so $\lim_{x \rightarrow \infty} \sin\left(\frac{\pi}{2} \cdot \frac{|x|}{x}\right) + \frac{1}{x} = \sin(-\pi/2) = -1$.

S-21: We divide both the numerator and the denominator by the highest power of x in the denominator, which is x . Since $x < 0$, we have $\sqrt{x^2} = |x| = -x$, so that

$$\frac{\sqrt{x^2+5}}{x} = -\sqrt{\frac{x^2+5}{x^2}} = -\sqrt{1+\frac{5}{x^2}}.$$

Since $1/x \rightarrow 0$ and also $1/x^2 \rightarrow 0$ as $x \rightarrow -\infty$, we conclude that

$$\lim_{x \rightarrow -\infty} \frac{3x+5}{\sqrt{x^2+5}-x} = \lim_{x \rightarrow -\infty} \frac{3+\frac{5}{x}}{-\sqrt{1+\frac{5}{x^2}}-1} = \frac{3}{-1-1} = -\frac{3}{2}.$$

S-22: We divide both the numerator and the denominator by the highest power of x in the denominator, which is x . Since $x < 0$, we have $\sqrt{x^2} = |x| = -x$, so that

$$\frac{\sqrt{4x^2+15}}{x} = \frac{\sqrt{4x^2+15}}{-\sqrt{x^2}} = -\sqrt{\frac{4x^2+15}{x^2}} = -\sqrt{4+\frac{15}{x^2}}.$$

Since $1/x \rightarrow 0$ and also $1/x^2 \rightarrow 0$ as $x \rightarrow -\infty$, we conclude that

$$\lim_{x \rightarrow -\infty} \frac{5x+7}{\sqrt{4x^2+15}-x} = \lim_{x \rightarrow -\infty} \frac{5+\frac{7}{x}}{-\sqrt{4+\frac{15}{x^2}}-1} = \frac{5}{-2-1} = -\frac{5}{3}.$$

S-23:

$$\begin{aligned}\lim_{x \rightarrow -\infty} \frac{3x^7 + x^5 - 15}{4x^2 + 32x} &= \lim_{x \rightarrow -\infty} \frac{x^2(3x^5 + x^3 - \frac{15}{x^2})}{x^2(4 + \frac{32}{x})} \\ &= \lim_{x \rightarrow -\infty} \frac{3x^5 + x^3 - \frac{15}{x^2}}{4 + \frac{32}{x}} \\ &= \lim_{x \rightarrow +\infty} \frac{3(-x)^5 + (-x)^3 - \frac{15}{(-x)^2}}{4 + \frac{32}{-x}} \\ &= \lim_{x \rightarrow +\infty} \frac{-3x^5 - x^3 - \frac{15}{x^2}}{4 - \frac{32}{x}} \\ &= -\infty\end{aligned}$$

S-24: We multiply and divide the expression by its conjugate, $(\sqrt{n^2 + 5n} + n)$.

$$\begin{aligned}\lim_{n \rightarrow \infty} (\sqrt{n^2 + 5n} - n) &= \lim_{n \rightarrow \infty} (\sqrt{n^2 + 5n} - n) \left(\frac{\sqrt{n^2 + 5n} + n}{\sqrt{n^2 + 5n} + n} \right) \\ &= \lim_{n \rightarrow \infty} \frac{(n^2 + 5n) - n^2}{\sqrt{n^2 + 5n} + n} \\ &= \lim_{n \rightarrow \infty} \frac{5n}{\sqrt{n^2 + 5n} + n} \\ &= \lim_{n \rightarrow \infty} \frac{5 \cdot n}{\sqrt{n^2} \sqrt{1 + \frac{5}{n}} + n}\end{aligned}$$

Since $n > 0$, we can simplify $\sqrt{n^2} = n$.

$$\begin{aligned}&= \lim_{n \rightarrow \infty} \frac{5 \cdot n}{n \sqrt{1 + \frac{5}{n}} + n} \\ &= \lim_{n \rightarrow \infty} \frac{5}{\sqrt{1 + \frac{5}{n}} + 1} \\ &= \frac{5}{\sqrt{1 + 0} + 1} = \frac{5}{2}\end{aligned}$$

S-25:

• **Solution 1:**

When a approaches 0 from the right, the numerator approaches negative infinity, and the

denominator approaches -1 . So, $\lim_{a \rightarrow 0^+} \frac{a^2 - \frac{1}{a}}{a - 1} = \infty$.

More precisely, using Theorem 2.1.35:

$$\lim_{a \rightarrow 0^+} \frac{1}{a} = +\infty$$

$$\text{Also, } \lim_{a \rightarrow 0^+} a^2 = 0$$

$$\text{So, using Theorem 2.1.35, } \lim_{a \rightarrow 0^+} a^2 - \frac{1}{a} = -\infty$$

$$\text{Furthermore, } \lim_{a \rightarrow 0^+} a - 1 = -1$$

$$\text{So, using our theorem, } \lim_{a \rightarrow 0^+} \frac{a^2 - \frac{1}{a}}{a - 1} = \infty$$

• **Solution 2:**

Since $a = 0$ is not in the domain of our function, a reasonable impulse is to simplify.

$$\frac{a^2 - \frac{1}{a}}{a - 1} \left(\frac{a}{a} \right) = \frac{a^3 - 1}{a(a - 1)} = \frac{(a - 1)(a^2 + a + 1)}{a(a - 1)}$$

So,

$$\begin{aligned} \lim_{a \rightarrow 0^+} \frac{a^2 - \frac{1}{a}}{a - 1} &= \lim_{a \rightarrow 0^+} \frac{(a - 1)(a^2 + a + 1)}{a(a - 1)} \\ &= \lim_{a \rightarrow 0^+} \frac{a^2 + a + 1}{a} \\ &= \lim_{a \rightarrow 0^+} a + 1 + \frac{1}{a} = \infty \end{aligned}$$

S-26:

Since $x = 3$ is not in the domain of the function, we simplify, hoping we can cancel a problematic term.

$$\begin{aligned} \lim_{x \rightarrow 3} \frac{2x + 8}{\frac{1}{x-3} + \frac{1}{x^2-9}} &= \lim_{x \rightarrow 3} \frac{2x + 8}{\frac{x+3}{x^2-9} + \frac{1}{x^2-9}} \\ &= \lim_{x \rightarrow 3} \frac{2x + 8}{\frac{x+4}{x^2-9}} \\ &= \lim_{x \rightarrow 3} \frac{(2x + 8)(x^2 - 9)}{x + 4} = 0 \end{aligned}$$

S-27: First, we need a rational function whose limit at infinity is a real number. This means that the degree of the bottom is greater than or equal to the degree of the top. There are two cases: the denominator has higher degree than the numerator, or the denominator has the same degree as the numerator.

If the denominator has higher degree than the numerator, then $\lim_{x \rightarrow \infty} f(x) = \lim_{x \rightarrow -\infty} f(x) = 0$, so the limits are equal—not what we're looking for.

If the denominator has the same degree as the numerator, then the limit as x goes to $\pm\infty$ is the ratio of the leading terms: again, the limits are equal. So no rational function exists as described.

S-28: The amount of the substance that will linger long-term is some positive number—the substance will stick around. One example of a substance that does this is the ink in a tattoo. (If the injection was of medicine, probably it will be metabolized, and $\lim_{t \rightarrow \infty} c(t) = 0$.)

Remark: it actually doesn't make much sense to let t go to infinity: after a few million hours, you won't even have a body, so what is $c(t)$ measuring? Often when we use formulas in the real world, there is an understanding that they are only good for some fixed range. We often use the limit as t goes to infinity as a stand-in for the function's long-term behaviour.

Solutions to Exercises 2.2 — Jump to [TABLE OF CONTENTS](#)

Solutions to Exercises 2.3 — Jump to [TABLE OF CONTENTS](#)

S-1: Many answers are possible; the tangent function behaves like this.

S-2: True. Since $f(t)$ is continuous at $t = 5$, that means $\lim_{t \rightarrow 5} f(t) = f(5)$. For that to be true, $f(5)$ must exist — that is, 5 is in the domain of $f(x)$.

S-3: True. Using the definition of continuity, $\lim_{t \rightarrow 5} f(t) = f(5) = 17$.

S-4: In general, false. If $f(t)$ is continuous at $t = 5$, then $f(5) = 17$; if $f(t)$ is discontinuous at $t = 5$, then $f(5)$ either does not exist, or is a number other than 17.

An example of a function with $\lim_{t \rightarrow 5} f(t) = 17 \neq f(5)$ is $f(t) = \begin{cases} 17 & , t \neq 5 \\ 0 & , t = 5 \end{cases}$, shown below.

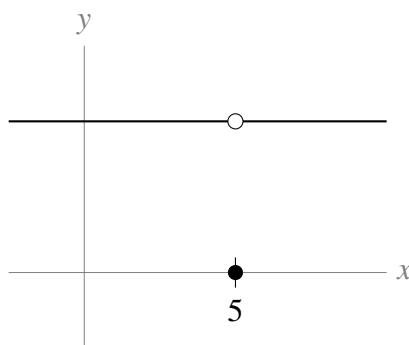

S-5: Since $f(x)$ and $g(x)$ are continuous at zero, and since $g^2(x) + 1$ must be nonzero, then $h(x)$ is continuous at 0 as well. According to the definition of continuity, then $\lim_{x \rightarrow 0} h(x)$ exists and is equal to $h(0) = \frac{0f(0)}{g^2(0)+1} = 0$.

Since the limit $\lim_{x \rightarrow 0} h(x)$ exists and is equal to zero, also the one-sided limit $\lim_{x \rightarrow 0^+} h(x)$ exists and is equal to zero.

S-6: Using the definition of continuity, we need $k = \lim_{x \rightarrow 0} f(x)$. Since the limit is blind to what actually happens to $f(x)$ at $x = 0$, this is equivalent to $k = \lim_{x \rightarrow 0} x \sin\left(\frac{1}{x}\right)$. So if we find the limit, we solve the problem.

For any nonzero value of x , $-1 \leq \sin\left(\frac{1}{x}\right) \leq 1$. So if we multiply x by $\sin\left(\frac{1}{x}\right)$, the magnitude (absolute value) of x either stays the same or gets closer to 0. Since x is already approaching 0, $\lim_{x \rightarrow 0} x \sin\left(\frac{1}{x}\right) = 0$.

So, when $k = 0$, the function is continuous at $x = 0$.

S-7: $f(x)$ is a rational function and so is continuous except when its denominator is zero. That is, except when $x = 1$ and $x = -1$.

S-8: The function is continuous when $x^2 - 1 > 0$, i.e. $(x - 1)(x + 1) > 0$, which yields the intervals $(-\infty, -1) \cup (1, +\infty)$.

S-9: The function $1/\sqrt{x}$ is continuous on $(0, +\infty)$ and the function $\cos(x) + 1$ is continuous everywhere.

So $1/\sqrt{\cos(x) + 1}$ is continuous except when $\cos x = -1$. This happens when x is an odd multiple of π . Hence the function is continuous except at $x = \pm\pi, \pm 3\pi, \pm 5\pi, \dots$

S-10: The function is continuous when $\sin(x) \neq 0$. That is, when x is not an integer multiple of π .

S-11: The function is continuous for $x \neq c$ since each of those two branches are polynomials. So, the only question is whether the function is continuous at $x = c$; for this we need

$$\lim_{x \rightarrow c^-} f(x) = f(c) = \lim_{x \rightarrow c^+} f(x).$$

We compute

$$\lim_{x \rightarrow c^-} f(x) = \lim_{x \rightarrow c^-} 8 - cx = 8 - c^2;$$

$$f(c) = 8 - c \cdot c = 8 - c^2 \text{ and}$$

$$\lim_{x \rightarrow c^+} f(x) = \lim_{x \rightarrow c^+} x^2 = c^2.$$

So, we need $8 - c^2 = c^2$, which yields $c^2 = 4$, i.e. $c = -2$ or $c = 2$.

S-12: The function is continuous for $x \neq 0$ since $x^2 + c$ and $\cos cx$ are continuous everywhere. It remains to check continuity at $x = 0$. To do this we must check that the following three are equal.

$$\begin{aligned}\lim_{x \rightarrow 0^+} f(x) &= \lim_{x \rightarrow 0^+} x^2 + c = c \\ f(0) &= c \\ \lim_{x \rightarrow 0^-} f(x) &= \lim_{x \rightarrow 0^-} \cos cx = \cos 0 = 1\end{aligned}$$

Hence when $c = 1$ we have the limits agree.

S-13: The function is continuous for $x \neq c$ since each of those two branches are defined by polynomials. Thus, the only question is whether the function is continuous at $x = c$. Furthermore,

$$\lim_{x \rightarrow c^-} f(x) = c^2 - 4$$

and

$$\lim_{x \rightarrow c^+} f(x) = f(c) = 3c.$$

For continuity we need both limits and the value to agree, so f is continuous if and only if $c^2 - 4 = 3c$, that is if and only if

$$c^2 - 3c - 4 = 0.$$

Factoring this as $(c - 4)(c + 1) = 0$ yields $c = -1$ or $c = +4$.

S-14: The function is continuous for $x \neq c$ since each of those two branches are polynomials. So, the only question is whether the function is continuous at $x = c$; for this we need

$$\lim_{x \rightarrow 2c^-} f(x) = f(2c) = \lim_{x \rightarrow 2c^+} f(x).$$

We compute

$$\lim_{x \rightarrow 2c^-} f(x) = \lim_{x \rightarrow 2c^-} 6 - cx = 6 - 2c^2;$$

$$f(2c) = 6 - c \cdot 2c = 6 - 2c^2 \text{ and}$$

$$\lim_{x \rightarrow 2c^+} f(x) = \lim_{x \rightarrow 2c^+} x^2 = 4c^2.$$

So, we need $6 - 2c^2 = 4c^2$, which yields $c^2 = 1$, i.e. $c = -1$ or $c = 1$.

No exercises for Section 3.1. — Jump to [TABLE OF CONTENTS](#)

Solutions to Exercises 3.2 — Jump to [TABLE OF CONTENTS](#)

S-1: If Q is to the left of the y axis, the line through Q and P is increasing, so the secant line has positive slope. If Q is to the right of the y axis, the line through Q and P is decreasing, so the secant line has negative slope.

S-2: (a) By drawing a few pictures, it's easy to see that sliding Q closer to P , the slope of the secant line increases.

(b) Since the slope of the secant line increases the closer Q gets to P , that means the tangent line (which is the limit as Q approaches P) has a larger slope than the secant line between Q and P (using the location where Q is right now).

Alternately, by simply sketching the tangent line at P , we can see that has a steeper slope than the secant line between P and Q .

S-3: The slope of the secant line will be $\frac{f(2) - f(-2)}{2 - (-2)} = \frac{f(2) - f(-2)}{4}$, in every part. So, if two lines have the same slope, that means their differences $f(2) - f(-2)$ will be the same.

The graphs in (a),(c), and (e) all have $f(2) - f(-2) = 1$, so they all have the same secant line slope. The graphs in (b) and (f) both have $f(2) - f(-2) = -1$, so they both have the same secant line slope. The graph in (d) has $f(2) - f(-2) = 0$, and it is the only graph with this property, so it does not share its secant line slope with any of the other graphs.

S-4: A good approximation from the graph is $f(5) = 0.5$. We want to find a secant line whose endpoints are both very close to $x = 5$, but that also give us clear y -values. It looks like $f(5.25) \approx 1$, and $f(4.75) \approx \frac{1}{8}$. The secant line from $x = 5$ to $x = 5.25$ has approximate slope $\frac{f(5.25) - f(5)}{5.25 - 5} \approx \frac{1 - .5}{.25} = 2$. The secant line from $x = 5$ to $x = 4.75$ has approximate slope $\frac{0.5 - \frac{1}{8}}{5 - 4.75} = \frac{3}{2}$.

The graph increases more and more quickly (gets steeper and steeper), so it makes sense that the secant line to the left of $x = 5$ has a smaller slope than the secant line to the right of $x = 5$. Also, if you're taking secant lines that have endpoints farther out from $x = 5$, you'll notice that the slopes of the secant lines change quite dramatically. You have to be very, very close to $x = 5$ to get any kind of accuracy.

If we split the difference, we might approximate the slope of the secant line to be the average of $\frac{3}{2}$ and 2, which is $\frac{7}{4}$.

Another way to try to figure out the tangent line is by carefully drawing it in with a ruler. This is shown here in blue:

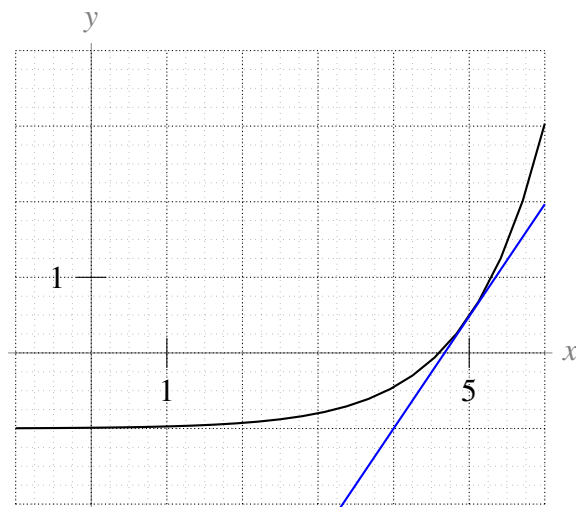

It's much easier to take the slope of a line than a curve, and this one looks like it has slope about 1.5. However, we drew this with a computer: by hand it's much harder to draw an accurate tangent line. (That's why we need calculus!)

The actual slope of the tangent line to the function at $x = 5$ is about 1.484. This is extremely hard to figure out just from the graph—by hand, a guess between 1.25 and 1.75 would be very accurate.

S-5: There is only one tangent line to $f(x)$ at P (shown in blue), but there are infinitely many choices of Q and R (one possibility shown in red). One easy way to sketch the secant line on paper is to draw any line parallel to the tangent line, and choose two intercepts with $y = f(x)$.

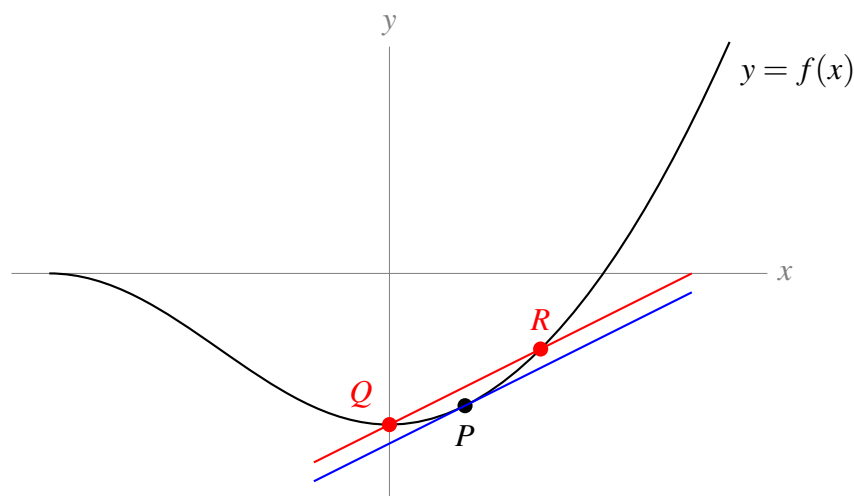

S-6: Any place the graph looks flat (if you imagine zooming in) is where the tangent line has slope 0. This occurs three times.

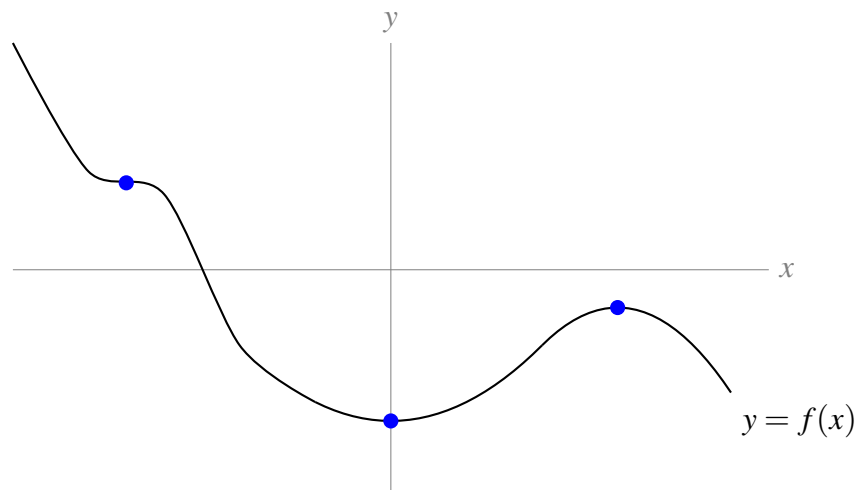

Notice that two of the indicated points are at a low point and a high point, respectively. Later, we'll use these places where the tangent line has slope zero to find where a graph achieves its biggest and smallest values.

Solutions to Exercises 3.3 — Jump to [TABLE OF CONTENTS](#)

S-1: The function shown is a line, so it has a constant slope—(a). Since the function is always increasing, f' is always positive, so also (d) holds. Remark: it does not matter that the function itself is sometimes negative; the slope is always positive because the function is always increasing. Also, since the slope is constant, f' is neither increasing nor decreasing: it is the *function* that is increasing, not its derivative.

S-2: The function is always decreasing, so f' is always negative, option (e). However, the function alternates between being more and less steep, so f' alternates between increasing and decreasing several times, and no other options hold.

Remark: f is always positive, but (d) does not hold!

S-3: At the left end of the graph, f is decreasing rapidly, so f' is a strongly negative number. Then as we move towards $x = 0$, f decreases less rapidly, so f' is a less strongly negative number. As we pass 0, f increases, so f' is a positive number. As we move to the right, f increases more and more rapidly, so f' is an increasing positive number. This description tells us that f' increases for the entire range shown. So (b) holds, but not (a) or (c). Since f' is negative to the left of the y axis, and positive to the right of it, also (d) and (e) do not hold.

S-4: By definition, $f(x) = x^3$ is differentiable at $x = 0$ if the limit

$$\lim_{h \rightarrow 0} \frac{f(h) - f(0)}{h} = \lim_{h \rightarrow 0} \frac{h^3 - 0}{h}$$

exists.

S-5: $f'(-1)$ does not exist, because to the left of $x = -1$ the slope is a pretty big positive number (looks like around $+1$) and to the right the slope is $-1/4$. Since the derivative involves a limit, that limit needs to match the limit from the left and the limit from the right. The sharp angle made by the graph at $x = -1$ indicates that the left and right limits do not match, so the derivative does not exist.

$f'(3)$ also does not exist. One way to see this is to notice that the function is discontinuous here. More viscerally, note that $f(3) = 1$, so as we take secant lines with one endpoint $(3, 1)$, and the other endpoint just to the right of $x = 3$, we get slopes that are more and more strongly negative, as shown in the picture below. If we take the limit of the slopes of these secant lines as x goes to 3 from the right, we get $-\infty$. (This certainly doesn't match the slope from the left, which is $-\frac{1}{4}$.)

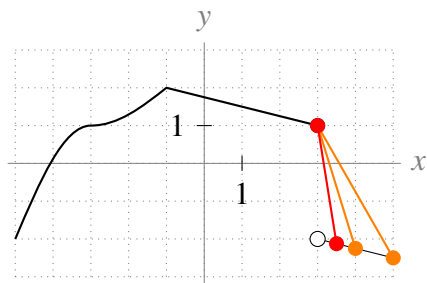

At $x = -3$, there is some kind of “change” in the graph; however, it is a smooth curve, so the derivative exists here.

S-6: True. The definition of the derivative tells us that

$$f'(a) = \lim_{h \rightarrow 0} \frac{f(a+h) - f(a)}{h},$$

if it exists. We know from our work with limits that if both one-sided limits

$\lim_{h \rightarrow 0^-} \frac{f(a+h) - f(a)}{h}$ and $\lim_{h \rightarrow 0^+} \frac{f(a+h) - f(a)}{h}$ exist and are equal to each other, then

$\lim_{h \rightarrow 0} \frac{f(a+h) - f(a)}{h}$ exists and has the same value as the one-sided limits. So, since the one-sided limits exist and are equal to one, we conclude $f'(a)$ exists and is equal to one.

S-7: In general, this is false. The key problem that can arise is that $f(x)$ might not be continuous at $x = 1$. One example is the function

$$f(x) = \begin{cases} x & x < 0 \\ x - 1 & x \geq 0 \end{cases}$$

where $f'(x) = 1$ whenever $x \neq 0$ (so in particular, $\lim_{x \rightarrow 0^-} f'(x) = \lim_{x \rightarrow 0^+} f'(x) = 1$) but $f'(0)$ does not exist.

There are two ways to see that $f'(0)$ does not exist. One is to notice that f is not continuous at $x = 0$.

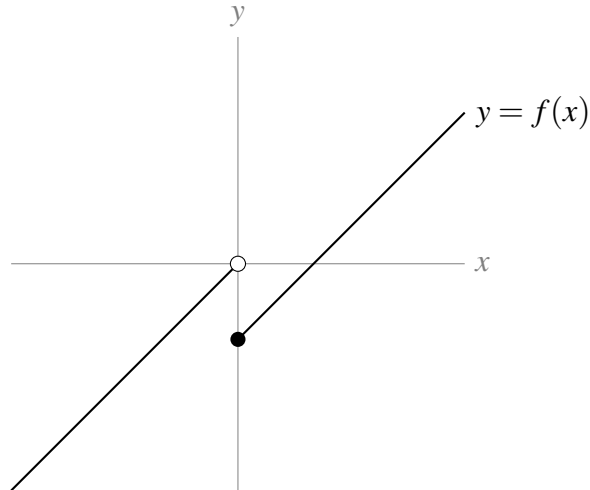

Another way to see that $f'(0)$ does not exist is to use the definition of the derivative. Remember, in order for a limit to exist, both one-sided limits must exist. Let's consider the limit from the left. If $h \rightarrow 0^-$, then $h < 0$, so $f(h)$ is equal to h (not $h - 1$).

$$\begin{aligned} \lim_{h \rightarrow 0^-} \frac{f(0+h) - f(0)}{h} &= \lim_{h \rightarrow 0^-} \frac{(h) - (-1)}{h} \\ &= \lim_{h \rightarrow 0^-} \frac{h+1}{h} \\ &= \lim_{h \rightarrow 0^-} 1 + \frac{1}{h} \\ &= -\infty \end{aligned}$$

In particular, this limit does not exist. Since the one-sided limit does not exist,

$$\lim_{h \rightarrow 0} \frac{f(0+h) - f(0)}{h} = DNE$$

and so $f'(0)$ does not exist.

S-8: Using the definition of the derivative,

$$s'(t) = \lim_{h \rightarrow 0} \frac{s(t+h) - s(t)}{h}$$

The units of the numerator are meters, and the units of the denominator are seconds (since the denominator comes from the change in the *input* of the function). So, the units of $s'(t)$ are metres per second.

Remark: we learned that the derivative of a position function gives velocity. In this example, the position is given in metres, and the velocity is measured in metres per second.

S-9: We can use point-slope form to get the equation of the line, if we have a point and its slope.

The point is given: (1,6). The slope is the derivative:

$$\begin{aligned}y'(1) &= \lim_{h \rightarrow 0} \frac{y(1+h) - y(1)}{h} \\&= \lim_{h \rightarrow 0} \frac{[(1+h)^3 + 5] - [1^3 + 5]}{h} \\&= \lim_{h \rightarrow 0} \frac{[1 + 3h + 3h^2 + h^3 + 5] - [1 + 5]}{h} \\&= \lim_{h \rightarrow 0} \frac{3h + 3h^2 + h^3}{h} \\&= \lim_{h \rightarrow 0} 3 + 3h + h^2 \\&= 3\end{aligned}$$

So our slope is 3, which gives a line of equation $y - 6 = 3(x - 1)$.

S-10: We set up the definition of the derivative.

$$\begin{aligned}f'(x) &= \lim_{h \rightarrow 0} \frac{f(x+h) - f(x)}{h} \\&= \lim_{h \rightarrow 0} \frac{\frac{1}{x+h} - \frac{1}{x}}{h} \\&= \lim_{h \rightarrow 0} \frac{\frac{x}{x(x+h)} - \frac{x+h}{x(x+h)}}{h} \\&= \lim_{h \rightarrow 0} \frac{\frac{x - (x+h)}{x(x+h)}}{h} \\&= \lim_{h \rightarrow 0} \frac{\frac{-h}{x(x+h)}}{h} \\&= \lim_{h \rightarrow 0} \frac{-1}{x(x+h)} \\&= \frac{-1}{x^2}\end{aligned}$$

S-11: By definition

$$f'(0) = \lim_{h \rightarrow 0} \frac{f(h) - f(0)}{h} = \lim_{h \rightarrow 0} \frac{h|h|}{h} = \lim_{h \rightarrow 0} |h| = 0$$

In particular, the limit exists, so the derivative exists (and is equal to zero).

S-12: We set up the definition of the derivative.

$$\begin{aligned}f'(x) &= \lim_{h \rightarrow 0} \frac{f(x+h) - f(x)}{h} = \lim_{h \rightarrow 0} \frac{1}{h} \left(\frac{2}{x+h+1} - \frac{2}{x+1} \right) = \lim_{h \rightarrow 0} \frac{2}{h} \frac{(x+1) - (x+h+1)}{(x+h+1)(x+1)} \\&= \lim_{h \rightarrow 0} \frac{2}{h} \frac{-h}{(x+h+1)(x+1)} = \lim_{h \rightarrow 0} \frac{-2}{(x+h+1)(x+1)} = \frac{-2}{(x+1)^2}\end{aligned}$$

S-13:

$$\begin{aligned} f'(x) &= \lim_{h \rightarrow 0} \frac{f(x+h) - f(x)}{h} = \lim_{h \rightarrow 0} \frac{1}{h} \left(\frac{1}{(x+h)^2 + 3} - \frac{1}{x^2 + 3} \right) = \lim_{h \rightarrow 0} \frac{1}{h} \frac{x^2 - (x+h)^2}{[(x+h)^2 + 3][x^2 + 3]} \\ &= \lim_{h \rightarrow 0} \frac{1}{h} \frac{-2xh - h^2}{[(x+h)^2 + 3][x^2 + 3]} = \lim_{h \rightarrow 0} \frac{-2x - h}{[(x+h)^2 + 3][x^2 + 3]} = \boxed{\frac{-2x}{[x^2 + 3]^2}} \end{aligned}$$

S-14: The slope of the tangent line is the derivative. We set this up using the same definition of the derivative that we always do. This limit is hard to take for general x , but easy when $x = 0$.

$$\begin{aligned} f'(0) &= \lim_{h \rightarrow 0} \frac{f(0+h) - f(0)}{h} \\ &= \lim_{h \rightarrow 0} \frac{h \log_{10}(2h+10) - 0}{h} \\ &= \lim_{h \rightarrow 0} \log_{10}(2h+10) = \log_{10}(10) = 1 \end{aligned}$$

So, the slope of the tangent line is 1.

S-15:

$$\begin{aligned} f'(x) &= \lim_{h \rightarrow 0} \frac{f(x+h) - f(x)}{h} = \lim_{h \rightarrow 0} \frac{\frac{1}{(x+h)^2} - \frac{1}{x^2}}{h} = \lim_{h \rightarrow 0} \frac{x^2 - (x+h)^2}{(x+h)^2 x^2 h} = \lim_{h \rightarrow 0} \frac{-2xh - h^2}{(x+h)^2 x^2 h} \\ &= \lim_{h \rightarrow 0} \frac{-2x - h}{(x+h)^2 x^2} = \frac{-2x}{x^4} = -\frac{2}{x^3} \end{aligned}$$

S-16: When x is not equal to 2, then the function is differentiable— the only place we have to worry about is when x is exactly 2.

In order for f to be differentiable at $x = 2$, it must also be continuous at $x = 2$. This forces

$$x^2|_{x=2} = [ax + b]_{x=2} \text{ or}$$

$$2a + b = 4.$$

In order for a limit to exist, the left- and right-hand limits must exist and be equal to each other. Since a derivative is a limit, in order for f to be differentiable at $x = 2$, the left hand derivative of $ax + b$ at $x = 2$ must be the same as the right hand derivative of x^2 at $x = 2$. Since $ax + b$ is a line, its derivative is a everywhere. We've already seen the derivative of x^2 is $2x$, so we need

$$a = 2x|_{x=2} = 4.$$

So, the values of a and b that makes f differentiable everywhere are $a = 4$ and $b = -4$.

S-17: We plug in $f(x)$ to the definition of a derivative. To evaluate the limit, we multiply and divide by the conjugate of the numerator, then simplify.

$$\begin{aligned}
 f'(x) &= \lim_{h \rightarrow 0} \frac{f(x+h) - f(x)}{h} = \lim_{h \rightarrow 0} \frac{\sqrt{1+x+h} - \sqrt{1+x}}{h} \\
 &= \lim_{h \rightarrow 0} \frac{\sqrt{1+x+h} - \sqrt{1+x}}{h} \left(\frac{\sqrt{1+x+h} + \sqrt{1+x}}{\sqrt{1+x+h} + \sqrt{1+x}} \right) \\
 &= \lim_{h \rightarrow 0} \frac{(1+x+h) - (1+x)}{h(\sqrt{1+x+h} + \sqrt{1+x})} \\
 &= \lim_{h \rightarrow 0} \frac{h}{h(\sqrt{1+x+h} + \sqrt{1+x})} \\
 &= \lim_{h \rightarrow 0} \frac{1}{\sqrt{1+x+h} + \sqrt{1+x}} \\
 &= \frac{1}{\sqrt{1+x+0} + \sqrt{1+x}} = \frac{1}{2\sqrt{1+x}}
 \end{aligned}$$

The domain of the function is $[-1, \infty)$. In particular, $f(x)$ is defined when $x = -1$. However, $f'(x)$ is not defined when $x = -1$, so $f'(x)$ only exists over $(-1, \infty)$.

Remark: $\lim_{x \rightarrow -1^+} f'(x) = \infty$, so the tangent line to $f(x)$ at the point $x = -1$ has a vertical slope.

S-18: Recall the velocity is exactly the derivative.

$$\begin{aligned}
 v(t) &= \lim_{h \rightarrow 0} \frac{s(t+h) - s(t)}{h} \\
 &= \lim_{h \rightarrow 0} \frac{(t+h)^4 - (t+h)^2 - t^4 + t^2}{h} \\
 &= \lim_{h \rightarrow 0} \frac{(t^4 + 4t^3h + 6t^2h^2 + 4th^3 + h^4) - (t^2 + 2th + h^2) - t^4 + t^2}{h} \\
 &= \lim_{h \rightarrow 0} \frac{4t^3h + 6t^2h^2 + 4th^3 + h^4 - 2th - h^2}{h} \\
 &= \lim_{h \rightarrow 0} 4t^3 + 6t^2h + 4th^2 + h^3 - 2t - h \\
 &= 4t^3 - 2t
 \end{aligned}$$

So, the velocity is given by $v(t) = 4t^3 - 2t$.

S-19: The function is differentiable at $x = 0$ if the following limit:

$$\lim_{x \rightarrow 0} \frac{f(x) - f(0)}{x - 0} = \lim_{x \rightarrow 0} \frac{f(x) - 0}{x} = \lim_{x \rightarrow 0} \frac{f(x)}{x}$$

exists (note that we used the fact that $f(0) = 0$ as per the definition of the first branch which includes the point $x = 0$). We start by computing the left limit. For this computation, recall that if $x < 0$ then $\sqrt{x^2} = |x| = -x$.

$$\lim_{x \rightarrow 0^-} \frac{f(x)}{x} = \lim_{x \rightarrow 0^-} \frac{\sqrt{x^2 + x^4}}{x} = \lim_{x \rightarrow 0^-} \frac{\sqrt{x^2} \sqrt{1+x^2}}{x} = \lim_{x \rightarrow 0^-} \frac{-x \sqrt{1+x^2}}{x} = -1$$

Now, from the right:

$$\lim_{x \rightarrow 0^+} \frac{x \cos x}{x} = \lim_{x \rightarrow 0^+} \cos x = 1.$$

Since the limit from the left does not equal the limit from the right, the derivative does not exist at $x = 0$.

S-20: The function is differentiable at $x = 0$ if the following limit:

$$\lim_{x \rightarrow 0} \frac{f(x) - f(0)}{x - 0} = \lim_{x \rightarrow 0} \frac{f(x) - 0}{x} = \lim_{x \rightarrow 0} \frac{f(x)}{x}$$

exists (note that we used the fact that $f(0) = 0$ as per the definition of the first branch which includes the point $x = 0$).

We start by computing the left limit.

$$\lim_{x \rightarrow 0^-} \frac{f(x)}{x} = \lim_{x \rightarrow 0^-} \frac{x \cos x}{x} = \lim_{x \rightarrow 0^-} \cos x = 1.$$

Now, from the right:

$$\begin{aligned} \lim_{x \rightarrow 0^+} \frac{\sqrt{1+x} - 1}{x} &= \lim_{x \rightarrow 0^+} \frac{\sqrt{1+x} - 1}{x} \cdot \frac{\sqrt{1+x} + 1}{\sqrt{1+x} + 1} \\ &= \lim_{x \rightarrow 0^+} \frac{1+x-1}{x(\sqrt{1+x}+1)} = \lim_{x \rightarrow 0^+} \frac{1}{\sqrt{1+x}+1} = \frac{1}{2} \end{aligned}$$

Since the limit from the left does not equal the limit from the right, the derivative does not exist at $x = 0$.

S-21: The function is differentiable at $x = 0$ if the following limit:

$$\lim_{x \rightarrow 0} \frac{f(x) - f(0)}{x - 0} = \lim_{x \rightarrow 0} \frac{f(x) - 0}{x} = \lim_{x \rightarrow 0} \frac{f(x)}{x}$$

exists (note that we used the fact that $f(0) = 0$ as per the definition of the first branch which includes the point $x = 0$). We compute left and right limits; so

$$\lim_{x \rightarrow 0^-} \frac{f(x)}{x} = \lim_{x \rightarrow 0^-} \frac{x^3 - 7x^2}{x} = \lim_{x \rightarrow 0^-} x^2 - 7x = 0$$

and

$$\lim_{x \rightarrow 0^+} \frac{x^3 \cos\left(\frac{1}{x}\right)}{x} = \lim_{x \rightarrow 0^+} x^2 \cdot \cos\left(\frac{1}{x}\right).$$

This last limit equals 0 (see Question 23 in 2.1.1 for a similar example).

Since the left and right limits match (they're both equal to 0), we conclude that indeed $f(x)$ is differentiable at $x = 0$ (and its derivative at $x = 0$ is actually equal to 0).

S-22: The function is differentiable at $x = 1$ if the following limit:

$$\lim_{x \rightarrow 1} \frac{f(x) - f(1)}{x - 1} = \lim_{x \rightarrow 1} \frac{f(x) - 0}{x - 1} = \lim_{x \rightarrow 1} \frac{f(x)}{x - 1}$$

exists (note that we used the fact that $f(1) = 0$ as per the definition of the first branch which includes the point $x = 0$). We compute left and right limits; so

$$\lim_{x \rightarrow 1^-} \frac{f(x)}{x - 1} = \lim_{x \rightarrow 1^-} \frac{4x^2 - 8x + 4}{x - 1} = \lim_{x \rightarrow 1^-} \frac{4(x - 1)^2}{x - 1} = \lim_{x \rightarrow 1^-} 4(x - 1) = 0$$

and

$$\lim_{x \rightarrow 1^+} \frac{(x - 1)^2 \sin\left(\frac{1}{x - 1}\right)}{x - 1} = \lim_{x \rightarrow 1^+} (x - 1) \cdot \sin\left(\frac{1}{x - 1}\right).$$

For this last limit, note that $|\sin\left(\frac{1}{x - 1}\right)| \leq 1$, so $|(x - 1) \cdot \sin\left(\frac{1}{x - 1}\right)| \leq |x - 1|$. That is, the ‘sine’ part of the product can only make the $(x - 1)$ part *closer* to 0, not farther from 0. Since $\lim_{x \rightarrow 1^+} (x - 1) = 0$, then also $\lim_{x \rightarrow 1^+} (x - 1) \cdot \sin\left(\frac{1}{x - 1}\right) = 0$.

Since the left and right limits match (they’re both equal to 0), we conclude that indeed $f(x)$ is differentiable at $x = 1$ (and its derivative at $x = 1$ is actually equal to 0).

S-23: Many answers are possible; here is one.

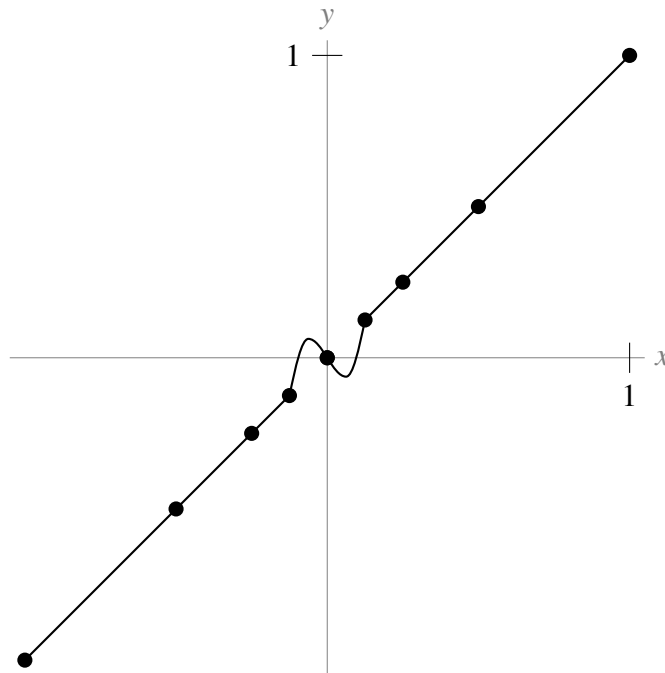

The key is to realize that the few points you’re given suggest a pattern, but don’t guarantee it. You only know nine points; anything can happen in between.

S-24:

$$\begin{aligned} p'(x) &= \lim_{h \rightarrow 0} \frac{p(x+h) - p(x)}{h} \\ &= \lim_{h \rightarrow 0} \frac{f(x+h) + g(x+h) - f(x) - g(x)}{h} \\ &= \lim_{h \rightarrow 0} \frac{f(x+h) - f(x) + g(x+h) - g(x)}{h} \\ &= \lim_{h \rightarrow 0} \left[\frac{f(x+h) - f(x)}{h} + \frac{g(x+h) - g(x)}{h} \right] \\ (*) &= \left[\lim_{h \rightarrow 0} \frac{f(x+h) - f(x)}{h} \right] + \left[\lim_{h \rightarrow 0} \frac{g(x+h) - g(x)}{h} \right] \\ &= f'(x) + g'(x) \end{aligned}$$

At step (*), we use the limit law that $\lim_{x \rightarrow a} [F(x) + G(x)] = \lim_{x \rightarrow a} F(x) + \lim_{x \rightarrow a} G(x)$, as long as $\lim_{x \rightarrow a} F(x)$ and $\lim_{x \rightarrow a} G(x)$ exist. Because the problem states that $f'(x)$ and $g'(x)$ exist, we know that $\lim_{h \rightarrow 0} \frac{f(x+h) - f(x)}{h}$ and $\lim_{h \rightarrow 0} \frac{g(x+h) - g(x)}{h}$ exist, so our work is valid.

S-25: (a) Since $y = f(x) = 2x$ and $y = g(x) = x$ are straight lines, we don't need the definition of the derivative (although you can use it if you like). $f'(x) = 2$ and $g'(x) = 1$.

(b) $p(x) = 2x^2$, so $p(x)$ is not a line: we use the definition of a derivative to find $p'(x)$.

$$\begin{aligned} p'(x) &= \lim_{h \rightarrow 0} \frac{p(x+h) - p(x)}{h} \\ &= \lim_{h \rightarrow 0} \frac{2(x+h)^2 - 2x^2}{h} \\ &= \lim_{h \rightarrow 0} \frac{2x^2 + 4xh + 2h^2 - 2x^2}{h} \\ &= \lim_{h \rightarrow 0} \frac{4xh + 2h^2}{h} \\ &= \lim_{h \rightarrow 0} 4x + 2h \\ &= 4x \end{aligned}$$

(c) No, $p'(x) = 4x \neq 2 \cdot 1 = f'(x) \cdot g'(x)$. In general, the derivative of a product is not the same as the derivative of the functions being multiplied.

S-26: We know that $y' = 2x$. So, if we choose a point (α, α^2) on the curve $y = x^2$, then the tangent line to the curve at that point has slope 2α . That is, the tangent line has equation

$$\begin{aligned} (y - \alpha^2) &= 2\alpha(x - \alpha) \\ \text{simplified, } y &= (2\alpha)x - \alpha^2 \end{aligned}$$

So, if $(1, -3)$ is on the tangent line, then

$$\begin{aligned} -3 &= (2\alpha)(1) - \alpha^2 \\ \iff 0 &= \alpha^2 - 2\alpha - 3 \\ \iff 0 &= (\alpha - 3)(\alpha + 1) \\ \iff \alpha &= 3, \quad \text{or} \quad \alpha = -1. \end{aligned}$$

So, the tangent lines $y = (2\alpha)x - \alpha^2$ are

$$y = 6x - 9 \quad \text{and} \quad y = -2x - 1.$$

S-27: Using the definition of the derivative, f is differentiable at 0 if and only if

$$\lim_{h \rightarrow 0} \frac{f(h) - f(0)}{h}$$

exists. In particular, this means f is differentiable at 0 if and only if both one-sided limits exist and are equal to each other.

When $h < 0$, $f(h) = 0$, so

$$\lim_{h \rightarrow 0^-} \frac{f(h) - f(0)}{h} = \lim_{h \rightarrow 0^-} \frac{0 - 0}{h} = 0$$

So, f is differentiable at $x = 0$ if and only if

$$\lim_{h \rightarrow 0^+} \frac{f(h) - f(0)}{h} = 0.$$

To evaluate the limit above, we note $f(0) = 0$ and, when $h > 0$, $f(h) = h^a \sin\left(\frac{1}{h}\right)$, so

$$\begin{aligned} \lim_{h \rightarrow 0^+} \frac{f(h) - f(0)}{h} &= \lim_{h \rightarrow 0^+} \frac{h^a \sin\left(\frac{1}{h}\right)}{h} \\ &= \lim_{h \rightarrow 0^+} h^{a-1} \sin\left(\frac{1}{h}\right) \end{aligned}$$

We will spend the rest of this solution evaluating the limit above for different values of a , to find when it is equal to zero and when it is not. Let's consider the different values that could be taken by h^{a-1} .

- If $a = 1$, then $a - 1 = 0$, so $h^{a-1} = h^0 = 1$ for all values of h . Then

$$\lim_{h \rightarrow 0^+} h^{a-1} \sin\left(\frac{1}{h}\right) = \lim_{h \rightarrow 0^+} \sin\left(\frac{1}{h}\right) = DNE$$

(Recall that the function $\sin\left(\frac{1}{x}\right)$ oscillates faster and faster as x goes to 0. We first saw this behaviour in Example 2.1.5 in the text.)

- If $a < 1$, then $a - 1 < 0$, so $\lim_{h \rightarrow 0^+} h^{a-1} = \infty$. (Since we have a negative exponent, we are in effect *dividing by* a smaller and smaller positive number. For example, if $a = \frac{1}{2}$, then $\lim_{h \rightarrow 0^+} h^{a-1} = \lim_{h \rightarrow 0^+} h^{-\frac{1}{2}} = \lim_{h \rightarrow 0^+} \frac{1}{\sqrt{h}} = \infty$.) Since $\sin\left(\frac{1}{x}\right)$ goes back and forth between one and negative one,

$$\lim_{h \rightarrow 0^+} h^{a-1} \sin\left(\frac{1}{x}\right) = DNE$$

since as h goes to 0, the function oscillates between positive and negative numbers of ever-increasing magnitude.

- If $a > 1$, then $a - 1 > 0$, so $\lim_{h \rightarrow 0^+} h^{a-1} = 0$. Although $\sin\left(\frac{1}{x}\right)$ oscillates wildly near $x = 0$, it is bounded by -1 and 1 . So, it can't stop the 'going to zero' behaviour of h^{a-1} . (Indeed, $h^{a-1} \sin\left(\frac{1}{x}\right)$ is either equal to h^{a-1} , or *even closer to 0* than h^{a-1} alone.) So,

$$\lim_{h \rightarrow 0^+} h^{a-1} \sin\left(\frac{1}{h}\right) = 0.$$

In the above cases, we learned

$$\lim_{h \rightarrow 0^+} \frac{f(h) - f(0)}{h} = \lim_{h \rightarrow 0^+} h^{a-1} \sin\left(\frac{1}{x}\right) = 0 \text{ when } a > 1, \text{ and}$$

$$\lim_{h \rightarrow 0^+} \frac{f(h) - f(0)}{h} = \lim_{h \rightarrow 0^+} h^{a-1} \sin\left(\frac{1}{x}\right) \neq 0 \text{ when } a \leq 1.$$

So, f is differentiable at $x = 0$ if and only if $a > 1$.

Solutions to Exercises 3.3 — Jump to [TABLE OF CONTENTS](#)

S-28: (a) The slope of the secant line is $\frac{h(24) - h(0)}{24 - 0} \frac{\text{m}}{\text{hr}}$; this is the change in height over the first day divided by the number of hours in the first day. So, it is the average rate of change of the height over the first day, measured in meters per hour.

(b) Consider (a). The secant line gives the *average* rate of change of the height of the dam; as we let the second point of the secant line get closer and closer to $(0, h(0))$, its slope approximates the instantaneous rate of change of the height of the water. So the slope of the tangent line is the instantaneous rate of change of the height of the water at the time $t = 0$, measured in $\frac{\text{m}}{\text{hr}}$.

S-29: $p'(t) = \lim_{h \rightarrow 0} \frac{p(t+h) - p(t)}{h} \approx \frac{p(t+1) - p(t)}{1} = p(t+1) - p(t)$, or the difference in profit caused by the sale of the $(t+1)^{\text{st}}$ widget. So, $p'(t)$ is the profit from the $(t+1)^{\text{st}}$ widget. That is, $p'(t)$ is the profit per additional widget sold, when t widgets are being sold. This is called the marginal profit per widget, when t widgets are being sold.

S-30: How quickly the temperature is changing per unit change of depth, measured in degrees per metre. In an ordinary body of water, the temperature near the surface ($d = 0$) is pretty variable,

depending on the sun, but deep down it is more stable (unless there are heat sources). So, one might reasonably expect that $|T'(d)|$ is larger when d is near 0.

S-31: $C'(w) = \lim_{h \rightarrow 0} \frac{C(w+h) - C(w)}{h} \approx \frac{C(w+1) - C(w)}{1} = C(w+1) - C(w)$, which is the number of calories in $C(w+1)$ grams minus the number of calories in $C(w)$ grams. This is the number of calories per additional gram, when there are w grams.

S-32: The rate of change of velocity is acceleration. (If your velocity is increasing, you're accelerating; if your velocity is decreasing, you have negative acceleration.)

S-33: The rate of change in this case will be the relationship between the heat added and the temperature change. $\lim_{h \rightarrow 0} \frac{T(j+h) - T(j)}{h} \approx \frac{T(j+1) - T(j)}{1} = T(j+1) - T(j)$, or the change in temperature after the application of one joule. (This is closely related to heat capacity and to specific heat — there's a nice explanation of this on Wikipedia.)

S-34: As usual, it is instructive to think about the definition of the derivative:

$$P'(T) = \lim_{h \rightarrow 0} \frac{P(T+h) - P(T)}{h} \approx \frac{P(T+1) - P(T)}{1} = P(T+1) - P(T).$$

This is the difference in population between two hypothetical populations, raised one degree in temperature apart. So, it is the number of extra individuals that exist in the hotter experiment (with the understanding that this number could be negative, as one would expect in conditions that are hotter than the bacteria prefer). So $P'(T)$ is the number of bacteria added to the colony per degree.

S-35: $R'(t)$ is the rate at which the wheel is rotating measured in rotations per second. To convert to degrees, we multiply by 360: $\boxed{360R'(t)}$.

S-36: If $P'(t)$ is positive, your sample is below the ideal temperature, because adding heat increases the population. If $P'(t)$ is negative, your sample is above the ideal temperature, because adding heat decreases the population. If $P'(t) = 0$, then adding a little bit of heat doesn't change the population, but it's unclear why this is. Perhaps your sample is deeply frozen, and adding heat doesn't change the fact that your population is 0. Perhaps your sample is boiling, and again, changing the heat a little will keep the population constant at "none." But also, at the ideal temperature, you would expect $P'(t) = 0$. This is best seen by noting in the curve below, the tangent line is horizontal at the peak.

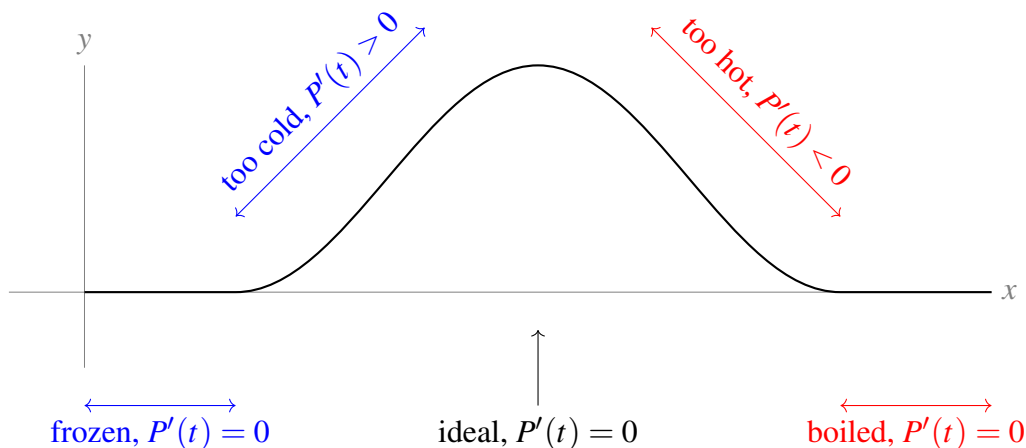

Solutions to Exercises 3.4 — Jump to [TABLE OF CONTENTS](#)

S-1: Since $f'(x) < 0$, we need a decreasing function. This only applies to (ii), (iii), and (v). Since $f''(x) > 0$, that means $f'(x)$ is increasing, so the *slope* of the function must be increasing. In (v), the slope is constant, so $f''(x) = 0$ —therefore, it's not (v). In (iii), the slope is decreasing, because near a the curve is quite flat ($f'(x)$ near zero) but near b the curve is very steeply decreasing ($f'(x)$ is a large *negative* number), so (iii) has a negative second derivative. By contrast, in (ii), the line starts out as steeply decreasing ($f'(x)$ is a strongly negative number) and becomes flatter and flatter ($f'(x)$ nears 0), so $f'(x)$ is increasing—in other words, $f''(x) > 0$. So, (ii) is the only curve that has $f'(x) < 0$ and $f''(x) > 0$.

Solutions to Exercises 3.5 — Jump to [TABLE OF CONTENTS](#)

S-1: Since $1^x = 1$ for any x , we see that (b) is just the constant function $y = 1$, so D matches to (b).

Since $2^{-x} = \frac{1}{2^x} = \left(\frac{1}{2}\right)^x$, functions (a) and (d) are the same. This is the only function out of the lot that grows as $x \rightarrow -\infty$ and shrinks as $x \rightarrow \infty$, so A matches to (a) and (d).

This leaves B and C to match to (c) and (e). Since $3 > 2$, when $x > 0$, $3^x > 2^x$. So, (e) matches to the function that grows more quickly to the right of the x -axis: B matches to (e), and C matches to (c).

S-2: First, let's consider the behaviour of exponential functions a^x based on whether a is greater or less than 1. As we know, $\lim_{x \rightarrow \infty} a^x = \begin{cases} \infty & a > 1 \\ 0 & a < 1 \end{cases}$ and $\lim_{x \rightarrow -\infty} a^x = \begin{cases} 0 & a > 1 \\ \infty & a < 1 \end{cases}$. Our function has $\lim_{x \rightarrow \infty} f(x) = \infty$ and $\lim_{x \rightarrow -\infty} f(x) = 0$, so we conclude $a > 1$: thus (d) and also (b) hold. (We could have also seen that (b) holds because a^x is defined for all real numbers.)

It remains to decide whether a is greater or less than e . (If a were equal to e , then $f'(x)$ would be the same as $f(x)$.) We saw in the text that $\frac{d}{dx}\{a^x\} = C(a)a^x$ for the function $C(a) = \lim_{h \rightarrow 0} \frac{a^h - 1}{h}$.

We know that $C(e) = 1$. (Actually, we chose e to be the number that has this property.) From our graph, we see that $f'(x) < f(x)$, so $C(a) < 1 = C(e)$. In other words, $\lim_{h \rightarrow 0} \frac{a^h - 1}{h} < \lim_{h \rightarrow 0} \frac{e^h - 1}{h}$; so, $a < e$. Thus (e) holds.

S-3: The power rule tells us that $\frac{d}{dx}\{x^n\} = nx^{n-1}$. In this equation, the variable is the base, and the exponent is a constant. In the function e^x , it's reversed: the variable is the exponent, and the base is a constant. So, the power rule does not apply.

S-4: $P(t)$ is an increasing function over its domain, so the population is increasing.

There are a few ways to see that $P(t)$ is increasing.

What we really care about is whether $e^{0.2t}$ is increasing or decreasing, since an increasing function multiplied by 100 is still an increasing function, and a decreasing function multiplied by 100 is still a decreasing function. Since $f(t) = e^t$ is an increasing function, we can use what we know about graphing functions to see that $f(0.2t) = e^{0.2t}$ is also increasing.

S-5: The derivative of e^x is e^x : taking derivatives leaves the function unchanged, even if we do it 180 times. So $f^{(180)} = e^x$.

S-6: We simplify the functions to get a better idea of what's going on.

(a): $y = e^{3 \log x} + 1 = (e^{\log x})^3 + 1 = x^3 + 1$. This is not a line.

(b): $2y + 5 = e^{3 + \log x} = e^3 e^{\log x} = e^3 x$. Since e^3 is a constant, $2y + 5 = e^3 x$ is a line.

(c): There isn't a fancy simplification here—this isn't a line. If that isn't a satisfactory answer, we can check: a line is a function with a constant slope. For our function, $y' = \frac{d}{dx}\{e^{2x} + 4\} = \frac{d}{dx}\{e^{2x}\} = \frac{d}{dx}\{(e^x)^2\} = 2e^x e^x = 2e^{2x}$. Since the derivative isn't constant, the function isn't a line.

(d): $y = e^{\log x} 3^e + \log 2 = 3^e x + \log 2$. Since 3^e and $\log 2$ are constants, this is a line.

Solutions to Exercises 4.1 — Jump to [TABLE OF CONTENTS](#)

S-1: True: this is exactly what the Sum Rule states.

S-2: False, in general. The product rule tells us $\frac{d}{dx}\{f(x)g(x)\} = f'(x)g(x) + f(x)g'(x)$. An easy example of why we can't do it the other way is to take $f(x) = g(x) = x$. Then the equation becomes $\frac{d}{dx}\{x^2\} = (1)(1)$, which is false.

S-3: True: the quotient rule tells us

$$\frac{d}{dx} \left\{ \frac{f(x)}{g(x)} \right\} = \frac{g(x)f'(x) - f(x)g'(x)}{g^2(x)} = \frac{g(x)f'(x)}{g^2(x)} - \frac{f(x)g'(x)}{g^2(x)} = \frac{f'(x)}{g(x)} - \frac{f(x)g'(x)}{g^2(x)}.$$

S-4: If you're creative, you can find lots of ways to differentiate!

Constant multiple: $g'(x) = 3f'(x)$.

Product rule: $g'(x) = \frac{d}{dx}\{3\}f(x) + 3f'(x) = 0f(x) + 3f'(x) = 3f'(x)$.

Sum rule: $g'(x) = \frac{d}{dx}\{f(x) + f(x) + f(x)\} = f'(x) + f'(x) + f'(x) = 3f'(x)$.

Quotient rule: $g'(x) = \frac{d}{dx}\left\{\frac{f(x)}{\frac{1}{3}}\right\} = \frac{\frac{1}{3}f'(x) - f(x)(0)}{\frac{1}{9}} = \frac{\frac{1}{3}f'(x)}{\frac{1}{9}} = 9\left(\frac{1}{3}\right)f'(x) = 3f'(x)$.

All rules give $g'(x) = 3f'(x)$.

S-5: We know, from Examples 3.3.10 and 3.3.14 in the text, that $\frac{d}{dx}x^2 = 2x$ and $\frac{d}{dx}x^{1/2} = \frac{1}{2\sqrt{x}}$. So, by linearity,

$$f'(x) = 3 \cdot 2x + 4 \cdot \frac{1}{2\sqrt{x}} = 6x + \frac{2}{\sqrt{x}}$$

S-6: We differentiate a few time to find the pattern.

$$\begin{aligned}\frac{d}{dx}\{2^x\} &= 2^x \log 2 \\ \frac{d^2}{dx^2}\{2^x\} &= 2^x \log 2 \cdot \log 2 = 2^x (\log 2)^2 \\ \frac{d^3}{dx^3}\{2^x\} &= 2^x (\log 2)^2 \cdot \log 2 = 2^x (\log 2)^3\end{aligned}$$

Every time we differentiate, we multiply the original function by another factor of $\log 2$. So, the n th derivative is given by:

$$\frac{d^n}{dx^n}\{2^x\} = 2^x (\log 2)^n$$

S-7: We have already seen $\frac{d}{dx}\{\sqrt{x}\} = \frac{1}{2\sqrt{x}}$ in Example 3.3.14 of the text. Now:

$$\begin{aligned}f'(x) &= (2)(8\sqrt{x} - 9x) + (2x + 5)\left(\frac{8}{2\sqrt{x}} - 9\right) \\ &= 16\sqrt{x} - 18x + (2x + 5)\left(\frac{4}{\sqrt{x}} - 9\right) \\ &= -36x + 24\sqrt{x} + \frac{20}{\sqrt{x}} - 45\end{aligned}$$

S-8: We already know that $\frac{d}{dx}x = 1$ and $\frac{d}{dx}x^2 = 2x$, so we can compute the derivative of x^3 by writing $x^3 = (x)(x^2)$,

$$\frac{d}{dx}x^3 = \frac{d}{dx}(x)(x^2) = (1)(x^2) + (x)(2x) = 3x^2$$

When this is evaluated at $x = \frac{1}{2}$ we get $\frac{3}{4}$. Since we also compute $(\frac{1}{2})^3 = \frac{1}{8}$, the equation of the tangent line is

$$y - \frac{1}{8} = \frac{3}{4} \cdot \left(x - \frac{1}{2}\right).$$

S-9: Let $f(t) = t^3 - 4t^2 + 1$. We saw in Question 8 that $\frac{d}{dt}t^3 = 3t^2$. So

$$\begin{aligned} f'(t) &= 3t^2 - 8t & f'(2) &= 3 \times 4 - 8 \times 2 = -4 \\ f''(t) &= 6t - 8 & f''(2) &= 6 \times 2 - 8 = 4 \end{aligned}$$

Hence at $t = 2$, (a) the particle has speed of magnitude 4, and (b) is moving towards the left. At $t = 2$, $f''(2) > 0$, so f' is increasing, i.e. becoming less negative. Since f' is getting closer to zero, (c) the magnitude of the speed is decreasing.

S-10: We can use the quotient rule here.

$$\frac{d}{dx} \left\{ \frac{2x-1}{2x+1} \right\} = \frac{(2x+1)(2) - (2x-1)(2)}{(2x+1)^2} = \frac{4}{(2x+1)^2} = \frac{1}{(x+1/2)^2}$$

S-11: First, we find the y' for general x . Using the corollary to Theorem 4.1.3 and the quotient rule:

$$\begin{aligned} y' &= 2 \left(\frac{3x+1}{3x-2} \right) \cdot \frac{d}{dx} \left\{ \frac{3x+1}{3x-2} \right\} \\ &= 2 \left(\frac{3x+1}{3x-2} \right) \left(\frac{(3x-2)(3) - (3x+1)(3)}{(3x-2)^2} \right) \\ &= 2 \left(\frac{3x+1}{3x-2} \right) \left(\frac{-9}{(3x-2)^2} \right) \\ &= \frac{-18(3x+1)}{(3x-2)^3} \end{aligned}$$

So, plugging in $x = 1$:

$$y'(1) = \frac{-18(3+1)}{(3-2)^3} = -72$$

S-12: Using the product rule, $g'(x) = f'(x)e^x + f(x)e^x = [f(x) + f'(x)]e^x$

S-13: Population growth is rate of change of population. Population in year 2000 + t is given by $P(t) = P_0 + b(t) - d(t)$, where P_0 is the initial population of the town. Then $P'(t)$ is the expression we're looking for, and $P'(t) = b'(t) - d'(t)$.

It is interesting to note that the initial population does not obviously show up in this calculation. It would probably affect $b(t)$ and $d(t)$, but if we know these we do not need to know P_0 to answer our question.

S-14: We already know that $\frac{d}{dx}x^2 = 2x$. So the slope of $y = 3x^2$ at $x = a$ is $6a$. The tangent line to $y = 3x^2$ at $x = a, y = 3a^2$ is $y - 3a^2 = 6a(x - a)$. This tangent line passes through $(2, 9)$ if

$$\begin{aligned}9 - 3a^2 &= 6a(2 - a) \\3a^2 - 12a + 9 &= 0 \\a^2 - 4a + 3 &= 0 \\(a - 3)(a - 1) &= 0 \\ \implies a &= 1, 3\end{aligned}$$

The points are $(1, 3)$, $(3, 27)$.

S-15: This limit represents the derivative computed at $x = 100180$ of the function $f(x) = \sqrt{x}$. Since the derivative of $f(x)$ is $\frac{1}{2\sqrt{x}}$, then its value at $x = 100180$ is exactly $\frac{1}{2\sqrt{100180}}$.

S-16: Let $w(t)$ and $l(t)$ be the width and length of the rectangle. Given in the problem is that $w'(t) = 2$ and $l'(t) = 5$. Since both functions have constant slopes, both must be lines. Their slopes are given, and their intercepts are $w(0) = l(0) = 1$. So, $w(t) = 2t + 1$ and $l(t) = 5t + 1$.

The area of the rectangle is $A(t) = w(t) \cdot l(t)$, so using the product rule, the rate at which the area is increasing is $A'(t) = w'(t)l(t) + w(t)l'(t) = 2(5t + 1) + 5(2t + 1) = 20t + 7$ square metres per second.

S-17: Using the product rule, $f'(x) = (2x)g(x) + x^2g'(x)$, so $f'(0) = 0 \cdot g(0) + 0 \cdot g'(0) = 0$. (Since g is differentiable, g' exists.)

S-18:

First expression, $f(x) = \frac{g(x)}{h(x)}$:

$$f'(x) = \frac{h(x)g'(x) - g(x)h'(x)}{h^2(x)}$$

Second expression, $f(x) = \frac{g(x)}{k(x)} \cdot \frac{k(x)}{h(x)}$:

$$\begin{aligned}
 f'(x) &= \left(\frac{k(x)g'(x) - g(x)k'(x)}{k^2(x)} \right) \left(\frac{k(x)}{h(x)} \right) + \left(\frac{g(x)}{k(x)} \right) \left(\frac{h(x)k'(x) - k(x)h'(x)}{h^2(x)} \right) \\
 &= \frac{k(x)g'(x) - g(x)k'(x)}{k(x)h(x)} + \frac{g(x)h(x)k'(x) - g(x)k(x)h'(x)}{k(x)h^2(x)} \\
 &= \frac{h(x)k(x)g'(x) - h(x)g(x)k'(x)}{k(x)h^2(x)} + \frac{g(x)h(x)k'(x) - g(x)k(x)h'(x)}{k(x)h^2(x)} \\
 &= \frac{h(x)k(x)g'(x) - h(x)g(x)k'(x) + g(x)h(x)k'(x) - g(x)k(x)h'(x)}{k(x)h^2(x)} \\
 &= \frac{h(x)k(x)g'(x) - g(x)k(x)h'(x)}{k(x)h^2(x)} \\
 &= \frac{h(x)g'(x) - g(x)h'(x)}{h^2(x)}
 \end{aligned}$$

and this is exactly what we got from differentiating the first expression.

S-19: When we say a function is differentiable without specifying a range, we mean that it is differentiable over its domain. The function $f(x)$ is differentiable when $x \neq 1$ for any values of a and b ; it is up to us to figure out which constants make it differentiable when $x = 1$.

In order to be differentiable, a function must be continuous. The definition of continuity tells us that, for f to be continuous at $x = 1$, we need $\lim_{x \rightarrow 1} f(x) = f(1)$. From the definition of f , we see

$f(1) = a + b = \lim_{x \rightarrow 1^-} f(x)$, so we need $\lim_{x \rightarrow 1^+} f(x) = a + b$. Since $\lim_{x \rightarrow 1^+} f(x) = e^1 = e$, we specifically need

$$e = a + b.$$

Now, let's consider differentiability of f at $x = 1$. We need the following limit to exist:

$$\lim_{h \rightarrow 0} \frac{f(1+h) - f(1)}{h}$$

In particular, we need the one-sided limits to exist and be equal:

$$\lim_{h \rightarrow 0^-} \frac{f(1+h) - f(1)}{h} = \lim_{h \rightarrow 0^+} \frac{f(1+h) - f(1)}{h}$$

If $h < 0$, then $1 + h < 1$, so $f(1+h) = a(1+h)^2 + b$. If $h > 0$, then $1 + h > 1$, so $f(1+h) = e^{1+h}$. With this in mind, we begin to evaluate the one-sided limits:

$$\begin{aligned}
 \lim_{h \rightarrow 0^-} \frac{f(1+h) - f(1)}{h} &= \lim_{h \rightarrow 0^-} \frac{[a(1+h)^2 + b] - [a + b]}{h} \\
 &= \lim_{h \rightarrow 0^-} \frac{ah^2 + 2ah}{h} = 2a \\
 \lim_{h \rightarrow 0^+} \frac{f(1+h) - f(1)}{h} &= \lim_{h \rightarrow 0^+} \frac{e^{1+h} - (a + b)}{h}
 \end{aligned}$$

Since we take $a + b$ to be equal to e (to ensure continuity):

$$\begin{aligned} &= \lim_{h \rightarrow 0^+} \frac{e^{1+h} - e^1}{h} \\ &= \left. \frac{d}{dx} \{e^x\} \right|_{x=1} = e^1 = e \end{aligned}$$

So, we also need

$$2a = e$$

Therefore, the values of a and b that make f differentiable are $a = b = \frac{e}{2}$.

S-20: (a) Using the product rule,

$$g''(x) = [f'(x) + f''(x)]e^x + [f(x) + f'(x)]e^x = [f(x) + 2f'(x) + f''(x)]e^x$$

(b) Using the product rule and our answer from (a),

$$\begin{aligned} g'''(x) &= [f'(x) + 2f''(x) + f'''(x)]e^x + [f(x) + 2f'(x) + f''(x)]e^x \\ &= [f(x) + 3f'(x) + 3f''(x) + f'''(x)]e^x \end{aligned}$$

(c) We notice that the coefficients of the derivatives of f correspond to the entries in the rows of Pascal's Triangle.

$$\begin{array}{cccccc} & & & & & 1 \\ & & & & & & 1 \\ & & & & 1 & & 2 & & 1 \\ & & & 1 & & 3 & & 3 & & 1 \\ & & 1 & & 4 & & 6 & & 4 & & 1 \end{array}$$

Pascal's Triangle

- In the first derivative of g , the coefficients of f and f' correspond to the entries in the second row of Pascal's Triangle.
- In the second derivative of g , the coefficients of f , f' , and f'' correspond to the entries in the third row of Pascal's Triangle.
- In the third derivative of g , the coefficients of f , f' , f'' , and f''' correspond to the entries in the fourth row of Pascal's Triangle.
- We guess that, in the fourth derivative of g , the coefficients of f , f' , f'' , f''' , and $f^{(4)}$ will correspond to the entries in the fifth row of Pascal's Triangle.

That is, we guess

$$g^{(4)}(x) = [f(x) + 4f'(x) + 6f''(x) + 4f'''(x) + f^{(4)}(x)]e^x$$

This is verified by differentiating our answer from (a) using the product rule:

$$\begin{aligned}g'''(x) &= [f(x) + 3f'(x) + 3f''(x) + f'''(x)]e^x \\g^{(4)}(x) &= [f'(x) + 3f''(x) + 3f'''(x) + f^{(4)}(x)]e^x + [f(x) + 3f'(x) + 3f''(x) + f'''(x)]e^x \\&= [f(x) + 4f'(x) + 6f''(x) + 4f'''(x) + f^{(4)}(x)]e^x.\end{aligned}$$

S-21: (a) Using the chain rule for $f(x)$:

$$\begin{aligned}f'(x) &= (1 + 2x)e^{x+x^2} \\f''(x) &= (1 + 2x)(1 + 2x)e^{x+x^2} + (2)e^{x+x^2} = (4x^2 + 4x + 3)e^{x+x^2} \\h'(x) &= 1 + 3x \\h''(x) &= 3\end{aligned}$$

(b) $f(0) = h(0) = 1$; $f'(0) = h'(0) = 1$; $f''(0) = h''(0) = 3$

(c) f and h “start at the same place,” since $f(0) = h(0)$. If it were clear that $f'(x)$ were greater than $h'(x)$ for $x > 0$, then we would know that f grows faster than h , so we could conclude that $f(x) > h(x)$, as desired. Unfortunately, it is not obvious whether $(1 + 2x)e^{x+x^2}$ is always greater than $1 + 3x$ for positive x . So, we look to the second derivative. $f'(0) = h'(0)$, and $f''(x) = (4x^2 + 4x + 3)e^{x+x^2} > 3e^{x+x^2} > 3 = h''(x)$ when $x > 0$. Since $f'(0) = h'(0)$, and since f' grows faster than h' for positive x , we conclude $f'(x) > h'(x)$ for all positive x . Now we can conclude that (since $f(0) = h(0)$ and f grows faster than h when $x > 0$) also $f(x) > h(x)$ for all positive x .

Solutions to Exercises 4.1 — Jump to [TABLE OF CONTENTS](#)

S-22: In the quotient rule, there is a minus, not a plus. Also, $2(x + 1) + 2x$ is not the same as $2(x + 1)$.

The correct version is:

$$\begin{aligned}f(x) &= \frac{2x}{x+1} \\f'(x) &= \frac{2(x+1) - 2x}{(x+1)^2} \\&= \frac{2}{(x+1)^2}\end{aligned}$$

S-23: False: Lemma 4.1.14 tells us that, for a constant n , $\frac{d}{dx}\{x^n\} = nx^{n-1}$. Note that the base x is the variable and the exponent n is a constant. In the equation given in the question, the base 2 is a constant, and the exponent x is the variable: this is the opposite of the situation where Lemma 4.1.14 applies.

We do not yet know how to differentiate 2^x . We'll learn about it in Section 3.5.

S-24: Using the quotient rule,

$$f'(x) = \frac{2xe^x - 2e^x}{4x^2} = \frac{e^x(2x-2)}{4x^2} = \frac{(x-1)e^x}{2x^2}$$

S-25:

$$f'(x) = \frac{d}{dx}\{e^{2x}\} = \frac{d}{dx}\{(e^x)^2\} = 2\frac{d}{dx}\{e^x\}e^x = 2e^xe^x = 2(e^x)^2 = 2e^{2x}$$

S-26:

$$e^{a+x} = e^ae^x$$

Since e^a is just a constant,

$$\frac{d}{dx}\{e^ae^x\} = e^a\frac{d}{dx}\{e^x\} = e^ae^x = e^{a+x}$$

So, $f'(x) = f(x) = e^{a+x}$.

S-27: If the derivative is positive, the function is increasing, so let's start by finding the derivative. We use the product rule (although Question 12 gives a shortcut).

$$f'(x) = 1 \cdot e^x + xe^x = (1+x)e^x$$

Since e^x is always positive, $f'(x) > 0$ when $1+x > 0$. So, $f(x)$ is increasing when $x > -1$.

S-28: The question asks for $s''(1)$. We start our differentiation using the quotient rule:

$$\begin{aligned} s'(t) &= \frac{e^t(t^2+1) - e^t(2t)}{(t^2+1)^2} \\ &= \frac{e^t(t^2-2t+1)}{(t^2+1)^2} \end{aligned}$$

Using the quotient rule again,

$$\begin{aligned} s''(t) &= \frac{(t^2+1)^2 \frac{d}{dt}\{e^t(t^2-2t+1)\} - e^t(t^2-2t+1) \frac{d}{dt}\{(t^2+1)^2\}}{(t^2+1)^4} \\ &= \frac{(t^2+1)^2 \cdot [e^t(2t-2) + e^t(t^2-2t+1)] - e^t(t^2-2t+1) \cdot 2(t^2+1)(2t)}{(t^2+1)^4} \\ &= \frac{e^t(t^2+1)^2(t^2-1) - 4te^t(t-1)^2(t^2+1)}{(t^2+1)^4} \end{aligned}$$

$$s''(1) = 0$$

S-29: Using the product rule,

$$f'(x) = (e^x)(e^x - 1) + (e^x + 1)(e^x) = e^x(e^x - 1 + e^x + 1) = 2(e^x)^2 = 2e^{2x}$$

Alternate solution: using Question 25:

$$f(x) = e^{2x} - 1 \implies f'(x) = 2e^{2x}.$$

S-30: The question asks when $s'(t)$ is negative. So, we start by differentiating. Using the product rule:

$$\begin{aligned} s'(t) &= e^t(t^2 + 2t) \\ &= e^t \cdot t(t + 2) \end{aligned}$$

e^t is always positive, so $s'(t)$ is negative when t and $2 + t$ have opposite signs. This occurs when $-2 < t < 0$.

S-31: Every time we differentiate $f(x)$, the constant out front gets multiplied by an ever-decreasing constant, while the power decreases by one. As in Example 3.4.2, $\frac{d^{15}}{dx^{15}}ax^{15} = a \cdot 15!$. So, if $a \cdot 15! = 3$, then $a = \frac{3}{15!}$.

S-32: $f(x) = \frac{2}{3}x^6 + 5x^4 + 12x^2 + 9$ is a polynomial:

$$\begin{aligned} f'(x) &= 4x^5 + 20x^3 + 24x \\ &= 4x(x^4 + 5x^2 + 6) \\ &= 4x((x^2)^2 + 5(x^2) + 6) \\ &= 4x(x^2 + 2)(x^2 + 3) \end{aligned}$$

S-33: We can rewrite slightly to make every term into a power of t :

$$\begin{aligned} s(t) &= 3t^4 + 5t^3 - t^{-1} \\ s'(t) &= 4 \cdot 3t^3 + 3 \cdot 5t^2 - (-1) \cdot t^{-2} \\ &= 12t^3 + 15t^2 + \frac{1}{t^2} \end{aligned}$$

S-34: We could use the product rule here, but it's easier to simplify first. Don't be confused by the role reversal of x and y : x is the name of the function, and y is the variable.

$$\begin{aligned} x(y) &= \left(2y + \frac{1}{y}\right) \cdot y^3 \\ &= 2y^4 + y^2 \\ x'(y) &= 8y^3 + 2y \end{aligned}$$

S-35: We've already seen that $\frac{d}{dx}\{\sqrt{x}\} = \frac{1}{2\sqrt{x}}$, but if you forget this formula it is easy to figure out: $\sqrt{x} = x^{1/2}$, so $\frac{d}{dx}\{\sqrt{x}\} = \frac{1}{2}x^{-1/2} = \frac{1}{2\sqrt{x}}$.

Using the quotient rule:

$$T(x) = \frac{\sqrt{x} + 1}{x^2 + 3}$$
$$T'(x) = \frac{(x^2 + 3)\left(\frac{1}{2\sqrt{x}}\right) - (\sqrt{x} + 1)(2x)}{(x^2 + 3)^2}$$

S-36: We use quotient rule:

$$\frac{(x^2 + 3) \cdot 7 - 2x \cdot (7x + 2)}{(x^2 + 3)^2} = \frac{21 - 4x - 7x^2}{(x^2 + 3)^2}$$

S-37: Instead of multiplying to get our usual form of this polynomial, we can use the product rule.

If $f_1(x) = 3x^3 + 4x^2 + x + 1$ and $f_2(x) = 2x + 5$, then

$f_1'(x) = 9x^2 + 8x + 1$ and $f_2'(x) = 2$. Then

$$\begin{aligned} f'(0) &= f_1'(0)f_2(0) + f_1(0)f_2'(0) \\ &= (1)(5) + (1)(2) = 7 \end{aligned}$$

S-38: Using the quotient rule,

$$f'(x) = \frac{(x^2 + 5x)(9x^2) - (3x^3 + 1)(2x + 5)}{(x^2 + 5x)^2} = \frac{3x^4 + 30x^3 - 2x - 5}{(x^2 + 5x)^2}$$

S-39: We use quotient rule:

$$\frac{(2-x)(6x) - (3x^2 + 5)(-1)}{(2-x)^2} = \frac{-3x^2 + 12x + 5}{(x-2)^2}$$

S-40: We use quotient rule:

$$\frac{(3x^2 + 5)(-2x) - (2 - x^2)(6x)}{(3x^2 + 5)^2} = \frac{-22x}{(3x^2 + 5)^2}$$

S-41: We use quotient rule:

$$\frac{6x^2 \cdot (x+2) - (2x^3+1) \cdot 1}{(x+2)^2} = \frac{4x^3 + 12x^2 - 1}{(x+2)^2}$$

S-42: The derivative of the function is

$$\frac{(1-x^2) \cdot \frac{1}{2\sqrt{x}} - \sqrt{x} \cdot (-2x)}{(1-x^2)^2} = \frac{(1-x^2) - 2x \cdot (-2x)}{2\sqrt{x}(1-x^2)^2}$$

The derivative is undefined if either $x < 0$ or $x = 0, \pm 1$ (since the square-root is undefined for $x < 0$ and the denominator is zero when $x = 0, 1, -1$). Putting this together — the derivative exists for $x > 0, x \neq 1$.

S-43: Using the product rule seems faster than expanding.

$$\begin{aligned} f'(x) &= \frac{d}{dx} \{3\sqrt[5]{x} + 15\sqrt[3]{x} + 8\} (3x^2 + 8x - 5) + (3\sqrt[5]{x} + 15\sqrt[3]{x} + 8) \frac{d}{dx} \{3x^2 + 8x - 5\} \\ &= \frac{d}{dx} \left\{3x^{\frac{1}{5}} + 15x^{\frac{1}{3}} + 8\right\} (3x^2 + 8x - 5) + (3\sqrt[5]{x} + 15\sqrt[3]{x} + 8) \frac{d}{dx} \{3x^2 + 8x - 5\} \\ &= \left(\frac{3}{5}x^{-\frac{4}{5}} + 5x^{-\frac{2}{3}}\right) (3x^2 + 8x - 5) + (3\sqrt[5]{x} + 15\sqrt[3]{x} + 8) (6x + 8) \end{aligned}$$

S-44: To avoid the quotient rule, we can divide through the denominator:

$$\begin{aligned} f(x) &= \frac{(x^2 + 5x + 1)(\sqrt{x} + \sqrt[3]{x})}{x} = (x^2 + 5x + 1) \frac{(\sqrt{x} + \sqrt[3]{x})}{x} \\ &= (x^2 + 5x + 1)(x^{-1/2} + x^{-2/3}) \end{aligned}$$

Now, product rule:

$$f'(x) = (2x + 5)(x^{-1/2} + x^{-2/3}) + (x^2 + 5x + 1) \left(\frac{-1}{2}x^{-3/2} - \frac{2}{3}x^{-5/3}\right)$$

(If you simplified differently, or used the quotient rule, you probably came up with a different-looking answer. There is only one derivative, though, so all correct answers will look the same after sufficient algebraic manipulation.)

S-45: We differentiate using the power rule.

$$\begin{aligned} \frac{df}{dx} &= 3ax^2 + 2bx + c \\ \frac{d^2f}{dx^2} &= 6ax + 2b \\ \frac{d^3f}{dx^3} &= 6a \\ \frac{d^4f}{dx^4} &= 0 \end{aligned}$$

In the above work, remember that a , b , c , and d are all constants. Since they are nonzero constants, $\frac{d^3 f}{dx^3} = 6a \neq 0$. So, the fourth derivative is the first derivative to be identically zero: $n = 4$.

S-46: (a) In order to make $f(x)$ a little more tractable, let's change the format. Since

$$|x| = \begin{cases} x & x \geq 0 \\ -x & x < 0 \end{cases}, \text{ then:}$$

$$f(x) = \begin{cases} -x^2 & x < 0 \\ x^2 & x \geq 0. \end{cases}$$

Now, we turn to the definition of the derivative to figure out whether $f'(0)$ exists.

$$f'(0) = \lim_{h \rightarrow 0} \frac{f(0+h) - f(0)}{h} = \lim_{h \rightarrow 0} \frac{f(h) - 0}{h} = \lim_{h \rightarrow 0} \frac{f(h)}{h} \quad \text{if it exists.}$$

Since f looks different to the left and right of 0, in order to evaluate this limit, we look at the corresponding one-sided limits. Note that when h approaches 0 from the right, $h > 0$ so $f(h) = h^2$. By contrast, when h approaches 0 from the left, $h < 0$ so $f(h) = -h^2$.

$$\lim_{h \rightarrow 0^+} \frac{f(h)}{h} = \lim_{h \rightarrow 0^+} \frac{h^2}{h} = \lim_{h \rightarrow 0^+} h = 0$$

$$\lim_{h \rightarrow 0^-} \frac{f(h)}{h} = \lim_{h \rightarrow 0^-} \frac{-h^2}{h} = \lim_{h \rightarrow 0^-} -h = 0$$

Since both one-sided limits exist and are equal to 0,

$$\lim_{h \rightarrow 0} \frac{f(0+h) - f(0)}{h} = 0$$

and so f is differentiable at $x = 0$ and $f'(0) = 0$.

(b) From (a), $f'(0) = 0$ and

$$f(x) = \begin{cases} -x^2 & x < 0 \\ x^2 & x \geq 0. \end{cases}$$

So,

$$f'(x) = \begin{cases} -2x & x < 0 \\ 2x & x \geq 0. \end{cases}$$

Then, we know the second derivative of f everywhere except at $x = 0$:

$$f''(x) = \begin{cases} -2 & x < 0 \\ ? & x = 0 \\ 2 & x > 0. \end{cases}$$

So, whenever $x \neq 0$, $f''(x)$ exists. To investigate the differentiability of $f'(x)$ when $x = 0$, again we turn to the definition of a derivative. If

$$\lim_{h \rightarrow 0} \frac{f'(0+h) - f'(0)}{h}$$

exists, then $f''(0)$ exists.

$$\lim_{h \rightarrow 0} \frac{f'(0+h) - f'(0)}{h} = \lim_{h \rightarrow 0} \frac{f'(h) - 0}{h} = \lim_{h \rightarrow 0} \frac{f'(h)}{h}$$

Since $f(h)$ behaves differently when h is greater than or less than zero, we look at the one-sided limits.

$$\begin{aligned}\lim_{h \rightarrow 0^+} \frac{f'(h)}{h} &= \lim_{h \rightarrow 0^+} \frac{2h}{h} = 2 \\ \lim_{h \rightarrow 0^-} \frac{f'(h)}{h} &= \lim_{h \rightarrow 0^-} \frac{-2h}{h} = -2\end{aligned}$$

Since the one-sided limits do not agree,

$$\lim_{h \rightarrow 0} \frac{f'(0+h) - f'(0)}{h} = DNE$$

So, $f''(0)$ does not exist. Now we have a complete picture of $f''(x)$:

$$f''(x) = \begin{cases} -2 & x < 0 \\ DNE & x = 0 \\ 2 & x > 0. \end{cases}$$

S-47: Denote by m the slope of the common tangent, by (x_1, y_1) the point of tangency with $y = x^2$, and by (x_2, y_2) the point of tangency with $y = x^2 - 2x + 2$. Then we must have

$$y_1 = x_1^2 \quad y_2 = x_2^2 - 2x_2 + 2 \quad m = 2x_1 = 2x_2 - 2 = \frac{y_2 - y_1}{x_2 - x_1}$$

From the “ m ” equations we get $x_1 = \frac{m}{2}$, $x_2 = \frac{m}{2} + 1$ and

$$\begin{aligned}m &= \frac{y_2 - y_1}{x_2 - x_1} \\ &= y_2 - y_1 \\ &= x_2^2 - 2x_2 + 2 - x_1^2 \\ &= (x_2 - x_1)(x_2 + x_1) - 2(x_2 - 1) \\ &= \left(\frac{m}{2} + 1 - \frac{m}{2}\right) \left(\frac{m}{2} + 1 + \frac{m}{2}\right) - 2\left(\frac{m}{2} + 1 - 1\right) \\ &= (1)(m + 1) - 2\frac{m}{2} \\ &= 1\end{aligned}$$

$$\text{So, } m = 1, \quad x_1 = \frac{1}{2}, \quad y_1 = \frac{1}{4}, \quad x_2 = \frac{3}{2}, \quad y_2 = \frac{9}{4} - 3 + 2 = \frac{5}{4}$$

An equation of the common tangent is $y = x - \frac{1}{4}$.

S-48: The line $y = mx + b$ is tangent to $y = x^2$ at $x = \alpha$ if

$$2\alpha = m \text{ and } \alpha^2 = m\alpha + b \iff m = 2\alpha \text{ and } b = -\alpha^2$$

The same line $y = mx + b$ is tangent to $y = -x^2 + 2x - 5$ at $x = \beta$ if

$$\begin{aligned} -2\beta + 2 &= m \text{ and } -\beta^2 + 2\beta - 5 = m\beta + b \\ \iff m &= 2 - 2\beta \text{ and } b = -\beta^2 + 2\beta - 5 - (2 - 2\beta)\beta = \beta^2 - 5 \end{aligned}$$

For the line to be simultaneously tangent to the two parabolas we need

$$m = 2\alpha = 2 - 2\beta \text{ and } b = -\alpha^2 = \beta^2 - 5$$

Substituting $\alpha = 1 - \beta$ into $-\alpha^2 = \beta^2 - 5$ gives $-(1 - \beta)^2 = \beta^2 - 5$ or $2\beta^2 - 2\beta - 4 = 0$ or $\beta = -1, 2$. The corresponding values of the other parameters are $\alpha = 2, -1, m = 4, -2$ and $b = -4, -1$. The two lines are $y = 4x - 4$ and $y = -2x - 1$.

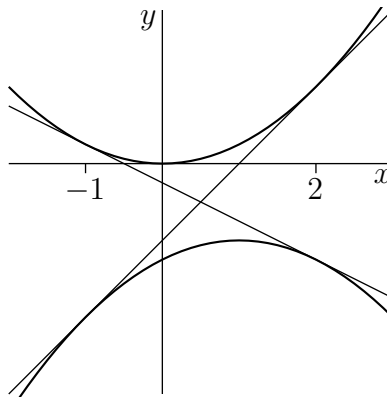

S-49: This limit represents the derivative computed at $x = 2$ of the function $f(x) = x^{2015}$. To see this, simply use the definition of the derivative at $a = 2$ with $f(x) = x^{2015}$:

$$\begin{aligned} \left. \frac{d}{dx} \{f(x)\} \right|_a &= \lim_{x \rightarrow a} \frac{f(x) - f(a)}{x - a} \\ \left. \frac{d}{dx} \{x^{2015}\} \right|_2 &= \lim_{x \rightarrow 2} \frac{x^{2015} - 2^{2015}}{x - 2} \end{aligned}$$

Since the derivative of $f(x)$ is $2015 \cdot x^{2014}$, then its value at $x = 2$ is exactly $2015 \cdot 2^{2014}$.

Solutions to Exercises 4.2 — Jump to [TABLE OF CONTENTS](#)

S-1:

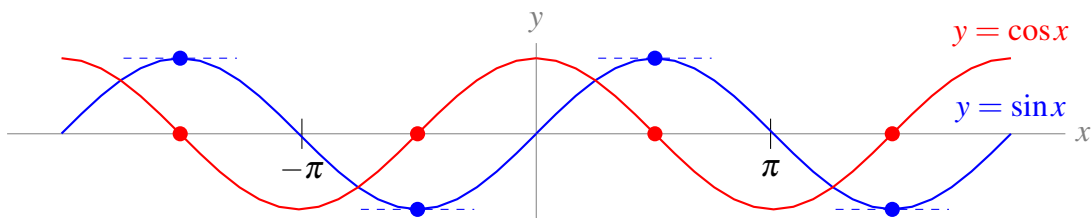

The graph $f(x) = \sin x$ has horizontal tangent lines precisely at those points where $\cos x = 0$. This must be true, since $\frac{d}{dx}\{\sin x\} = \cos x$: where the derivative of sine is zero, cosine itself is zero.

S-2:

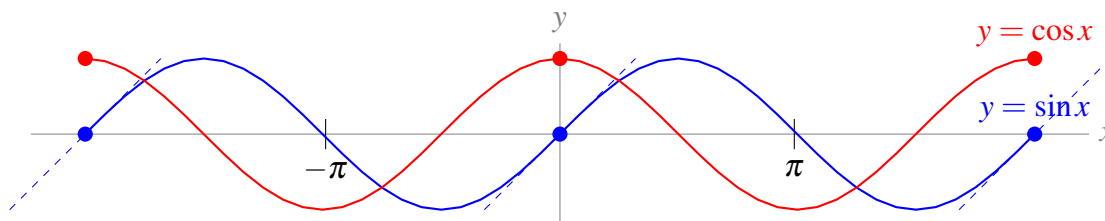

The graph $f(x) = \sin x$ has maximum slope at those points where $\cos x$ has a maximum. This makes sense, because $f'(x) = \cos x$: the maximum values of the slope of sine correspond to the maximum values of cosine.

S-3: The velocity of the particle is given by $h'(t) = \sin t$. Note $0 < 1 < \pi$, so $h'(1) > 0$ —the particle is rising (moving in the positive direction, in this case “up”). The acceleration of the particle is $h''(t) = \cos t$. Since $0 < 1 < \frac{\pi}{2}$, $h''(t) > 0$, so $h'(t)$ is increasing: the particle is moving up, and it’s doing so at an increasing rate. So, the particle is speeding up.

S-4: For this problem, remember that velocity has a sign indicating direction, while speed does not.

The velocity of the particle is given by $h'(t) = 3t^2 - 2t - 5$. At $t = 1$, the velocity of the particle is -4 , so the particle is moving downwards with a speed of 4 units per second. The acceleration of the particle is $h''(t) = 6t - 2$, so when $t = 1$, the acceleration is (positive) 4 units per second per second. That means the velocity (currently -4 units per second) is becoming a bigger number—since the velocity is negative, a bigger number is closer to zero, so the speed of the particle is getting smaller. (For instance, a velocity of -3 represents a slower motion than a velocity of -4 .) So, the particle is slowing down at $t = 1$.

S-5: For (a) and (b), notice the following:

$$\begin{aligned}\frac{d}{dx} \sin x &= \cos x \\ \frac{d}{dx} \cos x &= -\sin x \\ \frac{d}{dx} \{-\sin x\} &= -\cos x \\ \frac{d}{dx} \{-\cos x\} &= \sin x \\ \frac{d}{dx} \sin x &= \cos x\end{aligned}$$

The fourth derivative of $\sin x$ is $\sin x$, and the fourth derivative of $\cos x$ is $\cos x$, so (a) and (b) are true.

$$\begin{aligned}\frac{d}{dx} \tan x &= \sec^2 x \\ \frac{d}{dx} \sec^2 x &= 2 \sec x (\sec x \tan x) = 2 \sec^2 x \tan x \\ \frac{d}{dx} \{2 \sec^2 x \tan x\} &= (4 \sec x \cdot \sec x \tan x) \tan x + 2 \sec^2 x \sec^2 x \\ &= 4 \sec^2 x \tan^2 x + 2 \sec^4 x \\ \frac{d}{dx} \{4 \sec^2 x \tan^2 x + 2 \sec^4 x\} &= (8 \sec x \cdot \sec x \tan x) \tan^2 x + 4 \sec^2 x (2 \tan x \cdot \sec^2 x) \\ &\quad + 8 \sec^3 x \cdot \sec x \tan x \\ &= 8 \sec^2 x \tan^3 x + 16 \sec^4 x \tan x\end{aligned}$$

So, $\frac{d^4}{dx^4} \tan x = 8 \sec^2 x \tan^3 x + 16 \sec^4 x \tan x$. It certainly seems like this is not the same as $\tan x$, but remember that sometimes trig identities can fool you: $\tan^2 x + 1 = \sec^2 x$, and so on. So, to be absolutely sure that these are not equal, we need to find a value of x so that the output of one is not the same as the output of the other. When $x = \frac{\pi}{4}$:

$$8 \sec^2 x \tan^3 x + 16 \sec^4 x \tan x = 8 (\sqrt{2})^2 (1)^3 + 16 (\sqrt{2})^4 (1) = 80 \neq 1 = \tan x.$$

So, (c) is false.

S-6: You should memorize the derivatives of sine, cosine, and tangent.

$$f'(x) = \cos x - \sin x + \sec^2 x$$

S-7: $f'(x) = \cos x - \sin x$, so $f'(x) = 0$ precisely when $\sin x = \cos x$. This happens at $\pi/4$, but it also happens at $5\pi/4$. By looking at the unit circle, it is clear that $\sin x = \cos x$ whenever $x = \frac{\pi}{4} + \pi n$ for some integer n .

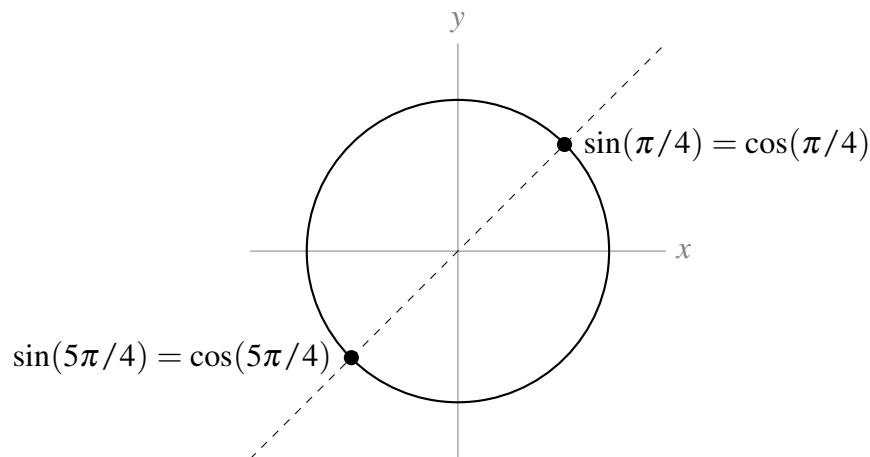

S-8:

- Solution 1: $f(x) = \sin^2 x + \cos^2 x = 1$, so $f'(x) = \frac{d}{dx} \{1\} = 0$.

- Solution 2: Using the formula for the derivative of a squared function,

$$f'(x) = 2 \sin x \cos x + 2 \cos x (-\sin x) = 2 \sin x \cos x - 2 \sin x \cos x = 0.$$

S-9: It is true that $2 \sin x \cos x = \sin(2x)$, but we don't know the derivative of $\sin(2x)$. So, we use the product rule:

$$f'(x) = 2 \cos x \cos x + 2 \sin x (-\sin x) = 2(\cos^2 x - \sin^2 x).$$

S-10:

- Solution 1: using the product rule,

$$f'(x) = e^x \cot x + e^x (-\csc^2 x) = e^x (\cot x - \csc^2 x).$$

- Solution 2: using the formula from Question 12, Section 3.5,

$$f'(x) = e^x (\cot x - \csc^2 x).$$

S-11: We use the quotient rule.

$$\begin{aligned} f'(x) &= \frac{(\cos x + \tan x)(2 \cos x + 3 \sec^2 x) - (2 \sin x + 3 \tan x)(-\sin x + \sec^2 x)}{(\cos x + \tan x)^2} \\ &= \frac{2 \cos^2 x + 3 \cos x \sec^2 x + 2 \cos x \tan x + 3 \tan x \sec^2 x}{(\cos x + \tan x)^2} \\ &\quad + \frac{2 \sin^2 x - 2 \sin x \sec^2 x + 3 \sin x \tan x - 3 \tan x \sec^2 x}{(\cos x + \tan x)^2} \\ &= \frac{2 + 3 \sec x + 2 \sin x - 2 \tan x \sec x + 3 \sin x \tan x}{(\cos x + \tan x)^2} \end{aligned}$$

S-12: We use the quotient rule.

$$\begin{aligned} f'(x) &= \frac{e^x(5 \sec x \tan x) - (5 \sec x + 1)e^x}{(e^x)^2} \\ &= \frac{5 \sec x \tan x - 5 \sec x - 1}{e^x} \end{aligned}$$

S-13: We use the product rule:

$$f'(x) = (e^x + \cot x)(30x^5 + \csc x \cot x) + (e^x - \csc^2 x)(5x^6 - \csc x)$$

S-14: We don't know how to differentiate this function as it is written, but an identity helps us. Since $\sin\left(\frac{\pi}{2} - \theta\right) = \cos \theta$, we see $f'(\theta) = \frac{d}{d\theta}\{\cos \theta\} = -\sin(\theta)$.

S-15: We know the derivative of $\sin x$, but not of $\sin(-x)$. So we re-write $f(x)$ using identities:

$$\begin{aligned}f(x) &= \sin(-x) + \cos(-x) \\ &= -\sin x + \cos x \\ f'(x) &= -\cos x - \sin x\end{aligned}$$

S-16: We apply the quotient rule.

$$\begin{aligned}s'(\theta) &= \frac{(\cos \theta - \sin \theta)(-\sin \theta + \cos \theta) - (\cos \theta + \sin \theta)(-\sin \theta - \cos \theta)}{(\cos \theta - \sin \theta)^2} \\ &= \frac{(\cos \theta - \sin \theta)^2 + (\cos \theta + \sin \theta)^2}{(\cos \theta - \sin \theta)^2} \\ &= 1 + \left(\frac{\cos \theta + \sin \theta}{\cos \theta - \sin \theta}\right)^2\end{aligned}$$

S-17: In order for f to be differentiable at $x = 0$, it must also be continuous at $x = 0$. This forces

$$\lim_{x \rightarrow 0^-} f(x) = \lim_{x \rightarrow 0^+} f(x) = f(0) \quad \text{or} \quad \lim_{x \rightarrow 0^-} \cos(x) = \lim_{x \rightarrow 0^+} (ax + b) = 1$$

or $b = 1$. In order for f to be differentiable at $x = 0$, we need the limit

$$\lim_{h \rightarrow 0} \frac{f(0+h) - f(0)}{h}$$

to exist. This is the case if and only if the two one-sided limits

$$\lim_{h \rightarrow 0^-} \frac{f(0+h) - f(0)}{h} = \lim_{h \rightarrow 0^-} \frac{\cos(h) - \cos(0)}{h}$$

and

$$\lim_{h \rightarrow 0^+} \frac{f(0+h) - f(0)}{h} = \lim_{h \rightarrow 0^+} \frac{(ah + b) - \cos(0)}{h} = a \quad \text{since } b = 1$$

exist and are equal. Because $\cos(x)$ is differentiable at $x = 0$ we have

$$\lim_{h \rightarrow 0^-} \frac{\cos(h) - \cos(0)}{h} = \left. \frac{d}{dx} \cos(x) \right|_{x=0} = -\sin(x) \Big|_{x=0} = 0$$

So, we need $a = 0$ and $b = 1$.

S-18: We compute the derivative of $\cos(x) + 2x$ as being $-\sin(x) + 2$, which evaluated at $x = \frac{\pi}{2}$ yields $-1 + 2 = 1$. Since we also compute $\cos(\pi/2) + 2(\pi/2) = 0 + \pi$, then the equation of the tangent line is

$$y - \pi = 1 \cdot (x - \pi/2).$$

S-19: This limit represents the derivative computed at $x = 2015$ of the function $f(x) = \cos(x)$. To see this, simply use the definition of the derivative at $a = 2015$ with $f(x) = \cos x$:

$$\begin{aligned} \left. \frac{d}{dx} \{f(x)\} \right|_a &= \lim_{x \rightarrow a} \frac{f(x) - f(a)}{x - a} \\ \left. \frac{d}{dx} \{\cos x\} \right|_{2015} &= \lim_{x \rightarrow 2015} \frac{\cos(x) - \cos(2015)}{x - 2015} \end{aligned}$$

Since the derivative of $f(x)$ is $-\sin(x)$, its value at $x = 2015$ is exactly $-\sin(2015)$.

S-20: This limit represents the derivative computed at $x = \pi/3$ of the function $f(x) = \cos x$. To see this, simply use the definition of the derivative at $a = \pi/3$ with $f(x) = \cos x$:

$$\begin{aligned} \left. \frac{d}{dx} \{f(x)\} \right|_a &= \lim_{x \rightarrow a} \frac{f(x) - f(a)}{x - a} \\ \left. \frac{d}{dx} \{\cos x\} \right|_{\pi/3} &= \lim_{x \rightarrow \pi/3} \frac{\cos(x) - \cos(\pi/3)}{x - \pi/3} \\ &= \lim_{x \rightarrow \pi/3} \frac{\cos(x) - 1/2}{x - \pi/3} \end{aligned}$$

Since the derivative of $f(x)$ is $-\sin x$, then its value at $x = \pi/3$ is exactly $-\sin(\pi/3) = -\sqrt{3}/2$.

S-21: This limit represents the derivative computed at $x = \pi$ of the function $f(x) = \sin(x)$. To see this, simply use the definition of the derivative at $a = \pi$ with $f(x) = \sin x$:

$$\begin{aligned} \left. \frac{d}{dx} \{f(x)\} \right|_a &= \lim_{x \rightarrow a} \frac{f(x) - f(a)}{x - a} \\ \left. \frac{d}{dx} \{\sin x\} \right|_{\pi} &= \lim_{x \rightarrow \pi} \frac{\sin(x) - \sin(\pi)}{x - \pi} \\ &= \lim_{x \rightarrow \pi} \frac{\sin(x)}{x - \pi} \end{aligned}$$

Since the derivative of $f(x)$ is $\cos(x)$, then its value at $x = \pi$ is exactly $\cos(\pi) = -1$.

S-22:

$$\tan \theta = \frac{\sin \theta}{\cos \theta}$$

So, using the quotient rule,

$$\begin{aligned}\frac{d}{d\theta}\{\tan\theta\} &= \frac{\cos\theta\cos\theta - \sin\theta(-\sin\theta)}{\cos^2\theta} = \frac{\cos^2\theta + \sin^2\theta}{\cos^2\theta} \\ &= \left(\frac{1}{\cos\theta}\right)^2 = \sec^2\theta\end{aligned}$$

S-23: In order for the function $f(x)$ to be continuous at $x = 0$, the left half formula $ax + b$ and the right half formula $\frac{6\cos x}{2 + \sin x + \cos x}$ must match up at $x = 0$. This forces

$$a \times 0 + b = \frac{6\cos 0}{2 + \sin 0 + \cos 0} = \frac{6}{3} \implies \boxed{b = 2}$$

In order for the derivative $f'(x)$ to exist at $x = 0$, the limit $\lim_{h \rightarrow 0} \frac{f(h) - f(0)}{h}$ must exist. In particular, the limits $\lim_{h \rightarrow 0^-} \frac{f(h) - f(0)}{h}$ and $\lim_{h \rightarrow 0^+} \frac{f(h) - f(0)}{h}$ must exist and be equal to each other.

When $h \rightarrow 0^-$, this means $h < 0$, so $f(h) = ah + b = ah + 2$. So:

$$\lim_{h \rightarrow 0^-} \frac{f(h) - f(0)}{h} = \lim_{h \rightarrow 0^-} \frac{(ah + 2) - 2}{h} = \frac{d}{dx}\{ax + 2\}\Big|_{x=0} = a.$$

Similarly, when $h \rightarrow 0^+$, then $h > 0$, so $f(h) = \frac{6\cosh}{1 + \sin h + \cos h}$ and

$$\begin{aligned}\lim_{h \rightarrow 0^+} \frac{f(h) - f(0)}{h} &= \frac{d}{dx} \left\{ \frac{6\cos x}{2 + \sin x + \cos x} \right\} \Big|_{x=0} \\ &= \frac{-6\sin x(2 + \sin x + \cos x) - 6\cos x(\cos x - \sin x)}{(2 + \sin x + \cos x)^2} \Big|_{x=0}.\end{aligned}$$

Since the limits from the left and right must be equal, this forces

$$a = \frac{-6\sin 0(2 + \sin 0 + \cos 0) - 6\cos 0(\cos 0 - \sin 0)}{(2 + \sin 0 + \cos 0)^2} = \frac{-6}{(2 + 1)^2} \implies \boxed{a = -\frac{2}{3}}$$

S-24: In order for $f'(x)$ to exist, $f(x)$ has to exist. We already know that $\tan x$ does not exist whenever $x = \frac{\pi}{2} + n\pi$ for any integer n . If we look a little deeper, since $\tan x = \frac{\sin x}{\cos x}$, the points where tangent does not exist correspond exactly to the points where cosine is zero.

From its graph, tangent looks like a smooth curve over its domain, so we might guess that everywhere tangent is defined, its derivative is defined. We can check this: $f'(x) = \sec^2 x = \left(\frac{1}{\cos x}\right)^2$. Indeed, wherever $\cos x$ is nonzero, f' exists.

So, $f'(x)$ exists for all values of x *except* when $x = \frac{\pi}{2} + n\pi$ for some integer n .

S-25: The function is differentiable whenever $x^2 + x - 6 \neq 0$ since the derivative equals

$$\frac{10\cos(x) \cdot (x^2 + x - 6) - 10\sin(x) \cdot (2x + 1)}{(x^2 + x - 6)^2},$$

which is well-defined unless $x^2 + x - 6 = 0$. We solve $x^2 + x - 6 = (x - 2)(x + 3) = 0$, and get $x = 2$ and $x = -3$. So, the function is differentiable for all real values x except for $x = 2$ and for $x = -3$.

S-26: The function is differentiable whenever $\sin(x) \neq 0$ since the derivative equals

$$\frac{\sin(x) \cdot (2x + 6) - \cos(x) \cdot (x^2 + 6x + 5)}{(\sin x)^2},$$

which is well-defined unless $\sin x = 0$. This happens when x is an integer multiple of π . So, the function is differentiable for all real values x except $x = n\pi$, where n is any integer.

S-27: We compute the derivative of $\tan(x)$ as being $\sec^2(x)$, which evaluated at $x = \frac{\pi}{4}$ yields 2. Since we also compute $\tan(\pi/4) = 1$, then the equation of the tangent line is

$$y - 1 = 2 \cdot (x - \pi/4).$$

S-28: We compute the derivative $y' = \cos(x) - \sin(x) + e^x$, which evaluated at $x = 0$ yields $1 - 0 + 1 = 2$. Since we also compute $y(0) = 0 + 1 + 1 = 2$, the equation of the tangent line is

$$y - 2 = 2(x - 0)$$

ie $y = 2x + 2$.

S-29: We are asked to solve $f'(x) = 0$. That is, $e^x[\sin x + \cos x] = 0$. Since e^x is always positive, that means we need to find all points where $\sin x + \cos x = 0$. That is, we need to find all values of x where $\sin x = -\cos x$. Looking at the unit circle, we see this happens whenever $x = \frac{3\pi}{4} + n\pi$ for any integer n .

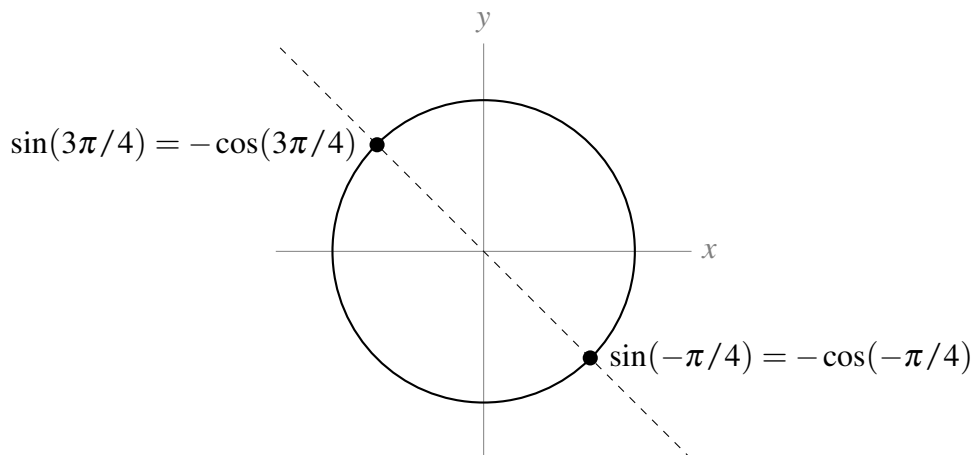

S-31: As usual, when dealing with the absolute value function, we can make things a little clearer by splitting it up into two pieces.

$$|x| = \begin{cases} x & x \geq 0 \\ -x & x < 0 \end{cases}$$

So,

$$\sin|x| = \begin{cases} \sin x & x \geq 0 \\ \sin(-x) & x < 0 \end{cases} = \begin{cases} \sin x & x \geq 0 \\ -\sin x & x < 0 \end{cases}$$

where we used the identity $\sin(-x) = -\sin x$. From here, it's easy to see $h'(x)$ when x is anything *other than zero*.

$$\frac{d}{dx}\{\sin|x|\} = \begin{cases} \cos x & x > 0 \\ ? & x = 0 \\ -\cos x & x < 0 \end{cases}$$

To decide whether $h(x)$ is differentiable at $x = 0$, we use the definition of the derivative. One word of explanation: usually in the definition of the derivative, h is the tiny “change in x ” that is going to zero. Since h is the name of our function, we need another letter to stand for the tiny change in x , the size of which is tending to zero. We chose t .

$$\lim_{t \rightarrow 0} \frac{h(t+0) - h(0)}{t} = \lim_{t \rightarrow 0} \frac{\sin|t|}{t}$$

We consider the behaviour of this function to the left and right of $t = 0$:

$$\frac{\sin|t|}{t} = \begin{cases} \frac{\sin t}{t} & t \geq 0 \\ \frac{\sin(-t)}{t} & t < 0 \end{cases} = \begin{cases} \frac{\sin t}{t} & t \geq 0 \\ -\frac{\sin t}{t} & t < 0 \end{cases}$$

Since we're evaluating the limit as t goes to zero, we need the fact that $\lim_{t \rightarrow 0} \frac{\sin t}{t} = 1$. We saw this in Section 3.5, but also we know enough now to evaluate it another way. Using the definition of the derivative:

$$\lim_{t \rightarrow 0} \frac{\sin t}{t} = \lim_{t \rightarrow 0} \frac{\sin(t+0) - \sin(0)}{t} = \left. \frac{d}{dx}\{\sin x\} \right|_{t=0} = \cos 0 = 1$$

At any rate, since we know $\lim_{t \rightarrow 0} \frac{\sin t}{t} = 1$, then:

$$\lim_{t \rightarrow 0^+} \frac{h(t+0) - h(0)}{t} = \lim_{t \rightarrow 0^+} \frac{\sin t}{t} = 1 \quad \lim_{t \rightarrow 0^-} \frac{h(t+0) - h(0)}{t} = \lim_{t \rightarrow 0^-} \frac{-\sin t}{t} = -1$$

So, since the one-sided limits disagree,

$$\lim_{t \rightarrow 0} \frac{h(t+0) - h(0)}{t} = DNE$$

so $h(x)$ is not differentiable at $x = 0$. Therefore,

$$h'(x) = \begin{cases} \cos x & x > 0 \\ -\cos x & x < 0 \end{cases}$$

S-32: Statement **i** is false, since $f(0) = 0$. Statement **iv** cannot hold, since a function that is differentiable is also continuous.

Since $\lim_{x \rightarrow 0^+} \frac{\sin x}{x} = 1$ (we saw this in Section 4.2),

$$\begin{aligned} \lim_{x \rightarrow 0^+} f(x) &= \lim_{x \rightarrow 0^+} \frac{\sin x}{\sqrt{x}} \\ &= \lim_{x \rightarrow 0^+} \sqrt{x} \frac{\sin x}{x} \\ &= 0 \cdot 1 = 0 \end{aligned}$$

So f is continuous at $x = 0$, and so Statement **ii** does not hold. Now, let's consider $f'(x)$.

$$\begin{aligned} \lim_{x \rightarrow 0^+} \frac{f(x) - f(0)}{x} &= \lim_{x \rightarrow 0^+} \frac{\frac{\sin x}{\sqrt{x}} - 0}{x} \\ &= \lim_{x \rightarrow 0^+} \frac{1}{\sqrt{x}} \frac{\sin x}{x} = +\infty \end{aligned}$$

Therefore, using the definition of the derivative,

$$\begin{aligned} f'(0) &= \lim_{x \rightarrow 0} \frac{f(x) - f(0)}{x} \quad \text{if it exists, but} \\ \lim_{x \rightarrow 0} \frac{f(x) - f(0)}{x} &= DNE \end{aligned}$$

since one of the one-sided limits does not exist. So f is continuous but not differentiable at $x = 0$. The correct statement is **iii**.

S-33: Recall that $\lim_{x \rightarrow 0} \frac{\sin x}{x} = 1$. In order to take advantage of this knowledge, we divide the numerator and denominator by x^5 (because 5 is the power of sine in the denominator, and a denominator that goes to zero generally makes a limit harder).

$$\lim_{x \rightarrow 0} \frac{\sin x^{27} + 2x^5 e^{x^{99}}}{\sin^5 x} = \lim_{x \rightarrow 0} \frac{\frac{\sin x^{27}}{x^5} + 2e^{x^{99}}}{\left(\frac{\sin x}{x}\right)^5}$$

Now the denominator goes to 1, which is nice, but we need to take care of the fraction $\frac{\sin x^{27}}{x^5}$ in the numerator. This fraction isn't very familiar, but we know that, as x goes to zero, x^{27} also goes to

zero, so that $\frac{\sin x^{27}}{x^{27}}$ goes to 1. Consequently,

$$\lim_{x \rightarrow 0} \frac{\sin x^{27} + 2x^5 e^{x^{99}}}{\sin^5 x} = \lim_{x \rightarrow 0} \frac{x^{22} \frac{\sin x^{27}}{x^{27}} + 2e^{x^{99}}}{\left(\frac{\sin x}{x}\right)^5} = \frac{0 \times 1 + 2 \times e^0}{1^5} = 2$$

Solutions to Exercises 4.3 — Jump to [TABLE OF CONTENTS](#)

S-1: (a) More urchins means less kelp, and fewer urchins means more kelp. This means kelp and urchins are negatively correlated, so $\frac{dK}{dU} < 0$.

If you aren't sure why that is, we give a more detailed explanation here, using the definition of the derivative. When h is a positive number, $U + h$ is greater than U , so $K(U + h)$ is less than U , hence $K(U + h) - K(U) < 0$. Therefore:

$$\lim_{h \rightarrow 0^+} \frac{K(U + h) - K(U)}{h} = \frac{\text{negative}}{\text{positive}} < 0.$$

Similarly, when h is negative, $U + h$ is less than U , so $K(U + h) - K(U) > 0$, and

$$\lim_{h \rightarrow 0^-} \frac{K(U + h) - K(U)}{h} = \frac{\text{positive}}{\text{negative}} < 0.$$

Therefore:

$$\frac{dK}{dU} = \lim_{h \rightarrow 0} \frac{K(U + h) - K(U)}{h} < 0.$$

(b) More otters means fewer urchins, and fewer otters means more urchins. So, otters and urchins are negatively correlated: $\frac{dU}{dO} < 0$.

(c) Using the chain rule, $\frac{dK}{dO} = \frac{dK}{dU} \cdot \frac{dU}{dO}$. Parts (a) and (b) tell us both these derivatives are negative, so their product is positive: $\frac{dK}{dO} > 0$.

We can also see that $\frac{dK}{dO} > 0$ by thinking about the relationships as described. When the otter population increases, the urchin population decreases, so the kelp population increases. That means when the otter population increases, the kelp population also increases, so kelp and otters are positively correlated. The chain rule is a formal version of this kind of reasoning.

S-2:

$$\frac{dA}{dE} = \frac{dA}{dB} \cdot \frac{dB}{dC} \cdot \frac{dC}{dD} \cdot \frac{dD}{dE} < 0$$

since we multiply three positive quantities and one negative.

S-3: Applying the chain rule:

$$\begin{aligned}\frac{d}{dx}\{\cos(5x+3)\} &= -\sin(5x+3) \cdot \frac{d}{dx}\{5x+3\} \\ &= -\sin(5x+3) \cdot 5\end{aligned}$$

S-4: Using the chain rule,

$$\begin{aligned}f'(x) &= \frac{d}{dx}\{(x^2+2)^5\} \\ &= 5(x^2+2)^4 \cdot \frac{d}{dx}\{x^2+2\} \\ &= 5(x^2+2)^4 \cdot 2x \\ &= 10x(x^2+2)^4\end{aligned}$$

S-5: Using the chain rule,

$$\begin{aligned}T'(k) &= \frac{d}{dk}\{(4k^4+2k^2+1)^{17}\} \\ &= 17(4k^4+2k^2+1)^{16} \cdot \frac{d}{dk}\{4k^4+2k^2+1\} \\ &= 17(4k^4+2k^2+1)^{16} \cdot (16k^3+4k)\end{aligned}$$

S-6: Using the chain rule:

$$\begin{aligned}\frac{d}{dx}\left\{\sqrt{\frac{x^2+1}{x^2-1}}\right\} &= \frac{1}{2\sqrt{\frac{x^2+1}{x^2-1}}} \cdot \frac{d}{dx}\left\{\frac{x^2+1}{x^2-1}\right\} \\ &= \frac{1}{2}\sqrt{\frac{x^2-1}{x^2+1}} \cdot \frac{d}{dx}\left\{\frac{x^2+1}{x^2-1}\right\}\end{aligned}$$

And now, the quotient rule:

$$\begin{aligned}&= \frac{1}{2}\sqrt{\frac{x^2-1}{x^2+1}} \cdot \left(\frac{(x^2-1)(2x) - (x^2+1)2x}{(x^2-1)^2}\right) \\ &= \frac{1}{2}\sqrt{\frac{x^2-1}{x^2+1}} \cdot \left(\frac{-4x}{(x^2-1)^2}\right) \\ &= \sqrt{\frac{x^2-1}{x^2+1}} \cdot \left(\frac{-2x}{(x^2-1)^2}\right) \\ &= \frac{-2x}{(x^2-1)\sqrt{x^4-1}}\end{aligned}$$

S-7: If we let $g(x) = e^x$ and $h(x) = \cos(x^2)$, then $f(x) = g(h(x))$, so $f'(x) = g'(h(x)) \cdot h'(x)$.

$$f'(x) = e^{\cos(x^2)} \cdot \frac{d}{dx} \{ \cos(x^2) \}$$

In order to evaluate $\frac{d}{dx} \{ \cos(x^2) \}$, we'll need the chain rule *again*.

$$\begin{aligned} &= e^{\cos(x^2)} \cdot [-\sin(x^2)] \cdot \frac{d}{dx} \{ x^2 \} \\ &= -e^{\cos(x^2)} \cdot \sin(x^2) \cdot 2x \end{aligned}$$

S-8: We use the chain rule, followed by the quotient rule:

$$\begin{aligned} f'(x) &= g' \left(\frac{x}{h(x)} \right) \cdot \frac{d}{dx} \left\{ \frac{x}{h(x)} \right\} \\ &= g' \left(\frac{x}{h(x)} \right) \cdot \frac{h(x) - xh'(x)}{h(x)^2} \end{aligned}$$

When $x = 2$:

$$\begin{aligned} f'(2) &= g' \left(\frac{2}{h(2)} \right) \frac{h(2) - 2h'(2)}{h(2)^2} \\ &= 4 \frac{2 - 2 \times 3}{2^2} = -4 \end{aligned}$$

S-9: Using the chain rule, followed by the product rule:

$$\begin{aligned} \frac{d}{dx} \{ e^{x \cos(x)} \} &= e^{x \cos(x)} \frac{d}{dx} \{ x \cos(x) \} \\ &= [\cos(x) - x \sin(x)] e^{x \cos(x)} \end{aligned}$$

S-10: Using the chain rule:

$$\begin{aligned} \frac{d}{dx} \{ e^{x^2 + \cos(x)} \} &= e^{x^2 + \cos(x)} \frac{d}{dx} \{ x^2 + \cos(x) \} \\ &= [2x - \sin(x)] e^{x^2 + \cos(x)} \end{aligned}$$

S-11: Using the chain rule, followed by the quotient rule:

$$\begin{aligned}\frac{d}{dx} \left\{ \sqrt{\frac{x-1}{x+2}} \right\} &= \frac{1}{2\sqrt{\frac{x-1}{x+2}}} \frac{d}{dx} \left\{ \frac{x-1}{x+2} \right\} \\ &= \frac{\sqrt{x+2}}{2\sqrt{x-1}} \cdot \frac{(x+2) - (x-1)}{(x+2)^2} \\ &= \frac{3}{2\sqrt{x-1}\sqrt{x+2}^3}\end{aligned}$$

S-12: First, we manipulate our function to make it easier to differentiate:

$$f(x) = x^{-2} + (x^2 - 1)^{1/2}$$

Now, we can use the power rule to differentiate $\frac{1}{x^2}$. This will be easier than differentiating $\frac{1}{x^2}$ using quotient rule, but if you prefer, quotient rule will also work.

$$\begin{aligned}f'(x) &= -2x^{-3} + \frac{1}{2}(x^2 - 1)^{-1/2} \cdot \frac{d}{dx}\{x^2 - 1\} \\ &= -2x^{-3} + \frac{1}{2}(x^2 - 1)^{-1/2}(2x) \\ &= \frac{-2}{x^3} + \frac{x}{\sqrt{x^2 - 1}}\end{aligned}$$

The function $f(x)$ is only defined when $x \neq 0$ and when $x^2 - 1 \geq 0$. That is, when x is in $(-\infty, -1] \cup [1, \infty)$. We have an added restriction on the domain of $f'(x)$: $x^2 - 1$ must not be zero. So, the domain of $f'(x)$ is $(-\infty, -1) \cup (1, \infty)$.

S-13: We use the quotient rule, noting that $\frac{d}{dx}\{\sin 5x\} = 5 \cos 5x$:

$$f'(x) = \frac{(1+x^2)(5 \cos 5x) - (\sin 5x)(2x)}{(1+x^2)^2}$$

S-14: If we let $g(x) = \sec x$ and $h(x) = e^{2x+7}$, then $f(x) = g(h(x))$, so by the chain rule, $f'(x) = g'(h(x)) \cdot h'(x)$. Since $g'(x) = \sec x \tan x$:

$$\begin{aligned}f'(x) &= g'(h(x)) \cdot h'(x) \\ &= \sec(h(x)) \tan(h(x)) \cdot h'(x) \\ &= \sec(e^{2x+7}) \tan(e^{2x+7}) \cdot \frac{d}{dx}\{e^{2x+7}\}\end{aligned}$$

Here, we need the chain rule again:

$$\begin{aligned}&= \sec(e^{2x+7}) \tan(e^{2x+7}) \cdot \left[e^{2x+7} \cdot \frac{d}{dx}\{2x+7\} \right] \\ &= \sec(e^{2x+7}) \tan(e^{2x+7}) \cdot [e^{2x+7} \cdot 2] \\ &= 2e^{2x+7} \sec(e^{2x+7}) \tan(e^{2x+7})\end{aligned}$$

S-15: It is possible to start in on this problem with the product rule and then the chain rule, but it's easier if we simplify first. Since $\tan^2 x + 1 = \sec^2 x = \frac{1}{\cos^2 x}$, we see

$$f(x) = \frac{\cos^2 x}{\cos^2 x} = 1$$

for all values of x for which $\cos x$ is nonzero. That is, $f(x) = 1$ for every x that is not an integer multiple of $\pi/2$ (and $f(x)$ is not defined when x is an integer multiple of $\pi/2$). Therefore, $f'(x) = 0$ for every x on which f exists, and in particular $f'(\pi/4) = 0$. Also, $f(\pi/4) = 1$, so the tangent line to f at $x = \pi/4$ is the line with slope 0, passing through the point $(\pi/4, 1)$:

$$y = 1$$

S-16: Velocity is the derivative of position with respect to time. So, the velocity of the particle is given by $s'(t)$. We need to find $s'(t)$, and determine when it is zero.

To differentiate, we use the chain rule.

$$\begin{aligned} s'(t) &= e^{t^3-7t^2+8t} \cdot \frac{d}{dt}\{t^3 - 7t^2 + 8t\} \\ &= e^{t^3-7t^2+8t} \cdot (3t^2 - 14t + 8) \end{aligned}$$

To determine where this function is zero, we factor:

$$= e^{t^3-7t^2+8t} \cdot (3t - 2)(t - 4)$$

So, the velocity is zero when $e^{t^3-7t^2+8t} = 0$, when $3t - 2 = 0$, and when $t - 4 = 0$. Since $e^{t^3-7t^2+8t}$ is *never* zero, this tells us that the velocity is zero precisely when $t = \frac{2}{3}$ or $t = 4$.

S-17: The slope of the tangent line is the derivative. If we let $f(x) = \tan x$ and $g(x) = e^{x^2}$, then $f(g(x)) = \tan(e^{x^2})$, so $y' = f'(g(x)) \cdot g'(x)$:

$$y' = \sec^2(e^{x^2}) \cdot \frac{d}{dx}\{e^{x^2}\}$$

We find ourselves once more in need of the chain rule:

$$\begin{aligned} &= \sec^2(e^{x^2}) \cdot e^{x^2} \frac{d}{dx}\{x^2\} \\ &= \sec^2(e^{x^2}) \cdot e^{x^2} \cdot 2x \end{aligned}$$

Finally, we evaluate this derivative at the point $x = 1$:

$$\begin{aligned} y'(1) &= \sec^2(e) \cdot e \cdot 2 \\ &= 2e \sec^2 e \end{aligned}$$

S-18: Using the Product rule,

$$y' = \frac{d}{dx}\{e^{4x}\} \tan x + e^{4x} \sec^2 x$$

and the chain rule:

$$\begin{aligned} &= e^{4x} \cdot \frac{d}{dx}\{4x\} \cdot \tan x + e^{4x} \sec^2 x \\ &= 4e^{4x} \tan x + e^{4x} \sec^2 x \end{aligned}$$

S-19: Using the quotient rule,

$$f'(x) = \frac{(3x^2)(1 + e^{3x}) - (x^3) \cdot \frac{d}{dx}\{1 + e^{3x}\}}{(1 + e^{3x})^2}$$

Now, the chain rule:

$$= \frac{(3x^2)(1 + e^{3x}) - (x^3)(3e^{3x})}{(1 + e^{3x})^2}$$

So, when $x = 1$:

$$f'(1) = \frac{3(1 + e^3) - 3e^3}{(1 + e^3)^2} = \frac{3}{(1 + e^3)^2}$$

S-20: This requires us to apply the chain rule twice.

$$\begin{aligned} \frac{d}{dx}\{e^{\sin^2(x)}\} &= e^{\sin^2(x)} \cdot \frac{d}{dx}\{\sin^2(x)\} \\ &= e^{\sin^2(x)}(2 \sin(x)) \cdot \frac{d}{dx}\sin(x) \\ &= e^{\sin^2(x)}(2 \sin(x)) \cdot \cos(x) \end{aligned}$$

S-21: This requires us to apply the chain rule twice.

$$\begin{aligned} \frac{d}{dx}\{\sin(e^{5x})\} &= \cos(e^{5x}) \cdot \frac{d}{dx}\{e^{5x}\} \\ &= \cos(e^{5x})(e^{5x}) \cdot \frac{d}{dx}\{5x\} \\ &= \cos(e^{5x})(e^{5x}) \cdot 5 \end{aligned}$$

S-22: We'll use the chain rule twice.

$$\begin{aligned}\frac{d}{dx} \{e^{\cos(x^2)}\} &= e^{\cos(x^2)} \cdot \frac{d}{dx} \{\cos(x^2)\} \\ &= e^{\cos(x^2)} \cdot (-\sin(x^2)) \cdot \frac{d}{dx} \{x^2\} \\ &= -e^{\cos(x^2)} \cdot \sin(x^2) \cdot 2x\end{aligned}$$

S-23: We start with the chain rule:

$$\begin{aligned}y' &= -\sin(x^2 + \sqrt{x^2 + 1}) \cdot \frac{d}{dx} \{x^2 + \sqrt{x^2 + 1}\} \\ &= -\sin(x^2 + \sqrt{x^2 + 1}) \cdot \left(2x + \frac{d}{dx} \{\sqrt{x^2 + 1}\}\right)\end{aligned}$$

and find ourselves in need of chain rule a second time:

$$\begin{aligned}&= -\sin(x^2 + \sqrt{x^2 + 1}) \cdot \left(2x + \frac{1}{2\sqrt{x^2 + 1}} \cdot \frac{d}{dx} \{x^2 + 1\}\right) \\ &= -\sin(x^2 + \sqrt{x^2 + 1}) \cdot \left(2x + \frac{2x}{2\sqrt{x^2 + 1}}\right)\end{aligned}$$

S-24:

$$y = (1 + x^2) \cos^2 x$$

Using the product rule,

$$y' = (2x) \cos^2 x + (1 + x^2) \frac{d}{dx} \{\cos^2 x\}$$

Here, we'll need to use the chain rule. Remember $\cos^2 x = [\cos x]^2$.

$$\begin{aligned}&= 2x \cos^2 x + (1 + x^2) 2 \cos x \cdot \frac{d}{dx} \{\cos x\} \\ &= 2x \cos^2 x + (1 + x^2) 2 \cos x \cdot (-\sin x) \\ &= 2x \cos^2 x - 2(1 + x^2) \sin x \cos x\end{aligned}$$

S-25: We use the quotient rule, noting by the chain rule that $\frac{d}{dx} \{e^{3x}\} = 3e^{3x}$:

$$\begin{aligned}y' &= \frac{(1 + x^2) \cdot 3e^{3x} - e^{3x}(2x)}{(1 + x^2)^2} \\ &= \frac{e^{3x}(3x^2 - 2x + 3)}{(1 + x^2)^2}\end{aligned}$$

S-26: By the chain rule,

$$\frac{d}{dx} \{h(x^2)\} = h'(x^2) \cdot 2x$$

Using the product rules and the result above,

$$g'(x) = 3x^2h(x^2) + x^3h'(x^2)2x$$

Plugging in $x = 2$:

$$\begin{aligned} g'(2) &= 3(2^2)h(2^2) + 2^3h'(2^2)2 \times 2 \\ &= 12h(4) + 32h'(4) = 12 \times 2 - 32 \times 2 \\ &= -40 \end{aligned}$$

S-27: Let $f(x) = xe^{-(x^2-1)/2} = xe^{(1-x^2)/2}$. Then, using the product rule,

$$f'(x) = e^{(1-x^2)/2} + x \cdot \frac{d}{dx} \left\{ e^{(1-x^2)/2} \right\}$$

Here, we need the chain rule:

$$\begin{aligned} &= e^{(1-x^2)/2} + x \cdot e^{(1-x^2)/2} \frac{d}{dx} \left\{ \frac{1}{2}(1-x^2) \right\} \\ &= e^{(1-x^2)/2} + x \cdot e^{(1-x^2)/2} \cdot (-x) \\ &= (1-x^2)e^{(1-x^2)/2} \end{aligned}$$

There is no power of e that is equal to zero; so if the product above is zero, it must be that $1-x^2 = 0$. This happens for $x = \pm 1$. On the curve, when $x = 1$, $y = 1$, and when $x = -1$, $y = -1$. So the points are $(1, 1)$ and $(-1, -1)$.

S-28: The question asks when $s'(t)$ is negative. So, we start by differentiating. Using the chain rule:

$$\begin{aligned} s'(t) &= \cos\left(\frac{1}{t}\right) \cdot \frac{d}{dt} \left\{ \frac{1}{t} \right\} \\ &= \cos\left(\frac{1}{t}\right) \cdot \frac{-1}{t^2} \end{aligned}$$

When $t \geq 1$, $\frac{1}{t}$ is between 0 and 1. Since $\cos \theta$ is positive for $0 \leq \theta < \pi/2$, and $\pi/2 > 1$, we see that $\cos\left(\frac{1}{t}\right)$ is positive for the entire domain of $s(t)$. Also, $\frac{-1}{t^2}$ is negative for the entire domain of the function. We conclude that $s'(t)$ is negative for the entire domain of $s(t)$, so the particle is *always* moving in the negative direction.

S-29: We present two solutions: one where we dive right in and use the quotient rule, and another where we simplify first and use the product rule.

- Solution 1: We begin with the quotient rule:

$$\begin{aligned} f'(x) &= \frac{\cos^3(5x-7) \frac{d}{dx}\{e^x\} - e^x \frac{d}{dx}\{\cos^3(5x-7)\}}{\cos^6(5x-7)} \\ &= \frac{\cos^3(5x-7)e^x - e^x \frac{d}{dx}\{\cos^3(5x-7)\}}{\cos^6(5x-7)} \end{aligned}$$

Now, we use the chain rule. Since $\cos^3(5x-7) = [\cos(5x-7)]^3$, our “outside” function is $g(x) = x^3$, and our “inside” function is $h(x) = \cos(5x-7)$.

$$= \frac{\cos^3(5x-7)e^x - e^x \cdot 3\cos^2(5x-7) \cdot \frac{d}{dx}\{\cos(5x-7)\}}{\cos^6(5x-7)}$$

We need the chain rule again!

$$\begin{aligned} &= \frac{\cos^3(5x-7)e^x - e^x \cdot 3\cos^2(5x-7) \cdot [-\sin(5x-7) \cdot \frac{d}{dx}\{5x-7\}]}{\cos^6(5x-7)} \\ &= \frac{\cos^3(5x-7)e^x - e^x \cdot 3\cos^2(5x-7) \cdot [-\sin(5x-7) \cdot 5]}{\cos^6(5x-7)} \end{aligned}$$

We finish by simplifying:

$$\begin{aligned} &= \frac{e^x \cos^2(5x-7) (\cos(5x-7) + 15 \sin(5x-7))}{\cos^6(5x-7)} \\ &= e^x \frac{\cos(5x-7) + 15 \sin(5x-7)}{\cos^4(5x-7)} \\ &= e^x (\sec^3(5x-7) + 15 \tan(5x-7) \sec^3(5x-7)) \\ &= e^x \sec^3(5x-7) (1 + 15 \tan(5x-7)) \end{aligned}$$

- Solution 2: We simplify to avoid the quotient rule:

$$\begin{aligned} f(x) &= \frac{e^x}{\cos^3(5x-7)} \\ &= e^x \sec^3(5x-7) \end{aligned}$$

Now we use the product rule to differentiate:

$$f'(x) = e^x \sec^3(5x-7) + e^x \frac{d}{dx}\{\sec^3(5x-7)\}$$

Here, we'll need the chain rule. Since $\sec^3(5x-7) = [\sec(5x-7)]^3$, our “outside” function is $g(x) = x^3$ and our “inside” function is $h(x) = \sec(5x-7)$, so that $g(h(x)) = [\sec(5x-7)]^3 = \sec^3(5x-7)$.

$$= e^x \sec^3(5x-7) + e^x \cdot 3 \sec^2(5x-7) \cdot \frac{d}{dx}\{\sec(5x-7)\}$$

We need the chain rule again! Recall $\frac{d}{dx}\{\sec x\} = \sec x \tan x$.

$$\begin{aligned} &= e^x \sec^3(5x-7) + e^x \cdot 3 \sec^2(5x-7) \cdot \sec(5x-7) \tan(5x-7) \cdot \frac{d}{dx}\{5x-7\} \\ &= e^x \sec^3(5x-7) + e^x \cdot 3 \sec^2(5x-7) \cdot \sec(5x-7) \tan(5x-7) \cdot 5 \end{aligned}$$

We finish by simplifying:

$$= e^x \sec^3(5x-7)(1 + 15 \tan(5x-7))$$

S-30:

- Solution 1: In Example 4.1.11, we generalized the product rule to three factors:

$$\frac{d}{dx}\{f(x)g(x)h(x)\} = f'(x)g(x)h(x) + f(x)g'(x)h(x) + f(x)g(x)h'(x)$$

Using this rule:

$$\begin{aligned} \frac{d}{dx}\{(x)(e^{2x})(\cos 4x)\} &= \frac{d}{dx}\{x\} \cdot e^{2x} \cos 4x + x \cdot \frac{d}{dx}\{e^{2x}\} \cdot \cos 4x + xe^{2x} \cdot \frac{d}{dx}\{\cos 4x\} \\ &= e^{2x} \cos 4x + x(2e^{2x}) \cos 4x + xe^{2x}(-4 \sin 4x) \\ &= e^{2x} \cos 4x + 2xe^{2x} \cos 4x - 4xe^{2x} \sin 4x \end{aligned}$$

- Solution 2: We can use the product rule twice. In the first step, we split the function $xe^{2x} \cos 4x$ into the product of two functions.

$$\begin{aligned} \frac{d}{dx}\{(xe^{2x})(\cos 4x)\} &= \frac{d}{dx}\{xe^{2x}\} \cdot \cos 4x + xe^{2x} \cdot \frac{d}{dx}\{\cos 4x\} \\ &= \left(\frac{d}{dx}\{x\} \cdot e^{2x} + x \cdot \frac{d}{dx}\{e^{2x}\}\right) \cdot \cos 4x + xe^{2x} \cdot \frac{d}{dx}\{\cos 4x\} \\ &= (e^{2x} + x(2e^{2x})) \cdot \cos 4x + xe^{2x}(-4 \sin 4x) \\ &= e^{2x} \cos 4x + 2xe^{2x} \cos 4x - 4xe^{2x} \sin 4x \end{aligned}$$

S-31: At time t , the particle is at the point $(x(t), y(t))$, with $x(t) = \cos t$ and $y(t) = \sin t$. Over time, the particle traces out a curve; let's call that curve $y = f(x)$. Then $y(t) = f(x(t))$, so the slope of the curve at the point $(x(t), y(t))$ is $f'(x(t))$. You are to determine the values of t for which $f'(x(t)) = -1$.

By the chain rule

$$y'(t) = f'(x(t)) \cdot x'(t)$$

Substituting in $x(t) = \cos t$ and $y(t) = \sin t$ gives

$$\cos t = f'(x(t)) \cdot (-\sin t)$$

so that

$$f'(x(t)) = -\frac{\cos t}{\sin t}$$

is -1 precisely when $\sin t = \cos t$. This happens whenever $t = \frac{\pi}{4}$.

Remark: the path traced by the particle is a semicircle. You can think about the point on the unit circle with angle t , or you can notice that $x^2 + y^2 = \sin^2 t + \cos^2 t = 1$.

S-32: Let $f(x) = e^{x+x^2}$ and $g(x) = 1 + x$. Then $f(0) = g(0) = 1$.

$f'(x) = (1 + 2x)e^{x+x^2}$ and $g'(x) = 1$. When $x > 0$,

$$f'(x) = (1 + 2x)e^{x+x^2} > 1 \cdot e^{x+x^2} = e^{x+x^2} > e^{0+0^2} = 1 = g'(x).$$

Since $f(0) = g(0)$, and $f'(x) > g'(x)$ for all $x > 0$, that means f and g start at the same place, but f always grows faster. Therefore, $f(x) > g(x)$ for all $x > 0$.

S-33: Since $\sin 2x$ and $2 \sin x \cos x$ are the same function, they have the same derivative.

$$\begin{aligned}\sin 2x &= 2 \sin x \cos x \\ \Rightarrow \frac{d}{dx} \{\sin 2x\} &= \frac{d}{dx} \{2 \sin x \cos x\} \\ 2 \cos 2x &= 2[\cos^2 x - \sin^2 x] \\ \cos 2x &= \cos^2 x - \sin^2 x\end{aligned}$$

We conclude $\cos 2x = \cos^2 x - \sin^2 x$, which is another common trig identity.

Remark: if we differentiate both sides of this equation, we get the original identity back.

S-34:

$$\begin{aligned}f(x) &= \sqrt[3]{\frac{e^{\csc x^2}}{\sqrt{x^3 - 9 \tan x}}} \\ &= \left(\frac{e^{\csc x^2}}{\sqrt{x^3 - 9 \tan x}} \right)^{\frac{1}{3}}\end{aligned}$$

To begin the differentiation, we can choose our “outside” function to be $g(x) = x^{\frac{1}{3}}$, and our “inside”

function to be $h(x) = \frac{e^{\csc x^2}}{\sqrt{x^3 - 9 \tan x}}$. Then $f(x) = g(h(x))$, so

$$f'(x) = g'(h(x)) \cdot h'(x) = \frac{1}{3}(h(x))^{-\frac{2}{3}} h'(x):$$

$$\begin{aligned}f'(x) &= \frac{1}{3} \left(\frac{e^{\csc x^2}}{\sqrt{x^3 - 9 \tan x}} \right)^{-\frac{2}{3}} \cdot \frac{d}{dx} \left\{ \frac{e^{\csc x^2}}{\sqrt{x^3 - 9 \tan x}} \right\} \\ &= \frac{1}{3} \left(\frac{\sqrt{x^3 - 9 \tan x}}{e^{\csc x^2}} \right)^{\frac{2}{3}} \cdot \frac{d}{dx} \left\{ \frac{e^{\csc x^2}}{\sqrt{x^3 - 9 \tan x}} \right\}\end{aligned}$$

This leads us to use the quotient rule:

$$= \frac{1}{3} \left(\frac{\sqrt{x^3-9}\tan x}{e^{\csc x^2}} \right)^{\frac{2}{3}} \left(\frac{\sqrt{x^3-9}\tan x \frac{d}{dx} \{e^{\csc x^2}\} - e^{\csc x^2} \frac{d}{dx} \{\sqrt{x^3-9}\tan x\}}{(\tan^2 x)(x^3-9)} \right)$$

Let's figure out those two derivatives on their own, then plug them in. Using the chain rule twice:

$$\begin{aligned} \frac{d}{dx} \{e^{\csc x^2}\} &= e^{\csc x^2} \frac{d}{dx} \{\csc x^2\} = e^{\csc x^2} \cdot (-\csc(x^2) \cot(x^2)) \cdot \frac{d}{dx} \{x^2\} \\ &= -2xe^{\csc x^2} \csc(x^2) \cot(x^2) \end{aligned}$$

For the other derivative, we start with the product rule, then chain:

$$\begin{aligned} \frac{d}{dx} \{\sqrt{x^3-9}\tan x\} &= \frac{d}{dx} \{\sqrt{x^3-9}\} \cdot \tan x + \sqrt{x^3-9} \sec^2 x \\ &= \frac{1}{2\sqrt{x^3-9}} \frac{d}{dx} \{x^3-9\} \cdot \tan x + \sqrt{x^3-9} \sec^2 x \\ &= \frac{3x^2 \tan x}{2\sqrt{x^3-9}} + \sqrt{x^3-9} \sec^2 x \end{aligned}$$

Now, we plug these into our equation for $f'(x)$:

$$\begin{aligned} f'(x) &= \frac{1}{3} \left(\frac{\sqrt{x^3-9}\tan x}{e^{\csc x^2}} \right)^{\frac{2}{3}} \left(\frac{\sqrt{x^3-9}\tan x \frac{d}{dx} \{e^{\csc x^2}\} - e^{\csc x^2} \frac{d}{dx} \{\sqrt{x^3-9}\tan x\}}{(\tan^2 x)(x^3-9)} \right) \\ &= \frac{1}{3} \left(\frac{\sqrt{x^3-9}\tan x}{e^{\csc x^2}} \right)^{\frac{2}{3}} \cdot \\ &\quad \left(\frac{\sqrt{x^3-9}\tan x (-2x)e^{\csc x^2} \csc(x^2) \cot(x^2) - e^{\csc x^2} \left(\frac{3x^2 \tan x}{2\sqrt{x^3-9}} + \sqrt{x^3-9} \sec^2 x \right)}{(\tan^2 x)(x^3-9)} \right) \end{aligned}$$

S-35:

(a) The table below gives us a number of points on our graph, and the times they occur.

t	$(\sin t, \cos^2 t)$
0	(0, 1)
$\pi/4$	$(\frac{1}{\sqrt{2}}, \frac{1}{2})$
$\pi/2$	(1, 0)
$3\pi/4$	$(\frac{1}{\sqrt{2}}, \frac{1}{2})$
π	(0, 1)
$5\pi/4$	$(-\frac{1}{\sqrt{2}}, \frac{1}{2})$
$3\pi/2$	(-1, 0)
$7\pi/4$	$(-\frac{1}{\sqrt{2}}, \frac{1}{2})$
2π	(0, 1)

These points will repeat with a period of 2π . With this information, we have a pretty good idea of the particle's motion:

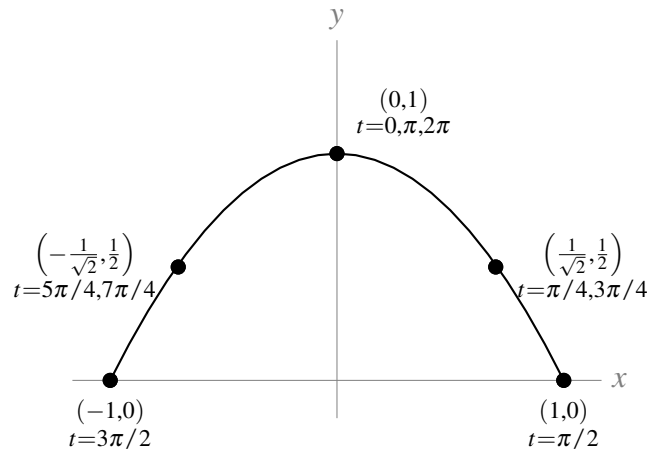

The particle traces out an arc, pointing down. It starts at $t = 0$ at the top part of the graph at $(1, 0)$, then it moves to the right until it hits $(1, 0)$ at time $t = \pi/2$. From there it reverses direction and moves along the curve to the left, hitting the top at time $t = \pi$ and reaching $(-1, 0)$ at time $t = 3\pi/2$. Then it returns to the top at $t = 2\pi$ and starts again.

So, it starts at the top of the curve, then moves back and forth along the length of the curve. It goes right first, and repeats its cycle every 2π units of time.

(b) Let $y = f(x)$ be the curve the particle traces in the xy -plane. Since x is a function of t , $y(t) = f(x(t))$. What we want to find is $\frac{df}{dx}$ when $t = \left(\frac{10\pi}{3}\right)$. Since $\frac{df}{dx}$ is a function of x , we note that when $t = \left(\frac{10\pi}{3}\right)$, $x = \sin\left(\frac{10\pi}{3}\right) = \sin\left(\frac{4\pi}{3}\right) = -\frac{\sqrt{3}}{2}$. So, the quantity we want to find (the slope of the tangent line to the curve $y = f(x)$ traced by the particle at the time $t = \left(\frac{10\pi}{3}\right)$ is given by $\frac{df}{dx}\left(-\frac{\sqrt{3}}{2}\right)$.

Using the chain rule:

$$y(t) = f(x(t))$$

$$\frac{dy}{dt} = \frac{d}{dt}\{f(x(t))\} = \frac{df}{dx} \cdot \frac{dx}{dt}$$

$$\text{so, } \frac{df}{dx} = \frac{dy}{dt} \div \frac{dx}{dt}$$

Using $y(t) = \cos^2 t$ and $x(t) = \sin t$:

$$\frac{df}{dx} = (-2 \cos t \sin t) \div (\cos t) = -2 \sin t = -2x$$

So, when $t = \frac{10\pi}{3}$ and $x = -\frac{\sqrt{3}}{2}$,

$$\frac{df}{dx}\left(-\frac{\sqrt{3}}{2}\right) = -2 \cdot \frac{-\sqrt{3}}{2} = \sqrt{3}.$$

Remark: The standard way to write this problem is to omit the notation $f(x)$, and let the variable y stand for two functions. When t is the variable, $y(t) = \cos^2 t$ gives the y -coordinate of the particle at time t . When x is the variable, $y(x)$ gives the y -coordinate of the particle given its position along the x -axis. This is an abuse of notation, because if we write $y(1)$, it is not clear whether we are referring to the y -coordinate of the particle when $t = 1$ (in this case, $y = \cos^2(1) \approx 0.3$), or the y -coordinate of the particle when $x = 1$ (in this case, looking at our table of values, $y = 0$). Although this notation is not strictly “correct,” it is very commonly used. So, you might see a solution that looks like this:

The slope of the curve is $\frac{dy}{dx}$. To find $\frac{dy}{dx}$, we use the chain rule:

$$\begin{aligned}\frac{dy}{dt} &= \frac{dy}{dx} \cdot \frac{dx}{dt} \\ \frac{d}{dt} \{\cos^2 t\} &= \frac{dy}{dx} \cdot \frac{d}{dt} \{\sin t\} \\ -2 \cos t \sin t &= \frac{dy}{dx} \cdot \cos t \\ \frac{dy}{dx} &= -2 \sin t\end{aligned}$$

So, when $t = \frac{10\pi}{3}$,

$$\frac{dy}{dx} = -2 \sin\left(\frac{10\pi}{3}\right) = -2\left(-\frac{\sqrt{3}}{2}\right) = \sqrt{3}.$$

In this case, it is up to the reader to understand when y is used as a function of t , and when it is used as a function of x . This notation (using y to be two functions, $y(t)$ and $y(x)$) is actually the accepted standard, so you should be able to understand it.

Solutions to Exercises 4.4 — Jump to [TABLE OF CONTENTS](#)

S-1: We are given that one speaker produces 3dB. So if P is the power of one speaker,

$$3 = V(P) = 10 \log_{10} \left(\frac{P}{S} \right).$$

So, for ten speakers:

$$\begin{aligned}V(10P) &= 10 \log_{10} \left(\frac{10P}{S} \right) = 10 \log_{10} \left(\frac{P}{S} \right) + 10 \log_{10}(10) \\ &= 3 + 10(1) = 13\text{dB}\end{aligned}$$

and for one hundred speakers:

$$\begin{aligned}V(100P) &= 10 \log_{10} \left(\frac{100P}{S} \right) = 10 \log_{10} \left(\frac{P}{S} \right) + 10 \log_{10}(100) \\ &= 3 + 10(2) = 23\text{dB}\end{aligned}$$

S-2: The investment doubles when it hits \$2000. So, we find the value of t that gives $A(t) = 2000$:

$$\begin{aligned}2000 &= A(t) \\2000 &= 1000e^{t/20} \\2 &= e^{t/20} \\ \log 2 &= \frac{t}{20} \\20 \log 2 &= t\end{aligned}$$

S-3: From our logarithm rules, we know that when y is *positive*, $\log(y^2) = 2 \log y$. However, the expression $\cos x$ does not always take on positive values, so (a) is not correct. (For instance, when $x = \pi$, $\log(\cos^2 x) = \log(\cos^2 \pi) = \log((-1)^2) = \log(1) = 0$, while $2 \log(\cos \pi) = 2 \log(-1)$, which does not exist.)

Because $\cos^2 x$ is never negative, we notice that $\cos^2 x = |\cos x|^2$. When $\cos x$ is nonzero, $|\cos x|$ is positive, so our logarithm rules tell us $\log(|\cos x|^2) = 2 \log |\cos x|$. When $\cos x$ is exactly zero, then both $\log(\cos^2 x)$ and $2 \log |\cos x|$ do not exist. So, $\log(\cos^2 x) = 2 \log |\cos x|$.

S-4:

- Solution 1: Using the chain rule, $\frac{d}{dx} \{\log(10x)\} = \frac{1}{10x} \cdot 10 = \frac{1}{x}$.
- Solution 2: Simplifying, $\frac{d}{dx} \{\log(10x)\} = \frac{d}{dx} \{\log(10) + \log x\} = 0 + \frac{1}{x} = \frac{1}{x}$.

S-5:

- Solution 1: Using the chain rule, $\frac{d}{dx} \{\log(x^2)\} = \frac{1}{x^2} \cdot 2x = \frac{2}{x}$.
- Solution 2: Simplifying, $\frac{d}{dx} \{\log(x^2)\} = \frac{d}{dx} \{2 \log(x)\} = \frac{2}{x}$.

S-6: Don't be fooled by a common mistake: $\log(x^2 + x)$ is *not* the same as $\log(x^2) + \log x$.

We differentiate using the chain rule: $\frac{d}{dx} \{\log(x^2 + x)\} = \frac{1}{x^2 + x} \cdot (2x + 1) = \frac{2x + 1}{x^2 + x}$.

S-7: We know the derivative of the natural logarithm (base e), so we use the base-change formula:

$$f(x) = \log_{10} x = \frac{\log x}{\log 10}$$

Since $\log 10$ is a constant:

$$f'(x) = \frac{1}{x \log 10}$$

S-8:

- Solution 1: Using the quotient rule,

$$y' = \frac{x^3 \frac{1}{x} - (\log x) \cdot 3x^2}{x^6} = \frac{x^2 - 3x^2 \log x}{x^6} = \frac{1 - 3 \log x}{x^4}.$$

- Solution 2: Using the product rule with $y = \log x \cdot x^{-3}$,

$$y' = \frac{1}{x} x^{-3} + \log x \cdot (-3)x^{-4} = x^{-4}(1 - 3 \log x)$$

S-9: Using the chain rule,

$$\begin{aligned} \frac{d}{d\theta} \log(\sec \theta) &= \frac{1}{\sec \theta} \cdot (\sec \theta \cdot \tan \theta) \\ &= \tan \theta \end{aligned}$$

Remark: the domain of the function $\log(\sec \theta)$ is those values of θ for which $\sec \theta$ is positive: so, the intervals $((2n - \frac{1}{2})\pi, (2n + \frac{1}{2})\pi)$ where n is any integer. Certainly the tangent function has a larger domain than this, but outside the domain of $\log(\sec \theta)$, $\tan \theta$ is not the derivative of $\log(\sec \theta)$.

S-10: Let's start in with the chain rule.

$$f'(x) = e^{\cos(\log x)} \cdot \frac{d}{dx} \{\cos(\log x)\}$$

We'll need the chain rule again:

$$\begin{aligned} &= e^{\cos(\log x)} (-\sin(\log x)) \cdot \frac{d}{dx} \{\log x\} \\ &= e^{\cos(\log x)} (-\sin(\log x)) \cdot \frac{1}{x} \\ &= \frac{-e^{\cos(\log x)} \sin(\log x)}{x} \end{aligned}$$

Remark: Although we have a logarithm in the exponent, we can't cancel. The expression $e^{\cos(\log x)}$ is *not* the same as the expression $x^{\cos x}$, or $\cos x$.

S-11:

$$y = \log(x^2 + \sqrt{x^4 + 1})$$

So, we'll need the chain rule:

$$\begin{aligned} y' &= \frac{\frac{d}{dx} \{x^2 + \sqrt{x^4 + 1}\}}{x^2 + \sqrt{x^4 + 1}} \\ &= \frac{2x + \frac{d}{dx} \{\sqrt{x^4 + 1}\}}{x^2 + \sqrt{x^4 + 1}} \end{aligned}$$

We need the chain rule again:

$$\begin{aligned} &= \frac{2x + \frac{d}{dx}\{x^4+1\}}{x^2 + \sqrt{x^4+1}} \\ &= \frac{2x + \frac{4x^3}{2\sqrt{x^4+1}}}{x^2 + \sqrt{x^4+1}}. \end{aligned}$$

S-12: This requires us to apply the chain rule twice.

$$\begin{aligned} \frac{d}{dx} \left\{ \sqrt{-\log(\cos x)} \right\} &= \frac{1}{2\sqrt{-\log(\cos x)}} \cdot \frac{d}{dx} \{-\log(\cos x)\} \\ &= -\frac{1}{2\sqrt{-\log(\cos x)}} \cdot \frac{1}{\cos x} \frac{d}{dx} \{\cos x\} \\ &= -\frac{1}{2\sqrt{-\log(\cos x)}} \cdot \frac{1}{\cos x} \cdot (-\sin x) \\ &= \frac{\tan x}{2\sqrt{-\log(\cos x)}} \end{aligned}$$

Remark: it looks strange to see a negative sign in the argument of a square root. Since the cosine function always gives values that are at most 1, $\log(\cos x)$ is always negative or zero over its domain. So, $\sqrt{\log(\cos x)}$ is only defined for the points where $\cos x = 1$ (and so $\log(\cos x) = 0$ —this isn't a very interesting function! In contrast, $-\log(\cos x)$ is always positive or zero over its domain—and therefore we can always take its square root.

S-13: Under the chain rule, $\frac{d}{dx} \log f(x) = \frac{1}{f(x)} f'(x)$. So

$$\begin{aligned} \frac{d}{dx} \left\{ \log(x + \sqrt{x^2+4}) \right\} &= \frac{1}{x + \sqrt{x^2+4}} \cdot \frac{d}{dx} \left\{ x + \sqrt{x^2+4} \right\} \\ &= \frac{1}{x + \sqrt{x^2+4}} \cdot \left(1 + \frac{2x}{2\sqrt{x^2+4}} \right) \\ &= \frac{1}{x + \sqrt{x^2+4}} \cdot \left(\frac{2\sqrt{x^2+4} + 2x}{2\sqrt{x^2+4}} \right) \\ &= \frac{1}{\sqrt{x^2+4}} \end{aligned}$$

S-14: Using the chain rule,

$$\begin{aligned}g'(x) &= \frac{\frac{d}{dx}\{e^{x^2} + \sqrt{1+x^4}\}}{e^{x^2} + \sqrt{1+x^4}} \\&= \frac{2xe^{x^2} + \frac{4x^3}{2\sqrt{1+x^4}}}{e^{x^2} + \sqrt{1+x^4}} \left(\frac{\sqrt{1+x^4}}{\sqrt{1+x^4}} \right) \\&= \frac{2xe^{x^2}\sqrt{1+x^4} + 2x^3}{e^{x^2}\sqrt{1+x^4} + 1+x^4}\end{aligned}$$

S-15: Using logarithm rules makes this an easier problem:

$$\begin{aligned}g(x) &= \log(2x-1) - \log(2x+1) \\ \text{So, } g'(x) &= \frac{2}{2x-1} - \frac{2}{2x+1} \\ \text{and } g'(1) &= \frac{2}{1} - \frac{2}{3} = \frac{4}{3}\end{aligned}$$

S-16: We begin by simplifying:

$$\begin{aligned}f(x) &= \log\left(\sqrt{\frac{(x^2+5)^3}{x^4+10}}\right) \\&= \log\left(\left(\frac{(x^2+5)^3}{x^4+10}\right)^{1/2}\right) \\&= \frac{1}{2}\log\left(\frac{(x^2+5)^3}{x^4+10}\right) \\&= \frac{1}{2}[\log((x^2+5)^3) - \log(x^4+10)] \\&= \frac{1}{2}[3\log((x^2+5)) - \log(x^4+10)]\end{aligned}$$

Now, we differentiate using the chain rule:

$$\begin{aligned}f'(x) &= \frac{1}{2}\left[3\frac{2x}{x^2+5} - \frac{4x^3}{x^4+10}\right] \\&= \frac{3x}{x^2+5} - \frac{2x^3}{x^4+10}\end{aligned}$$

Remark: it is a common mistake to write $\log(x^2+4)$ as $\log(x^2) + \log(4)$. These expressions are not equivalent!

S-17: We use the chain rule twice, followed by the product rule:

$$\begin{aligned}f'(x) &= \frac{1}{g(xh(x))} \cdot \frac{d}{dx}\{g(xh(x))\} \\&= \frac{1}{g(xh(x))} \cdot g'(xh(x)) \cdot \frac{d}{dx}\{xh(x)\} \\&= \frac{1}{g(xh(x))} \cdot g'(xh(x)) \cdot [h(x) + xh'(x)]\end{aligned}$$

In particular, when $x = 2$:

$$\begin{aligned}f'(2) &= \frac{1}{g(2h(2))} \cdot g'(2h(2)) \cdot [h(2) + 2h'(2)] \\&= \frac{g'(4)}{g(4)} [2 + 2 \times 3] = \frac{5}{3} [2 + 2 \times 3] \\&= \frac{40}{3}\end{aligned}$$

S-18: In the text, we saw that $\frac{d}{dx}\{a^x\} = a^x \log a$ for any constant a . So, $\frac{d}{dx}\{\pi^x\} = \pi^x \log \pi$.

By the power rule, $\frac{d}{dx}\{x^\pi\} = \pi x^{\pi-1}$.

Therefore, $g'(x) = \pi^x \log \pi + \pi x^{\pi-1}$.

Remark: we had to use two different rules for the two different terms in $g(x)$. Although the functions π^x and x^π look superficially the same, they behave differently, as do their derivatives. A function of the form $(\text{constant})^x$ is an exponential function and *not eligible for the power rule*, while a function of the form x^{constant} is exactly the class of function the power rule applies to.

S-19: We have the power rule to tell us the derivative of functions of the form x^n , where n is a constant. However, here our exponent is not a constant. Similarly, in this section we learned the derivative of functions of the form a^x , where a is a constant, but again, our base is not a constant! Although the result $\frac{d}{dx}a^x = a^x \log a$ is not what we need, the *method* used to differentiate a^x will tell us the derivative of x^x .

We'll set $g(x) = \log(x^x)$, because now we can use logarithm rules to simplify:

$$g(x) = \log(f(x)) = x \log x$$

Now, we can use the product rule to differentiate the right side, and the chain rule to differentiate $\log(f(x))$:

$$g'(x) = \frac{f'(x)}{f(x)} = \log x + x \frac{1}{x} = \log x + 1$$

Finally, we solve for $f'(x)$:

$$f'(x) = f(x)(\log x + 1) = x^x(\log x + 1)$$

S-20: In Question 19, we saw $\frac{d}{dx} \{x^x\} = x^x(\log x + 1)$. Using the base-change formula, $\log_{10}(x) = \frac{\log x}{\log 10}$. Since \log_{10} is a constant,

$$\begin{aligned} f'(x) &= \frac{d}{dx} \left\{ x^x + \frac{\log x}{\log 10} \right\} \\ &= x^x(\log x + 1) + \frac{1}{x \log 10} \end{aligned}$$

S-21: Rather than set in with a terrible chain rule problem, we'll use logarithmic differentiation. Instead of differentiating $f(x)$, we differentiate a new function $\log(f(x))$, after simplifying.

$$\begin{aligned} \log(f(x)) &= \log \sqrt[4]{\frac{(x^4 + 12)(x^4 - x^2 + 2)}{x^3}} \\ &= \frac{1}{4} \log \left(\frac{(x^4 + 12)(x^4 - x^2 + 2)}{x^3} \right) \\ &= \frac{1}{4} (\log(x^4 + 12) + \log(x^4 - x^2 + 2) - 3 \log x) \end{aligned}$$

Now that we've simplified, we can efficiently differentiate both sides. It is important to remember that we aren't differentiating $f(x)$ directly—we're differentiating $\log(f(x))$.

$$\frac{f'(x)}{f(x)} = \frac{1}{4} \left(\frac{4x^3}{x^4 + 12} + \frac{4x^3 - 2x}{x^4 - x^2 + 2} - \frac{3}{x} \right)$$

Our final step is to solve for $f'(x)$:

$$\begin{aligned} f'(x) &= f(x) \frac{1}{4} \left(\frac{4x^3}{x^4 + 12} + \frac{4x^3 - 2x}{x^4 - x^2 + 2} - \frac{3}{x} \right) \\ &= \frac{1}{4} \left(\sqrt[4]{\frac{(x^4 + 12)(x^4 - x^2 + 2)}{x^3}} \right) \left(\frac{4x^3}{x^4 + 12} + \frac{4x^3 - 2x}{x^4 - x^2 + 2} - \frac{3}{x} \right) \end{aligned}$$

It was possible to differentiate this function without logarithms, but the logarithms make it more efficient.

S-22: It's possible to do this using the product rule a number of times, but it's easier to use logarithmic differentiation. Set

$$g(x) = \log(f(x)) = \log \left[(x+1)(x^2+1)^2(x^3+1)^3(x^4+1)^4(x^5+1)^5 \right]$$

Now we can use logarithm rules to change $g(x)$ into a form that is friendlier to differentiate:

$$\begin{aligned} &= \log(x+1) + \log(x^2+1)^2 + \log(x^3+1)^3 + \log(x^4+1)^4 + \log(x^5+1)^5 \\ &= \log(x+1) + 2\log(x^2+1) + 3\log(x^3+1) + 4\log(x^4+1) + 5\log(x^5+1) \end{aligned}$$

Now, we differentiate $g(x)$ using the chain rule:

$$g'(x) = \frac{f'(x)}{f(x)} = \frac{1}{x+1} + \frac{4x}{x^2+1} + \frac{9x^2}{x^3+1} + \frac{16x^3}{x^4+1} + \frac{25x^4}{x^5+1}$$

Finally, we solve for $f'(x)$:

$$\begin{aligned} f'(x) &= f(x) \left[\frac{1}{x+1} + \frac{4x}{x^2+1} + \frac{9x^2}{x^3+1} + \frac{16x^3}{x^4+1} + \frac{25x^4}{x^5+1} \right] \\ &= (x+1)(x^2+1)^2(x^3+1)^3(x^4+1)^4(x^5+1)^5 \\ &\quad \cdot \left[\frac{1}{x+1} + \frac{4x}{x^2+1} + \frac{9x^2}{x^3+1} + \frac{16x^3}{x^4+1} + \frac{25x^4}{x^5+1} \right] \end{aligned}$$

S-23: We could do this with quotient and product rules, but it would be pretty painful. Instead, let's use a logarithm.

$$\begin{aligned} f(x) &= \left(\frac{5x^2 + 10x + 15}{3x^4 + 4x^3 + 5} \right) \left(\frac{1}{10(x+1)} \right) = \left(\frac{x^2 + 2x + 3}{3x^4 + 4x^3 + 5} \right) \left(\frac{1}{2(x+1)} \right) \\ \log(f(x)) &= \log \left[\left(\frac{x^2 + 2x + 3}{3x^4 + 4x^3 + 5} \right) \left(\frac{1}{2(x+1)} \right) \right] \\ &= \log \left(\frac{x^2 + 2x + 3}{3x^4 + 4x^3 + 5} \right) + \log \left(\frac{1}{2(x+1)} \right) \\ &= \log(x^2 + 2x + 3) - \log(3x^4 + 4x^3 + 5) - \log(x+1) - \log(2) \end{aligned}$$

Now we have a function that we can differentiate more cleanly than our original function.

$$\begin{aligned} \frac{d}{dx} \{\log(f(x))\} &= \frac{d}{dx} \{\log(x^2 + 2x + 3) - \log(3x^4 + 4x^3 + 5) - \log(x+1) - \log(2)\} \\ \frac{f'(x)}{f(x)} &= \frac{2x+2}{x^2+2x+3} - \frac{12x^3+12x^2}{3x^4+4x^3+5} - \frac{1}{x+1} \\ &= \frac{2(x+1)}{x^2+2x+3} - \frac{12x^2(x+1)}{3x^4+4x^3+5} - \frac{1}{x+1} \end{aligned}$$

Finally, we solve for $f'(x)$:

$$\begin{aligned} f'(x) &= f(x) \left(\frac{2(x+1)}{x^2+2x+3} - \frac{12x^2(x+1)}{3x^4+4x^3+5} - \frac{1}{x+1} \right) \\ &= \left(\frac{x^2+2x+3}{3x^4+4x^3+5} \right) \left(\frac{1}{2(x+1)} \right) \left(\frac{2(x+1)}{x^2+2x+3} - \frac{12x^2(x+1)}{3x^4+4x^3+5} - \frac{1}{x+1} \right) \\ &= \left(\frac{x^2+2x+3}{3x^4+4x^3+5} \right) \left(\frac{1}{x^2+2x+3} - \frac{6x^2}{3x^4+4x^3+5} - \frac{1}{2(x+1)^2} \right) \end{aligned}$$

S-24: Since $f(x)$ has the form of a function raised to a functional power, we will use logarithmic differentiation.

$$\log(f(x)) = \log((\cos x)^{\sin x}) = \sin x \cdot \log(\cos x)$$

Logarithm rules allowed us to simplify. Now, we differentiate both sides of this equation:

$$\begin{aligned}\frac{f'(x)}{f(x)} &= (\cos x) \log(\cos x) + \sin x \cdot \frac{-\sin x}{\cos x} \\ &= (\cos x) \log(\cos x) - \sin x \tan x\end{aligned}$$

Finally, we solve for $f'(x)$:

$$\begin{aligned}f'(x) &= f(x) [(\cos x) \log(\cos x) - \sin x \tan x] \\ &= (\cos x)^{\sin x} [(\cos x) \log(\cos x) - \sin x \tan x]\end{aligned}$$

Remark: negative numbers behave in a complicated manner when they are the base of an exponential expression. For example, the expression $(-1)^x$ is defined when x is the reciprocal of an odd number (like $x = \frac{1}{5}$ or $x = \frac{1}{7}$), but not when x is the reciprocal of an even number (like $x = \frac{1}{2}$). Since the domain of $f(x)$ was restricted to $(0, \frac{\pi}{2})$, $\cos x$ is always positive, and we avoid these complications.

S-25: Since $f(x)$ has the form of a function raised to a functional power, we will use logarithmic differentiation. We take the logarithm of the function, and make use of logarithm rules:

$$\log((\tan x)^x) = x \log(\tan x)$$

Now, we can differentiate:

$$\begin{aligned}\frac{\frac{d}{dx}\{(\tan x)^x\}}{(\tan x)^x} &= \log(\tan x) + x \cdot \frac{\sec^2 x}{\tan x} \\ &= \log(\tan x) + \frac{x}{\sin x \cos x}\end{aligned}$$

Finally, we solve for the derivative we want, $\frac{d}{dx}\{(\tan x)^x\}$:

$$\frac{d}{dx}\{(\tan x)^x\} = (\tan x)^x \left(\log(\tan x) + \frac{x}{\sin x \cos x} \right)$$

Remark: the restricted domain $(0, \pi/2)$ ensures that $\tan x$ is a positive number, so we avoid the problems that arise by raising a negative number to a variety of powers.

S-26: We use logarithmic differentiation.

$$\log f(x) = \log(x^2 + 1) \cdot (x^2 + 1)$$

We differentiate both sides to obtain:

$$\begin{aligned}\frac{f'(x)}{f(x)} &= \frac{d}{dx} \{ \log(x^2 + 1) \cdot (x^2 + 1) \} \\ &= \frac{2x}{x^2 + 1} (x^2 + 1) + 2x \log(x^2 + 1) \\ &= 2x(1 + \log(x^2 + 1))\end{aligned}$$

Now, we solve for $f'(x)$:

$$\begin{aligned}f'(x) &= f(x) \cdot 2x(1 + \log(x^2 + 1)) \\ &= (x^2 + 1)^{x^2 + 1} \cdot 2x(1 + \log(x^2 + 1))\end{aligned}$$

S-27: We use logarithmic differentiation: we modify our function to consider

$$\log f(x) = \log(x^2 + 1) \cdot \sin x$$

We differentiate using the product and chain rules:

$$\frac{f'(x)}{f(x)} = \frac{d}{dx} \{ \log(x^2 + 1) \cdot \sin x \} = \cos x \cdot \log(x^2 + 1) + \frac{2x \sin x}{x^2 + 1}$$

Finally, we solve for $f'(x)$

$$\begin{aligned}f'(x) &= f(x) \cdot \left(\cos x \cdot \log(x^2 + 1) + \frac{2x \sin x}{x^2 + 1} \right) \\ &= (x^2 + 1)^{\sin(x)} \cdot \left(\cos x \cdot \log(x^2 + 1) + \frac{2x \sin x}{x^2 + 1} \right)\end{aligned}$$

S-28: We differentiate using the chain rule.

$$\frac{d}{dx} \{ \log(5x^2 - 12) \} = \frac{10x}{5x^2 - 12}$$

Using the quotient rule:

$$\begin{aligned}\frac{d^2}{dx^2} \{ \log(5x^2 - 12) \} &= \frac{d}{dx} \left\{ \frac{10x}{5x^2 - 12} \right\} \\ &= \frac{(5x^2 - 12)(10) - 10x(10x)}{(5x^2 - 12)^2} \\ &= \frac{-10(5x^2 + 12)}{(5x^2 - 12)^2}\end{aligned}$$

Using the quotient rule one last time:

$$\begin{aligned}\frac{d^3}{dx^3} \{\log(5x^2 - 12)\} &= \frac{d}{dx} \left\{ \frac{-10(5x^2 + 12)}{(5x^2 - 12)^2} \right\} \\ &= \frac{(5x^2 - 12)^2(-10)(10x) + 10(5x^2 + 12)(2)(5x^2 - 12)(10x)}{(5x^2 - 12)^4} \\ &= \frac{(5x^2 - 12)(-100x) + (200x)(5x^2 + 12)}{(5x^2 - 12)^3} \\ &= \frac{100x(-5x^2 + 12 + 10x^2 + 24)}{(5x^2 - 12)^3} \\ &= \frac{100x(5x^2 + 36)}{(5x^2 - 12)^3}\end{aligned}$$

S-29: We use logarithmic differentiation; so we modify our function to consider

$$\log f(x) = \log(x) \cdot \cos^3(x)$$

Differentiating, we find:

$$\frac{f'(x)}{f(x)} = \frac{d}{dx} \{\log(x) \cdot \cos^3(x)\} = 3 \cos^2(x) \cdot (-\sin(x)) \cdot \log(x) + \frac{\cos^3(x)}{x}$$

Finally, we solve for $f'(x)$:

$$\begin{aligned}f'(x) &= f(x) \cdot \left(-3 \cos^2(x) \sin(x) \log(x) + \frac{\cos^3(x)}{x} \right) \\ &= x^{\cos^3(x)} \cdot \left(-3 \cos^2(x) \sin(x) \log(x) + \frac{\cos^3(x)}{x} \right)\end{aligned}$$

Remark: negative numbers behave in a complicated manner when they are the base of an exponential expression. For example, the expression $(-1)^x$ is defined when x is the reciprocal of an odd number (like $x = \frac{1}{5}$ or $x = \frac{1}{7}$), but not when x is the reciprocal of an even number (like $x = \frac{1}{2}$). Since the domain of $f(x)$ was restricted so that x is always positive, we avoid these complications.

S-30: We use logarithmic differentiation. So, we modify our function and consider

$$\log f(x) = (x^2 - 3) \cdot \log(3 + \sin(x)).$$

We differentiate:

$$\begin{aligned}\frac{f'(x)}{f(x)} &= \frac{d}{dx} \{(x^2 - 3) \cdot \log(3 + \sin(x))\} \\ &= 2x \log(3 + \sin(x)) + (x^2 - 3) \frac{\cos(x)}{3 + \sin(x)}\end{aligned}$$

Finally, we solve for $f'(x)$:

$$\begin{aligned} f'(x) &= f(x) \cdot \left[2x \log(3 + \sin(x)) + \frac{(x^2 - 3) \cos(x)}{3 + \sin(x)} \right] \\ &= (3 + \sin(x))^{x^2 - 3} \cdot \left[2x \log(3 + \sin(x)) + \frac{(x^2 - 3) \cos(x)}{3 + \sin(x)} \right] \end{aligned}$$

S-31: We will use logarithmic differentiation. First, we take the logarithm of our function, so we can use logarithm rules.

$$\log\left([f(x)]^{g(x)}\right) = g(x) \log(f(x))$$

Now, we differentiate. On the left side we use the chain rule, and on the right side we use product and chain rules.

$$\begin{aligned} \frac{d}{dx} \left\{ \log\left([f(x)]^{g(x)}\right) \right\} &= \frac{d}{dx} \{g(x) \log(f(x))\} \\ \frac{\frac{d}{dx} \{[f(x)]^{g(x)}\}}{[f(x)]^{g(x)}} &= g'(x) \log(f(x)) + g(x) \cdot \frac{f'(x)}{f(x)} \end{aligned}$$

Finally, we solve for the derivative of our original function.

$$\frac{d}{dx} \{[f(x)]^{g(x)}\} = [f(x)]^{g(x)} \left(g'(x) \log(f(x)) + g(x) \cdot \frac{f'(x)}{f(x)} \right)$$

Remark: in this section, we have differentiated problems of this type several times—for example, Questions 24 through 30.

S-32: Let $g(x) := \log(f(x))$. Notice $g'(x) = \frac{f'(x)}{f(x)}$.

In order to show that the two curves have horizontal tangent lines at the same values of x , we will show two things: first, that if $f(x)$ has a horizontal tangent line at some value of x , then also $g(x)$ has a horizontal tangent line at that value of x . Second, we will show that if $g(x)$ has a horizontal tangent line at some value of x , then also $f(x)$ has a horizontal tangent line at that value of x .

Suppose $f(x)$ has a horizontal tangent line where $x = x_0$ for some point x_0 . This means $f'(x_0) = 0$. Then $g'(x_0) = \frac{f'(x_0)}{f(x_0)}$. Since $f(x_0) \neq 0$, $\frac{f'(x_0)}{f(x_0)} = \frac{0}{f(x_0)} = 0$, so $g(x)$ also has a horizontal tangent line when $x = x_0$. This shows that whenever f has a horizontal tangent line, g has one too.

Now suppose $g(x)$ has a horizontal tangent line where $x = x_0$ for some point x_0 . This means $g'(x_0) = 0$. Then $g'(x_0) = \frac{f'(x_0)}{f(x_0)} = 0$, so $f'(x_0)$ exists and is equal to zero. Therefore, $f(x)$ also has a horizontal tangent line when $x = x_0$. This shows that whenever g has a horizontal tangent line, f has one too.

Remark: if we were not told that $f(x)$ gives only positive numbers, it would not necessarily be true that $f(x)$ and $\log(f(x))$ have horizontal tangent lines at the same values of x . If $f(x)$ had a horizontal tangent line at an x -value where $f(x)$ were negative, then $\log(f(x))$ would not exist there, let alone have a horizontal tangent line.

Solutions to Exercises 4.5 — Jump to [TABLE OF CONTENTS](#)

S-1: We use the power rule (a) and the chain rule (b): the power rule tells us to “bring down the 2”, and the chain rule tells us to multiply by y' .

There is no need for the quotient rule here, as there are no quotients. Exponential functions have the form $(\text{constant})^{\text{function}}$, but our function has the form $(\text{function})^{\text{constant}}$, so we did not use (d).

S-2: At $(0, 4)$ and $(0, -4)$, the curve looks to be horizontal, if you zoom in: a tangent line here would have derivative zero. At the origin, the curve looks like its tangent line is vertical, so $\frac{dy}{dx}$ does not exist.

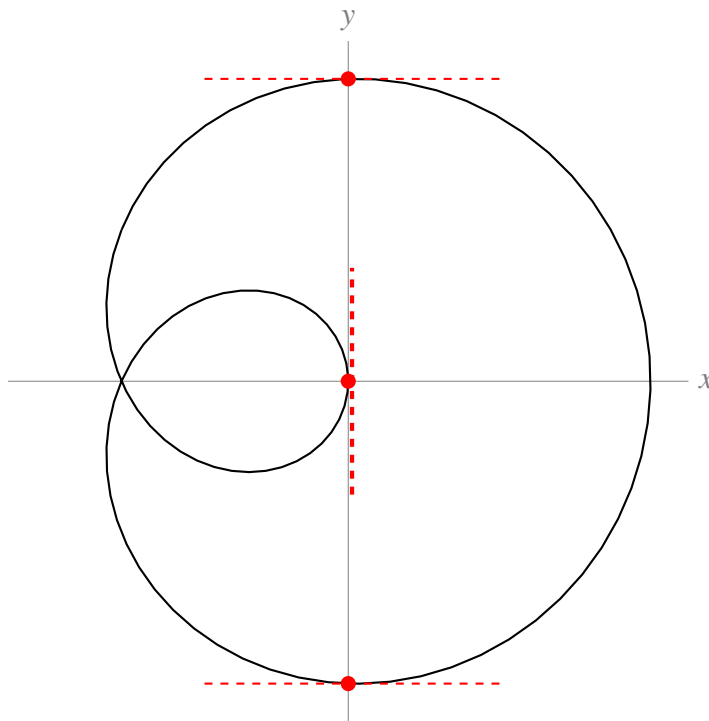

S-3: (a) No. A function must pass the vertical line test: one input cannot result in two (or more) outputs. Since one value of x sometimes corresponds to two values of y (for example, when $x = \pi/4$, y is $\pm 1/\sqrt{2}$), there is no function $f(x)$ so that $y = f(x)$ captures every point on the circle.

Remark: $y = \pm\sqrt{1-x^2}$ does capture every point on the unit circle. However, since one input x sometimes results in two outputs y , this expression is not a function.

(b) No, for the same reasons as (a). If $f'(x)$ is a function, then it can give at most one slope corresponding to one value of x . Since one value of x can correspond to two points on the circle with different slopes, $f'(x)$ cannot give the slope of every point on the circle. For example, fix any $0 < a < 1$. There are two points on the circle with x -coordinate equal to a . At the upper one, the slope is strictly negative. At the lower one, the slope is strictly positive.

(c) We differentiate:

$$2x + 2y \frac{dy}{dx} = 0$$

and solve for $\frac{dy}{dx}$

$$\frac{dy}{dx} = -\frac{x}{y}$$

But there is a y in the right-hand side of this equation, and it's not clear how to get it out. Our answer in (b) tells us that, actually, we *can't* get it out, if we want the right-hand side to be a function of x . The derivative cannot be expressed as a function of x , because one value of x corresponds to multiple points on the circle.

Remark: since $y = \pm\sqrt{1-x^2}$, we could try writing

$$\frac{dy}{dx} = -\frac{x}{y} = \pm \frac{x}{\sqrt{1-x^2}}$$

but this is not a *function* of x . Again, in a function, one input leads to at most one output, but here one value of x will usually lead to two values of $\frac{dy}{dx}$.

S-4: The derivative $\frac{dy}{dx}$ is $\frac{11}{4}$ only at the point $(1,3)$: it is not *constantly* $\frac{11}{4}$, so it is wrong to differentiate the constant $\frac{11}{4}$ to find $\frac{d^2y}{dx^2}$. Below is a correct solution.

$$-28x + 2y + 2xy' + 2yy' = 0$$

Plugging in $x = 1, y = 3$:

$$\begin{aligned} -28 + 6 + 2y' + 6y' &= 0 \\ y' &= \frac{11}{4} \quad \text{at the point } (1,3) \end{aligned}$$

Differentiating **the equation** $-28x + 2y + 2xy' + 2yy' = 0$:

$$\begin{aligned} -28 + 2y' + 2y' + 2xy'' + 2y'y' + 2yy'' &= 0 \\ 4y' + 2(y')^2 + 2xy'' + 2yy'' &= 28 \end{aligned}$$

At the point $(1,3)$, $y' = \frac{11}{4}$. Plugging in:

$$\begin{aligned} 4\left(\frac{11}{4}\right) + 2\left(\frac{11}{4}\right)^2 + 2(1)y'' + 2(3)y'' &= 28 \\ y'' &= \frac{15}{64} \end{aligned}$$

S-5: Remember that y is a function of x . We begin with implicit differentiation.

$$xy + e^x + e^y = 1$$
$$y + x \frac{dy}{dx} + e^x + e^y \frac{dy}{dx} = 0$$

Now, we solve for $\frac{dy}{dx}$.

$$x \frac{dy}{dx} + e^y \frac{dy}{dx} = -(e^x + y)$$
$$(x + e^y) \frac{dy}{dx} = -(e^x + y)$$
$$\frac{dy}{dx} = -\frac{e^x + y}{e^y + x}$$

S-6: Differentiate both sides of the equation with respect to x :

$$e^y \frac{dy}{dx} = x \cdot 2y \frac{dy}{dx} + y^2 + 1$$

Now, get the derivative on one side and solve

$$e^y \frac{dy}{dx} - 2xy \frac{dy}{dx} = y^2 + 1$$
$$\frac{dy}{dx} (e^y - 2xy) = y^2 + 1$$
$$\frac{dy}{dx} = \frac{y^2 + 1}{e^y - 2xy}$$

S-7:

- First we find the x -coordinates where $y = 1$.

$$x^2 \tan\left(\frac{\pi}{4}\right) + 2x \log(1) = 16$$
$$x^2 \cdot 1 + 2x \cdot 0 = 16$$
$$x^2 = 16$$

So $x = \pm 4$.

- Now we use implicit differentiation to get y' in terms of x, y :

$$x^2 \tan(\pi y/4) + 2x \log(y) = 16$$
$$2x \tan(\pi y/4) + x^2 \frac{\pi}{4} \sec^2(\pi y/4) \cdot y' + 2 \log(y) + \frac{2x}{y} \cdot y' = 0.$$

- Now set $y = 1$ and use $\tan(\pi/4) = 1$, $\sec(\pi/4) = \sqrt{2}$ to get

$$2x \tan(\pi/4) + x^2 \frac{\pi}{4} \sec^2(\pi/4) y' + 2 \log(1) + 2x \cdot y' = 0$$

$$2x + \frac{\pi}{2} x^2 y' + 2x y' = 0$$

$$y' = -\frac{2x}{x^2 \pi/2 + 2x} = -\frac{4}{\pi x + 4}$$

- So at $(x, y) = (4, 1)$ we have $y' = -\frac{4}{4\pi + 4} = -\frac{1}{\pi + 1}$

- and at $(x, y) = (-4, 1)$ we have $y' = \frac{1}{\pi - 1}$

S-8:

$$x^2 + x + y = \sin(xy)$$

We differentiate implicitly. For ease of notation, we write y' for $\frac{dy}{dx}$.

$$2x + 1 + y' = \cos(xy)(y + xy')$$

We're interested in y'' , so we implicitly differentiate again.

$$2 + y'' = -\sin(xy)(y + xy')^2 + \cos(xy)(2y' + xy'')$$

We want to know what y'' is when $x = y = 0$. Plugging these in yields the following:

$$2 + y'' = 2y'$$

So, we need to know what y' is when $x = y = 0$. We can get this from the equation $2x + 1 + y' = \cos(xy)(y + xy')$, which becomes $1 + y' = 0$ when $x = y = 0$. So, at the origin, $y' = -1$, and

$$\begin{aligned} 2 + y'' &= 2(-1) \\ y'' &= -4 \end{aligned}$$

Remark: a common mistake is to stop at the equation $2x + 1 + y' = \cos(xy)(y + xy')$, plug in $x = y = 0$, find $y' = -1$, and decide $y'' = \frac{d}{dx}\{-1\} = 0$. This is due to a slight sloppiness in the usual notation. When we wrote $y' = 1$, what we meant is that *at the point* $(0, 0)$, $\frac{dy}{dx} = -1$. More properly written: $\left. \frac{dy}{dx} \right|_{x=0, y=0} = -1$. This is not the same as saying $y' = 1$ everywhere (in which case, indeed, y'' would be 0 everywhere).

S-9: Differentiate the equation and solve:

$$3x^2 + 4y^3 \frac{dy}{dx} = -\sin(x^2 + y) \cdot \left(2x + \frac{dy}{dx}\right)$$
$$\frac{dy}{dx} = -\frac{2x \sin(x^2 + y) + 3x^2}{4y^3 + \sin(x^2 + y)}$$

S-10:

- First we find the x -coordinates where $y = 0$.

$$x^2 e^0 + 4x \cos(0) = 5$$
$$x^2 + 4x - 5 = 0$$
$$(x + 5)(x - 1) = 0$$

So $x = 1, -5$.

- Now we use implicit differentiation to get y' in terms of x, y :

$$x^2 e^y + 4x \cos(y) = 5 \quad \text{differentiate both sides}$$
$$x^2 \cdot e^y \cdot y' + 2x e^y + 4x(-\sin(y)) \cdot y' + 4 \cos(y) = 0$$

- Now set $y = 0$ to get

$$x^2 \cdot e^0 \cdot y' + 2x e^0 + 4x(-\sin(0)) \cdot y' + 4 \cos(0) = 0$$
$$x^2 y' + 2x + 4 = 0$$
$$y' = -\frac{4 + 2x}{x^2}.$$

- So at $(x, y) = (1, 0)$ we have $y' = -6$,
- and at $(x, y) = (-5, 0)$ we have $y' = \frac{6}{25}$.

S-11: We use implicit differentiation, twice.

$$2x + 2yy' = 0$$
$$2 + (2y)y'' + (2y')y' = 0$$
$$y'' = -\frac{(y')^2 + 1}{y}$$

So, we need an expression for y' . We use the equation $2x + 2yy' = 0$ to conclude $y' = -\frac{x}{y}$:

$$\begin{aligned}y'' &= -\frac{\left(-\frac{x}{y}\right)^2 + 1}{y} \\ &= -\frac{\frac{x^2}{y^2} + 1}{y} \\ &= -\frac{x^2 + y^2}{y^3} \\ &= -\frac{1}{y^3}\end{aligned}$$

S-12: Differentiate the equation and solve:

$$\begin{aligned}2x + 2y \frac{dy}{dx} &= \cos(x+y) \cdot \left(1 + \frac{dy}{dx}\right) \\ \frac{dy}{dx} &= \frac{\cos(x+y) - 2x}{2y - \cos(x+y)}\end{aligned}$$

S-13:

- First we find the x -coordinates where $y = 0$.

$$\begin{aligned}x^2 \cos(0) + 2xe^0 &= 8 \\ x^2 + 2x - 8 &= 0 \\ (x+4)(x-2) &= 0\end{aligned}$$

So $x = 2, -4$.

- Now we use implicit differentiation to get y' in terms of x, y :

$$\begin{aligned}x^2 \cos(y) + 2xe^y &= 8 && \text{differentiate both sides} \\ x^2 \cdot (-\sin y) \cdot y' + 2x \cos y + 2xe^y \cdot y' + 2e^y &= 0\end{aligned}$$

- Now set $y = 0$ to get

$$\begin{aligned}x^2 \cdot (-\sin 0) \cdot y' + 2x \cos 0 + 2xe^0 \cdot y' + 2e^0 &= 0 \\ 0 + 2x + 2xy' + 2 &= 0 \\ y' &= -\frac{2+2x}{2x} = -\frac{1+x}{x}\end{aligned}$$

- So at $(x, y) = (2, 0)$ we have $y' = -\frac{3}{2}$,
- and at $(x, y) = (-4, 0)$ we have $y' = -\frac{3}{4}$.

S-14: The question asks at which points on the ellipse $\frac{dy}{dx} = 1$. So, we begin by differentiating, implicitly:

$$2x + 6y \frac{dy}{dx} = 0$$

We could solve for $\frac{dy}{dx}$ at this point, but it's not necessary. We want to know when $\frac{dy}{dx}$ is equal to one:

$$\begin{aligned} 2x + 6y(1) &= 0 \\ x &= -3y \end{aligned}$$

That is, $\frac{dy}{dx} = 1$ at those points along the ellipse where $x = -3y$. We plug this into the equation of the ellipse to find the coordinates of these points.

$$\begin{aligned} (-3y)^2 + 3y^2 &= 1 \\ 12y^2 &= 1 \\ y &= \pm \frac{1}{\sqrt{12}} = \pm \frac{1}{2\sqrt{3}} \end{aligned}$$

So, the points along the ellipse where the tangent line is parallel to the line $y = x$ occur when $y = \frac{1}{2\sqrt{3}}$ and $x = -3y$, and when $y = \frac{-1}{2\sqrt{3}}$ and $x = -3y$. That is, the points $\left(\frac{-\sqrt{3}}{2}, \frac{1}{2\sqrt{3}}\right)$ and $\left(\frac{\sqrt{3}}{2}, \frac{-1}{2\sqrt{3}}\right)$.

S-15: First, we differentiate implicitly with respect to x .

$$\begin{aligned} \sqrt{xy} &= x^2y - 2 \\ \frac{1}{2\sqrt{xy}} \cdot \frac{d}{dx}\{xy\} &= (2x)y + x^2 \frac{dy}{dx} \\ \frac{y + x \frac{dy}{dx}}{2\sqrt{xy}} &= 2xy + x^2 \frac{dy}{dx} \end{aligned}$$

Now, we plug in $x = 1$, $y = 4$, and solve for $\frac{dy}{dx}$:

$$\begin{aligned} \frac{4 + \frac{dy}{dx}}{4} &= 8 + \frac{dy}{dx} \\ \frac{dy}{dx} &= -\frac{28}{3} \end{aligned}$$

S-16: Implicitly differentiating $x^2y(x)^2 + x\sin(y(x)) = 4$ with respect to x gives

$$2xy^2 + 2x^2yy' + \sin y + xy' \cos y = 0$$

Then we gather the terms containing y' on one side, so we can solve for y' :

$$\begin{aligned}2x^2yy' + xy' \cos y &= -2xy^2 - \sin y \\y'(2x^2y + x \cos y) &= -2xy^2 - \sin y \\y' &= -\frac{2xy^2 + \sin y}{2x^2y + x \cos y}\end{aligned}$$

S-17:

$$\begin{aligned}f(x) &= x \log x - x \\f'(x) &= \log x + x \cdot \frac{1}{x} - 1 \\&= \log x \\f''(x) &= \frac{1}{x}\end{aligned}$$

S-18:

- First we find the x -ordinates where $y = 0$.

$$\begin{aligned}x^2 + (1)e^0 &= 5 \\x^2 + 1 &= 5 \\x^2 &= 4\end{aligned}$$

So $x = 2, -2$.

- Now we use implicit differentiation to get y' in terms of x, y :

$$2x + (y + 1)e^y \frac{dy}{dx} + e^y \frac{dy}{dx} = 0$$

- Now set $y = 0$ to get

$$\begin{aligned}2x + (0 + 1)e^0 \frac{dy}{dx} + e^0 \frac{dy}{dx} &= 0 \\2x + \frac{dy}{dx} + \frac{dy}{dx} &= 0 \\2x &= -2 \frac{dy}{dx} \\x &= -\frac{dy}{dx}\end{aligned}$$

- So at $(x,y) = (2,0)$ we have $y' = -2$,
- and at $(x,y) = (-2,0)$ we have $y' = 2$.

S-19: The slope of the tangent line is, of course, given by the derivative, so let's start by finding $\frac{dy}{dx}$ of both shapes.

For the circle, we differentiate implicitly

$$2x + 2y \frac{dy}{dx} = 0$$

and solve for $\frac{dy}{dx}$

$$\frac{dy}{dx} = -\frac{x}{y}$$

For the ellipse, we also differentiate implicitly:

$$2x + 6y \frac{dy}{dx} = 0$$

and solve for $\frac{dy}{dx}$

$$\frac{dy}{dx} = -\frac{x}{3y}$$

What we want is a value of x where both derivatives are equal. However, they might have different values of y , so let's let y_1 be the y -values associated with x on the circle, and let y_2 be the y -values associated with x on the ellipse. That is, $x^2 + y_1^2 = 1$ and $x^2 + 3y_2^2 = 1$. For the slopes at (x, y_1) on the circle and (x, y_2) on the ellipse to be equal, we need:

$$\begin{aligned} -\frac{x}{y_1} &= -\frac{x}{3y_2} \\ x \left(\frac{1}{y_1} - \frac{1}{3y_2} \right) &= 0 \end{aligned}$$

So $x = 0$ or $y_1 = 3y_2$. Let's think about which x -values will have a y -coordinate of the circle be three times as large as a y -coordinate of the ellipse. If $y_1 = 3y_2$, (x, y_1) is on the circle, and (x, y_2) is on the ellipse, then $x^2 + y_1^2 = x^2 + (3y_2)^2 = 1$ and $x^2 + 3y_2^2 = 1$. In this case:

$$\begin{aligned} x^2 + 9y_2^2 &= x^2 + 3y_2^2 \\ 9y_2^2 &= 3y_2^2 \\ y_2 &= 0 \\ x &= \pm 1 \end{aligned}$$

We need to be a tiny bit careful here: when $y = 0$, y' is not defined for either curve. For both curves, when $y = 0$, the tangent lines are vertical (and so have no real-valued slope!). Two vertical lines are indeed parallel.

So, for $x = 0$ and for $x = \pm 1$, the two curves have parallel tangent lines.

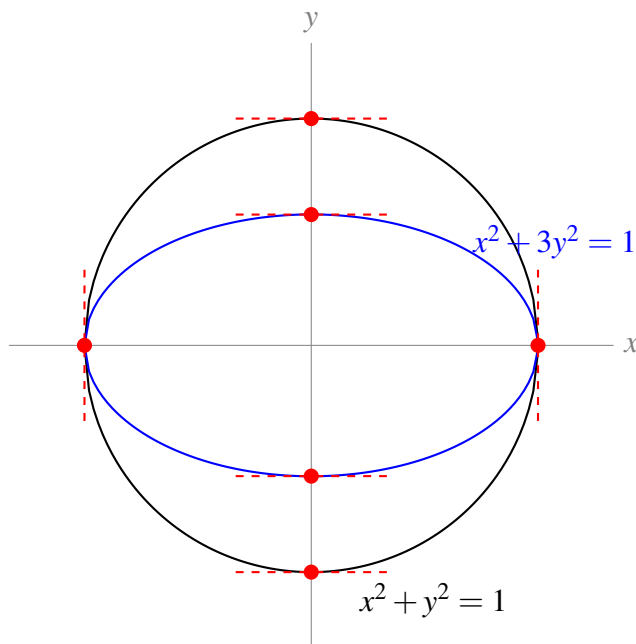

S-20:

(a) We differentiate implicitly.

$$x^3y(x) + y(x)^3 = 10x$$

$$3x^2y(x) + x^3y'(x) + 3y(x)^2y'(x) = 10$$

Subbing in $x = 1$ and $y(1) = 2$ gives

$$(3)(1)(2) + (1)y'(1) + (3)(4)y'(1) = 10$$

$$13y'(1) = 4$$

$$y'(1) = \frac{4}{13}$$

(b) From part (a), the slope of the curve at $x = 1$, $y = 2$ is $\frac{4}{13}$, so the curve is increasing, but fairly slowly. The angle of the tangent line is $\tan^{-1}\left(\frac{4}{13}\right) \approx 17^\circ$. We are also told that $y''(1) < 0$. So the slope of the curve is decreasing as x passes through 1. That is, the line is more steeply increasing to the left of $x = 1$, and its slope is decreasing (getting less steep, then possibly the slope even becomes negative) as we move past $x = 1$.

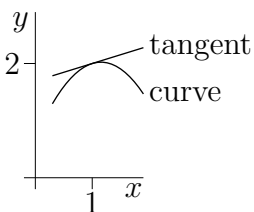

No exercises for Section 4.6. — Jump to [TABLE OF CONTENTS](#)

Solutions to Exercises 4.7 — Jump to [TABLE OF CONTENTS](#)

S-1: (a) We can plug any number into the cosine function, and it will return a number in $[-1, 1]$. The domain of $\arcsin x$ is $[-1, 1]$, so any number we plug into cosine will give us a valid number to plug into arcsine. So, the domain of $f(x)$ is all real numbers.

(b) We can plug any number into the cosine function, and it will return a number in $[-1, 1]$. The domain of $\operatorname{arccsc} x$ is $(-\infty, -1] \cup [1, \infty)$, so in order to have a valid number to plug into arccosecant, we need $\cos x = \pm 1$. That is, the domain of $g(x)$ is all values $x = n\pi$ for some integer n .

(c) The domain of arccosine is $[-1, 1]$. The domain of sine is all real numbers, so no matter what number arccosine spits out, we can safely plug it into sine. So, the domain of $h(x)$ is $[-1, 1]$.

S-2: False: $\cos t = 1$ for infinitely many values of t ; arccosine gives only the single value $t = 0$ for which $\cos t = 1$ and $0 \leq t \leq \pi$. The particle does not start moving until $t = 10$, so $t = 0$ is not in the domain of the function describing its motion.

The particle will have height 1 at time $2\pi n$, for any integer $n \geq 2$.

S-3: First, we restrict the domain of f to force it to be one-to-one. There are many intervals we could choose over which f is one-to-one, but the question asks us to contain $x = 0$ and be as large as possible; this leaves us with the following restricted function:

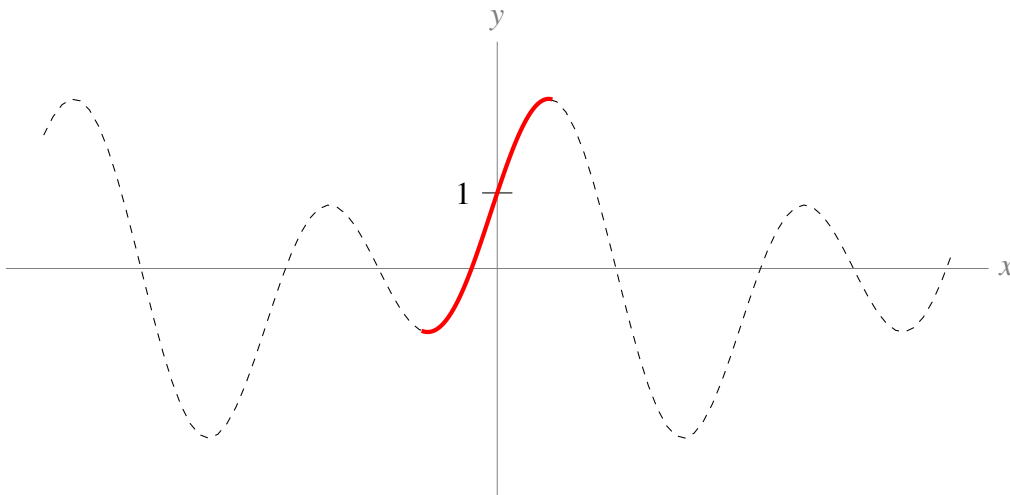

The inverse of a function swaps the role of the input and output; so if the graph of $y = f(x)$ contains the point (a, b) , then the graph of $Y = f^{-1}(X)$ contains the point (b, a) . That is, the graph of $Y = f^{-1}(X)$ is the graph of $y = f(x)$ with the x -coordinates and y -coordinates swapped. (So, since $y = f(x)$ crosses the y -axis at $y = 1$, then $Y = f^{-1}(X)$ crosses the X -axis at $X = 1$.) This swapping is equivalent to reflecting the curve $y = f(x)$ over the line $y = x$.

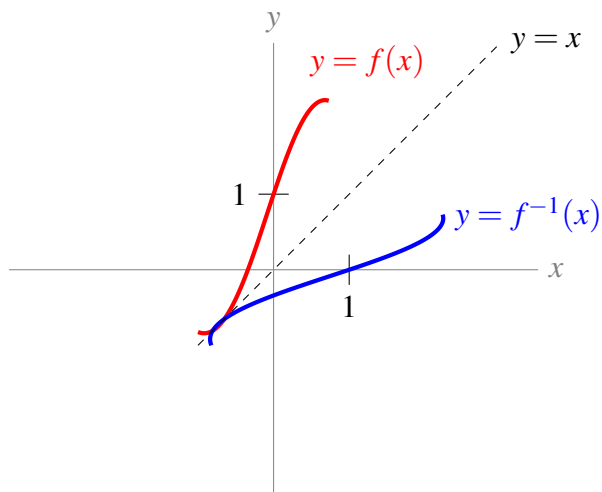

Remark: while you're getting accustomed to inverse functions, it is sometimes clearer to consider $y = f(x)$ and $Y = f^{-1}(X)$: using slightly different notations for x (the input of f , hence the output of f^{-1}) and X (the input of f^{-1} , which comes from the output of f). However, the convention is to use x for the inputs of both functions, and y as the outputs of both functions, as is written on the graph above.

S-4: The tangent line is horizontal when $0 = y' = a - \sin x$. That is, when $a = \sin x$.

- If $|a| > 1$, then there is no value of x for which $a = \sin x$, so the curve has no horizontal tangent lines.
- If $|a| = 1$, then there are infinitely many solutions to $a = \sin x$, but only one solution in the interval $[-\pi, \pi]$: $x = \arcsin(a) = \arcsin(\pm 1) = \pm \frac{\pi}{2}$. Then the values of x for which $a = \sin x$ are $x = 2\pi n + a\frac{\pi}{2}$ for any integer n .
- If $|a| < 1$, then there are infinitely many solutions to $a = \sin x$. The solution in the interval $(-\frac{\pi}{2}, \frac{\pi}{2})$ is given by $x = \arcsin(a)$. The other solution in the interval $(-\pi, \pi)$ is given by $x = \pi - \arcsin(a)$, as shown in the unit circles below.

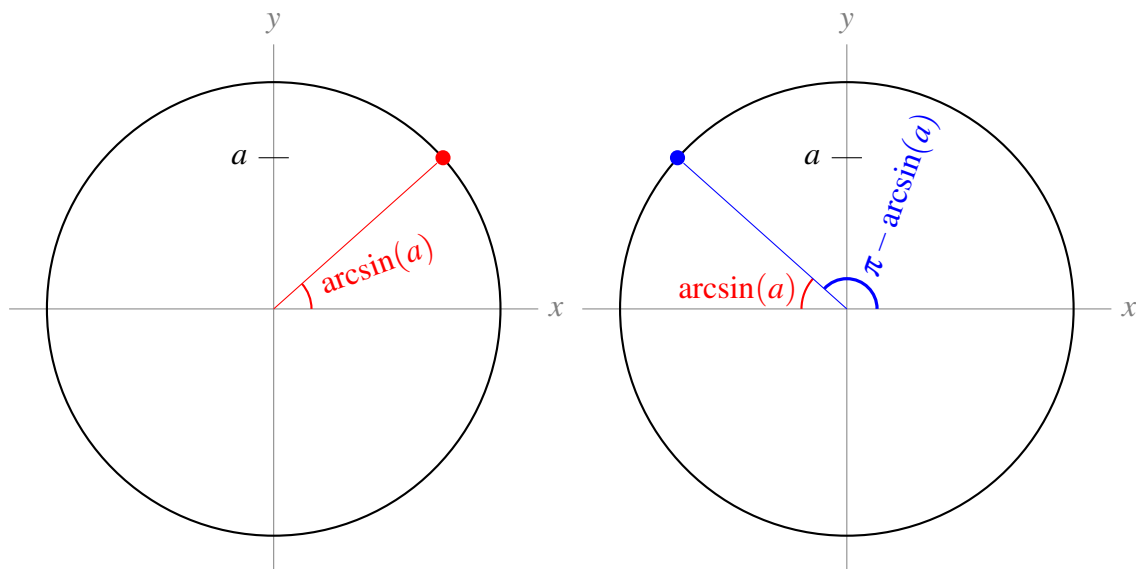

So, the values of x for which $x = \sin a$ are $x = 2\pi n + \arcsin(a)$ and $x = 2\pi n + \pi - \arcsin(a)$ for any integer n .

Remark: when $a = 1$, then

$$2\pi n + \arcsin(a) = 2\pi n + \frac{\pi}{2} = 2\pi n + \pi - \left(\frac{\pi}{2}\right) = 2\pi n + \pi - \arcsin(a).$$

Similarly, when $a = -1$,

$$2\pi n + \arcsin(a) = 2\pi n - \frac{\pi}{2} = 2\pi(n-1) + \pi - \left(-\frac{\pi}{2}\right) = 2\pi(n-1) + \pi - \arcsin(a).$$

So, if we try to use the descriptions in the third bullet point to describe points where the tangent line is horizontal when $|a| = 1$, we get the correct points but each point is listed twice. This is why we separated the case $|a| = 1$ from the case $|a| < 1$.

S-5: The function $\arcsin x$ is only defined for $|x| \leq 1$, and the function $\operatorname{arccsc} x$ is only defined for $|x| \geq 1$, so $f(x)$ has domain $|x| = 1$. That is, $x = \pm 1$.

In order for $f(x)$ to be differentiable at a point, it must exist in an open interval around that point. (See Definition 3.3.3.) Since our function does not exist over any open interval, $f(x)$ is not differentiable anywhere.

So, actually, $f(x)$ is a pretty boring function, which we can entirely describe as: $f(-1) = -\pi$ and $f(1) = \pi$.

S-6: Using the chain rule,

$$\begin{aligned} \frac{d}{dx} \left\{ \arcsin \left(\frac{x}{3} \right) \right\} &= \frac{1}{\sqrt{1 - \left(\frac{x}{3}\right)^2}} \cdot \frac{1}{3} \\ &= \frac{1}{3\sqrt{1 - \frac{x^2}{9}}} \\ &= \frac{1}{\sqrt{9 - x^2}} \end{aligned}$$

Since the domain of arcsine is $[-1, 1]$, and we are plugging in $\frac{x}{3}$ to arcsine, the values of x that we can plug in are those that satisfy $-1 \leq \frac{x}{3} \leq 1$, or $-3 \leq x \leq 3$. So the domain of f is $[-3, 3]$.

S-7: Using the quotient rule,

$$\frac{d}{dt} \left\{ \frac{\operatorname{arccost} t}{t^2 - 1} \right\} = \frac{(t^2 - 1) \left(\frac{-1}{\sqrt{1-t^2}} \right) - (\operatorname{arccost} t)(2t)}{(t^2 - 1)^2}$$

The domain of arccosine is $[-1, 1]$, and since $t^2 - 1$ is in the denominator, the domain of f requires $t^2 - 1 \neq 0$, that is, $t \neq \pm 1$. So the domain of $f(t)$ is $(-1, 1)$.

S-8: The domain of $\operatorname{arcsec} x$ is $|x| \geq 1$: that is, we can plug into arcsecant only values with absolute value greater than or equal to one. Since $-x^2 - 2 \leq -2$, every real value of x gives us an acceptable value to plug into arcsecant. So, the domain of $f(x)$ is all real numbers.

To differentiate, we use the chain rule. Remember $\frac{d}{dx} \{\operatorname{arcsec} x\} = \frac{1}{|x|\sqrt{x^2-1}}$.

$$\begin{aligned} \frac{d}{dx} \{\operatorname{arcsec}(-x^2-2)\} &= \frac{1}{|-x^2-2|\sqrt{(-x^2-2)^2-1}} \cdot (-2x) \\ &= \frac{-2x}{(x^2+2)\sqrt{x^4+4x+3}}. \end{aligned}$$

S-9: We use the chain rule, remembering that a is a constant.

$$\begin{aligned} \frac{d}{dx} \left\{ \frac{1}{a} \arctan \left(\frac{x}{a} \right) \right\} &= \frac{1}{a} \cdot \frac{1}{1 + \left(\frac{x}{a}\right)^2} \cdot \frac{1}{a} \\ &= \frac{1}{a^2 + x^2} \end{aligned}$$

The domain of arctangent is all real numbers, so the domain of $f(x)$ is also all real numbers.

S-10: We differentiate using the **product** and **chain** rules.

$$\begin{aligned} \frac{d}{dx} \left\{ x \arcsin x + \sqrt{1-x^2} \right\} &= \arcsin x + \frac{x}{\sqrt{1-x^2}} + \frac{-2x}{2\sqrt{1-x^2}} \\ &= \arcsin x \end{aligned}$$

The domain of $\arcsin x$ is $[-1, 1]$, and the domain of $\sqrt{1-x^2}$ is all values of x so that $1-x^2 \geq 0$, so x in $[-1, 1]$. Therefore, the domain of $f(x)$ is $[-1, 1]$.

S-11: We differentiate using the chain rule:

$$\frac{d}{dx} \{\arctan(x^2)\} = \frac{2x}{1+x^4}$$

This is zero exactly when $x = 0$.

S-12: Using formulas you should memorize from this section,

$$\frac{d}{dx} \{\arcsin x + \arccos x\} = \frac{1}{\sqrt{1-x^2}} + \frac{-1}{\sqrt{1-x^2}} = 0$$

Remark: the only functions with derivative equal to zero everywhere are constant functions, so $\arcsin x + \arccos x$ should be a constant. Since $\sin \theta = \cos \left(\frac{\pi}{2} - \theta \right)$, we can set

$$\sin \theta = x \qquad \cos \left(\frac{\pi}{2} - \theta \right) = x$$

where x and θ are the same in both expressions, and $-\frac{\pi}{2} \leq \theta \leq \frac{\pi}{2}$. Then

$$\arcsin x = \theta \qquad \arccos x = \frac{\pi}{2} - \theta$$

We note here that arcsine is the inverse of the sine function *restricted to* $[-\frac{\pi}{2}, \frac{\pi}{2}]$. So, since we restricted θ to this domain, $\sin \theta = x$ really does imply $\arcsin x = \theta$. (For an example of why this matters, note $\sin(2\pi) = 0$, but $\arcsin(0) = 0 \neq 2\pi$.) Similarly, arccosine is the inverse of the cosine function restricted to $[0, \pi]$. Since $-\frac{\pi}{2} \leq \theta \leq \frac{\pi}{2}$, then $0 \leq (\frac{\pi}{2} - \theta) \leq \pi$, so $\cos(\frac{\pi}{2} - \theta) = x$ really does imply $\arccos x = \frac{\pi}{2} - \theta$.

So,

$$\arcsin x + \arccos x = \theta + \frac{\pi}{2} - \theta = \frac{\pi}{2}$$

which means the derivative we were calculating was actually just $\frac{d}{dx} \left\{ \frac{\pi}{2} \right\} = 0$.

S-13: Using the chain rule,

$$y' = \frac{-\frac{1}{x^2}}{\sqrt{1 - (\frac{1}{x})^2}} = \frac{-1}{x^2 \sqrt{1 - \frac{1}{x^2}}}.$$

S-14:

$$\begin{aligned} \frac{d}{dx} \{ \arctan x \} &= \frac{1}{1 + x^2} \\ \frac{d}{dx} \left\{ \frac{1}{1 + x^2} \right\} &= \frac{d}{dx} \{ (1 + x^2)^{-1} \} \\ &= (-1)(1 + x^2)^{-2}(2x) \\ &= \frac{-2x}{(1 + x^2)^2} \end{aligned}$$

S-15: Using the chain rule,

$$y' = \frac{-\frac{1}{x^2}}{1 + (\frac{1}{x})^2} = \frac{-1}{x^2 + 1}.$$

S-16: Using the product rule:

$$\begin{aligned} \frac{d}{dx} \{ (1 + x^2) \arctan x \} &= 2x \arctan x + (1 + x^2) \frac{1}{1 + x^2} \\ &= 2x \arctan x + 1 \end{aligned}$$

S-17: Let $\theta = \arctan x$. Then θ is the angle of a right triangle that gives $\tan \theta = x$. In particular, the ratio of the opposite side to the adjacent side is x . So, we have a triangle that looks like this:

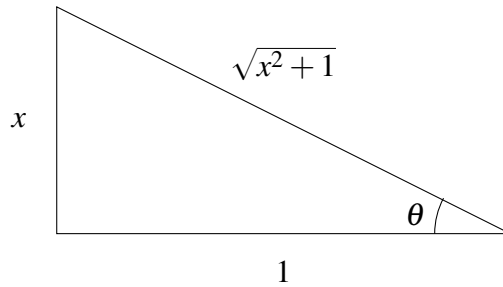

where the length of the hypotenuse came from the Pythagorean Theorem. Now,

$$\sin(\arctan x) = \sin \theta = \frac{\text{opp}}{\text{hyp}} = \frac{x}{\sqrt{x^2 + 1}}$$

From here, we differentiate using the quotient rule:

$$\begin{aligned} \frac{d}{dx} \left\{ \frac{x}{\sqrt{x^2 + 1}} \right\} &= \frac{\sqrt{x^2 + 1} - x \frac{2x}{2\sqrt{x^2 + 1}}}{x^2 + 1} \\ &= \left(\frac{\sqrt{x^2 + 1} - \frac{x^2}{\sqrt{x^2 + 1}}}{x^2 + 1} \right) \cdot \frac{\sqrt{x^2 + 1}}{\sqrt{x^2 + 1}} \\ &= \frac{(x^2 + 1) - x^2}{(x^2 + 1)^{3/2}} \\ &= \frac{1}{(x^2 + 1)^{3/2}} = (x^2 + 1)^{-3/2} \end{aligned}$$

Remark: another strategy is to differentiate first, using the chain rule, then draw a triangle to simplify the resulting expression $\frac{d}{dx} \{ \sin(\arctan x) \} = \frac{\cos(\arctan x)}{1 + x^2}$.

S-18:

Let $\theta = \arcsin x$. Then θ is the angle of a right triangle that gives $\sin \theta = x$. In particular, the ratio of the opposite side to the hypotenuse is x . So, we have a triangle that looks like this:

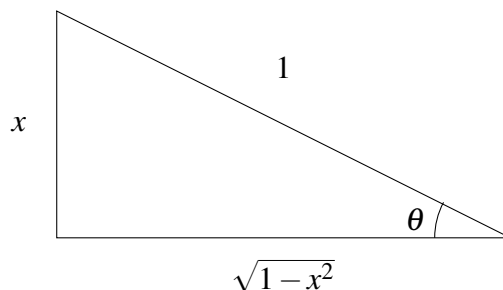

where the length of the adjacent side came from the Pythagorean Theorem. Now,

$$\cot(\arcsin x) = \cot \theta = \frac{\text{adj}}{\text{opp}} = \frac{\sqrt{1 - x^2}}{x}$$

From here, we differentiate using the quotient rule:

$$\begin{aligned} \frac{d}{dx} \left\{ \frac{\sqrt{1-x^2}}{x} \right\} &= \frac{x \frac{-2x}{2\sqrt{1-x^2}} - \sqrt{1-x^2}}{x^2} \\ &= \frac{-x^2 - (1-x^2)}{x^2 \sqrt{1-x^2}} \\ &= \frac{-1}{x^2 \sqrt{1-x^2}} \end{aligned}$$

Remark: another strategy is to differentiate first, using the chain rule, then draw a triangle to simplify the resulting expression $\frac{d}{dx} \{ \cot(\arcsin x) \} = \frac{-\csc^2(\arcsin x)}{\sqrt{1-x^2}}$.

S-19: The line $y = 2x + 9$ has slope 2, so we must find all values of x between -1 and 1 ($\arcsin x$ is only defined for these values of x) for which $\frac{d}{dx} \{ \arcsin x \} = 2$. Evaluating the derivative:

$$\begin{aligned} y &= \arcsin x \\ 2 &= y' = \frac{1}{\sqrt{1-x^2}} \\ 4 &= \frac{1}{1-x^2} \\ \frac{1}{4} &= 1-x^2 \\ x^2 &= \frac{3}{4} \\ x &= \pm \frac{\sqrt{3}}{2} \\ (x, y) &= \pm \left(\frac{\sqrt{3}}{2}, \frac{\pi}{3} \right) \end{aligned}$$

S-20: We differentiate using the chain rule:

$$\begin{aligned} \frac{d}{dx} \{ \arctan(\csc x) \} &= \frac{1}{1 + \csc^2 x} \cdot \frac{d}{dx} \{ \csc x \} \\ &= \frac{-\csc x \cot x}{1 + \csc^2 x} \\ &= \frac{-\frac{1}{\sin x} \cdot \frac{\cos x}{\sin x}}{1 + \left(\frac{1}{\sin x} \right)^2} \\ &= \frac{-\cos x}{\sin^2 x + 1} \end{aligned}$$

So if $f'(x) = 0$, then $\cos x = 0$, and this happens when $x = \frac{(2n+1)\pi}{2}$ for any integer n . We should check that these points are in the domain of f . Arctangent is defined for all real numbers, so we

only need to check the domain of cosecant; when $x = \frac{(2n+1)\pi}{2}$, then $\sin x = \pm 1 \neq 0$, so $\csc x = \frac{1}{\sin x}$ exists.

S-21: Since $g(y) = f^{-1}(y)$,

$$f(g(y)) = f(f^{-1}(y)) = y$$

Now, we can differentiate with respect to y using the chain rule.

$$\begin{aligned}\frac{d}{dy}\{f(g(y))\} &= \frac{d}{dy}\{y\} \\ f'(g(y)) \cdot g'(y) &= 1 \\ g'(y) &= \frac{1}{f'(g(y))} = \frac{1}{1 - \sin g(y)}\end{aligned}$$

S-22: Write $g(y) = f^{-1}(y)$. Then $g(f(x)) = x$, so differentiating both sides (using the chain rule), we see

$$g'(f(x)) \cdot f'(x) = 1$$

What we want is $g'(\pi - 1)$, so we need to figure out which value of x gives $f(x) = \pi - 1$. A little trial and error leads us to $x = \frac{\pi}{2}$.

$$g'(\pi - 1) \cdot f'\left(\frac{\pi}{2}\right) = 1$$

Since $f'(x) = 2 - \cos(x)$, $f'\left(\frac{\pi}{2}\right) = 2 - 0 = 2$:

$$\begin{aligned}g'(\pi - 1) \cdot 2 &= 1 \\ g'(\pi - 1) &= \frac{1}{2}\end{aligned}$$

S-23: Write $g(y) = f^{-1}(y)$. Then $g(f(x)) = x$, so differentiating both sides (using the chain rule), we see

$$g'(f(x))f'(x) = 1$$

What we want is $g'(e + 1)$, so we need to figure out which value of x gives $f(x) = e + 1$. A little trial and error leads us to $x = 1$.

$$\begin{aligned}g'(f(1))f'(1) &= 1 \\ g'(e + 1) \cdot f'(1) &= 1 \\ g'(e + 1) &= \frac{1}{f'(1)}\end{aligned}$$

It remains only to note that $f'(x) = e^x + 1$, so $f'(1) = e + 1$

$$g'(e + 1) = \frac{1}{e + 1}$$

S-24: We use logarithmic differentiation, our standard method of differentiating an expression of the form (function)^{function}.

$$\begin{aligned} f(x) &= [\sin x + 2]^{\operatorname{arcsec} x} \\ \log(f(x)) &= \operatorname{arcsec} x \cdot \log[\sin x + 2] \\ \frac{f'(x)}{f(x)} &= \frac{1}{|x|\sqrt{x^2 - 1}} \log[\sin x + 2] + \operatorname{arcsec} x \cdot \frac{\cos x}{\sin x + 2} \\ f'(x) &= [\sin x + 2]^{\operatorname{arcsec} x} \left(\frac{\log[\sin x + 2]}{|x|\sqrt{x^2 - 1}} + \frac{\operatorname{arcsec} x \cdot \cos x}{\sin x + 2} \right) \end{aligned}$$

The domain of $\operatorname{arcsec} x$ is $|x| \geq 1$. For any x , $\sin x + 2$ is positive, and a positive number can be raised to any power. (Recall negative numbers cannot be raised to any power—for example, $(-1)^{1/2} = \sqrt{-1}$ is not a real number.) So, the domain of $f(x)$ is $|x| \geq 1$.

S-25: The function $\frac{1}{\sqrt{x^2 - 1}}$ exists only for those values of x with $x^2 - 1 > 0$: that is, the domain of $\frac{1}{\sqrt{x^2 - 1}}$ is $|x| > 1$. However, the domain of arcsine is $|x| \leq 1$. So, there is not one single value of x where $\arcsin x$ and $\frac{1}{\sqrt{x^2 - 1}}$ are both defined.

If the derivative of $\arcsin(x)$ were given by $\frac{1}{\sqrt{x^2 - 1}}$, then the derivative of $\arcsin(x)$ would not exist anywhere, so we would probably just write “derivative does not exist,” instead of making up a function with a mismatched domain. Also, the function $f(x) = \arcsin(x)$ is a smooth curve—its derivative exists at every point strictly inside its domain. (Remember not all curves are like this: for instance, $g(x) = |x|$ does not have a derivative at $x = 0$, but $x = 0$ is strictly inside its domain.) So, it’s a pretty good bet that the derivative of arcsine is *not* $\frac{1}{\sqrt{x^2 - 1}}$.

S-26: This limit represents the derivative computed at $x = 1$ of the function $f(x) = \arctan x$. To see this, simply use the definition of the derivative at $a = 1$:

$$\begin{aligned} \left. \frac{d}{dx} \{f(x)\} \right|_a &= \lim_{x \rightarrow a} \frac{f(x) - f(a)}{x - a} \\ \left. \frac{d}{dx} \{\arctan x\} \right|_1 &= \lim_{x \rightarrow 1} \frac{\arctan x - \arctan 1}{x - 1} \\ &= \lim_{x \rightarrow 1} \frac{\arctan x - \frac{\pi}{4}}{x - 1} \\ &= \lim_{x \rightarrow 1} \left((x - 1)^{-1} \left(\arctan x - \frac{\pi}{4} \right) \right). \end{aligned}$$

Since the derivative of $f(x)$ is $\frac{1}{1+x^2}$, its value at $x = 1$ is exactly $\frac{1}{2}$.

S-27: First, let's interpret the given information: when the input of our function is $2x + 1$ for some x , then its output is $\frac{5x-9}{3x+7}$, for that same x . We're asked to evaluate $f^{-1}(7)$, which is the number y with the property that $f(y) = 7$. If the output of our function is 7, that means

$$7 = \frac{5x-9}{3x+7}$$

and so

$$\begin{aligned}7(3x+7) &= 5x-9 \\ x &= -\frac{29}{8}\end{aligned}$$

So, when $x = -\frac{29}{8}$, our equation $f(2x+1) = \frac{5x-9}{3x+7}$ becomes:

$$f\left(2 \cdot \frac{-29}{8} + 1\right) = \frac{5 \cdot \frac{-29}{8} - 9}{3 \cdot \frac{-29}{8} + 7}$$

Or, equivalently:

$$f\left(-\frac{25}{4}\right) = 7$$

Therefore, $f^{-1}(7) = -\frac{25}{4}$.

S-28: If $f^{-1}(y) = 0$, that means $f(0) = y$. So, we want to find out what we plug into f^{-1} to get 0. Since we only know f^{-1} in terms of a variable x , let's figure out what x gives us an output of 0:

$$\begin{aligned}\frac{2x+3}{x+1} &= 0 \\ 2x+3 &= 0 \\ x &= -\frac{3}{2}\end{aligned}$$

Now, the equation $f^{-1}(4x-1) = \frac{2x+3}{x+1}$ with $x = -\frac{3}{2}$ tells us:

$$f^{-1}\left(4 \cdot \frac{-3}{2} - 1\right) = \frac{2 \cdot \frac{-3}{2} + 3}{\frac{-3}{2} + 1}$$

Or, equivalently:

$$f^{-1}(-7) = 0$$

Therefore, $f(0) = -7$.

S-29:

- Solution 1: We begin by differentiating implicitly. Following the usual convention, we use y' to mean $y'(x)$.

$$\begin{aligned}\arcsin(x+2y) &= x^2 + y^2 && \text{Using the chain rule:} \\ \frac{1+2y'}{\sqrt{1-(x+2y)^2}} &= 2x + 2yy' \\ \frac{1}{\sqrt{1-(x+2y)^2}} + \frac{2y'}{\sqrt{1-(x+2y)^2}} &= 2x + 2yy' \\ \frac{2y'}{\sqrt{1-(x+2y)^2}} - 2yy' &= 2x - \frac{1}{\sqrt{1-(x+2y)^2}} \\ y' \left(\frac{2}{\sqrt{1-(x+2y)^2}} - 2y \right) &= 2x - \frac{1}{\sqrt{1-(x+2y)^2}} \\ y' &= \frac{2x - \frac{1}{\sqrt{1-(x+2y)^2}}}{\frac{2}{\sqrt{1-(x+2y)^2}} - 2y} \left(\frac{\sqrt{1-(x+2y)^2}}{\sqrt{1-(x+2y)^2}} \right) \\ y' &= \frac{2x\sqrt{1-(x+2y)^2} - 1}{2 - 2y\sqrt{1-(x+2y)^2}}\end{aligned}$$

- Solution 2: We begin by taking the sine of both sides of the equation.

$$\begin{aligned}\arcsin(x+2y) &= x^2 + y^2 \\ x+2y &= \sin(x^2 + y^2)\end{aligned}$$

Now, we differentiate implicitly.

$$\begin{aligned}1+2y' &= \cos(x^2 + y^2) \cdot (2x + 2yy') \\ 1+2y' &= 2x\cos(x^2 + y^2) + 2yy'\cos(x^2 + y^2) \\ 2y' - 2yy'\cos(x^2 + y^2) &= 2x\cos(x^2 + y^2) - 1 \\ y'(2 - 2y\cos(x^2 + y^2)) &= 2x\cos(x^2 + y^2) - 1 \\ y' &= \frac{2x\cos(x^2 + y^2) - 1}{2 - 2y\cos(x^2 + y^2)}\end{aligned}$$

- We used two different methods, and got two answers that look pretty different. However, the answers ought to be equivalent. To see this, we remember that for all values of x and y that we care about (those pairs (x, y) in the domain of our curve), the equality

$$\arcsin(x+2y) = x^2 + y^2$$

holds. Drawing a triangle:

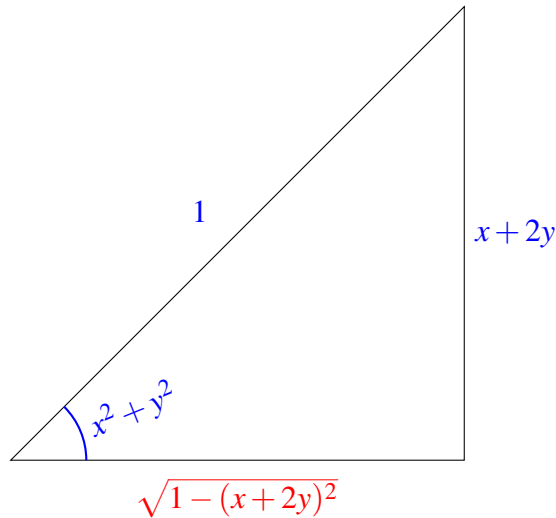

where the adjacent side (in red) come from the Pythagorean Theorem. Then, $\cos(x^2 + y^2) = \sqrt{1 - (x + 2y)^2}$, so using our second solution:

$$\begin{aligned} y' &= \frac{2x \cos(x^2 + y^2) - 1}{2 - 2y \cos(x^2 + y^2)} \\ &= \frac{2x \sqrt{1 - (x + 2y)^2} - 1}{2 - 2y \sqrt{1 - (x + 2y)^2}} \end{aligned}$$

which is exactly the answer from our first solution.

Solutions to Exercises 5 — Jump to [TABLE OF CONTENTS](#)

S-1: We have an equation relating P and Q :

$$P = Q^3$$

We differentiate implicitly with respect to a third variable, t :

$$\frac{dP}{dt} = 3Q^2 \cdot \frac{dQ}{dt}$$

If we know two of the three quantities $\frac{dP}{dt}$, Q , and $\frac{dQ}{dt}$, then we can find the third. Therefore, ii is a question we can solve. If we know P , then we also know Q (it's just the cube root of P), so also we can solve iv. However, if we know neither P nor Q , then we can't find $\frac{dP}{dt}$ based only off $\frac{dQ}{dt}$, and we can't find $\frac{dQ}{dt}$ based only off $\frac{dP}{dt}$. So we can't solve i or iii.

S-2: Suppose that at time t , the point is at $(x(t), y(t))$. Then $x(t)^2 + y(t)^2 = 1$ so that $2x(t)x'(t) + 2y(t)y'(t) = 0$. We are told that at some time t_0 , $x(t_0) = 2/\sqrt{5}$, $y(t_0) = 1/\sqrt{5}$ and

$y'(t_0) = 3$. Then

$$\begin{aligned} 2x(t_0)x'(t_0) + 2y(t_0)y'(t_0) &= 0 && \Rightarrow \\ 2\left(\frac{2}{\sqrt{5}}\right)x'(t) + 2\left(\frac{1}{\sqrt{5}}\right)(3) &= 0 && \Rightarrow \\ x'(t_0) &= -\frac{3}{2} \end{aligned}$$

S-3: The instantaneous percentage rate of change for R is

$$\begin{aligned} 100\frac{R'}{R} &= 100\frac{(PQ)'}{PQ} && R=PQ \\ &= 100\frac{P'Q + PQ'}{PQ} && \text{product rule} \\ &= 100\left[\frac{P'}{P} + \frac{Q'}{Q}\right] && \text{simplify} \\ &= 100[0.08 - 0.02] = 6\% \end{aligned}$$

S-4: (a) By the quotient rule, $F' = \frac{P'Q - PQ'}{Q^2}$. At the moment in question,

$$F' = \frac{5 \times 5 - 25 \times 1}{5^2} = 0.$$

(b) We are told that, at the second moment in time, $P' = 0.1P$ and $Q' = -0.05Q$ (or equivalently $100\frac{P'}{P} = 10$ and $100\frac{Q'}{Q} = -5$). Substituting in these values:

$$\begin{aligned} F' &= \frac{P'Q - PQ'}{Q^2} \\ &= \frac{0.1PQ - P(-0.05Q)}{Q^2} \\ &= \frac{0.15PQ}{Q^2} \\ &= 0.15\frac{P}{Q} \\ &= 0.15F && \Rightarrow \\ F' &= 0.15F \end{aligned}$$

or $100\frac{F'}{F} = 15\%$. That is, the instantaneous percentage rate of change of F is 15%.

S-5:

-
- The distance $z(t)$ between the particles at any moment in time is

$$z^2(t) = x(t)^2 + y(t)^2,$$

where $x(t)$ is the position on the x -axis of the particle A at time t (measured in seconds) and $y(t)$ is the position on the y -axis of the particle B at the same time t .

- We differentiate the above equation with respect to t and get

$$2z \cdot z' = 2x \cdot x' + 2y \cdot y',$$

- We are told that $x' = -2$ and $y' = -3$. (The values are negative because x and y are decreasing.) It will take 3 seconds for particle A to reach $x = 4$, and in this time particle B will reach $y = 3$.
- At this point $z = \sqrt{x^2 + y^2} = \sqrt{3^2 + 4^2} = 5$.
- Hence

$$\begin{aligned} 10z' &= 8 \cdot (-2) + 6 \cdot (-3) = -34 \\ z' &= -\frac{34}{10} = -\frac{17}{5} \text{ units per second.} \end{aligned}$$

S-6:

- We compute the distance $z(t)$ between the two particles after t seconds as

$$z^2(t) = 3^2 + (y_A(t) - y_B(t))^2,$$

where $y_A(t)$ and $y_B(t)$ are the y -coordinates of particles A and B after t seconds, and the horizontal distance between the two particles is always 3 units.

- We are told the distance between the particles is 5 units, this happens when

$$\begin{aligned} (y_A - y_B)^2 &= 5^2 - 3^2 = 16 \\ y_A - y_B &= 4 \end{aligned}$$

That is, when the difference in y -coordinates is 4. This happens when $t = 4$.

- We differentiate the distance equation (from the first bullet point) with respect to t and get

$$2z \cdot z' = 2(y_A' - y_B')(y_A - y_B),$$

- We know that $(y_A - y_B) = 4$, and we are told that $z = 5$, $y_A' = 3$, and $y_B' = 2$. Hence

$$10z'(4) = 2 \times 1 \times 4 = 8$$

- Therefore

$$z'(4) = \frac{8}{10} = \frac{4}{5} \text{ units per second.}$$

S-7:

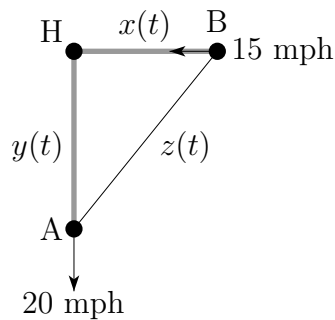

As in the above figure, let $x(t)$ be the distance between H (Hawaii) and ship B, and $y(t)$ be the distance between H and ship A, and $z(t)$ be the distance between ships A and B, all at time t . Then

$$x(t)^2 + y(t)^2 = z(t)^2$$

Differentiating with respect to t ,

$$2x(t)x'(t) + 2y(t)y'(t) = 2z(t)z'(t)$$

$$x(t)x'(t) + y(t)y'(t) = z(t)z'(t)$$

At the specified time, $x(t)$ is decreasing, so $x'(t)$ is negative, and $y(t)$ is increasing, so $y'(t)$ is positive.

$$(300)(-15) + (400)(20) = \sqrt{300^2 + 400^2}z'(t)$$

$$500z'(t) = 3500$$

$$z'(t) = 7 \text{ mph}$$

S-8:

- We compute the distance $d(t)$ between the two snails after t minutes as

$$d^2(t) = 30^2 + (y_1(t) - y_2(t))^2,$$

where $y_1(t)$ is the altitude of the first snail, and $y_2(t)$ the altitude of the second snail after t minutes.

- We differentiate the above equation with respect to t and get

$$2d \cdot d' = 2(y_1' - y_2')(y_1 - y_2)$$

$$d \cdot d' = (y_1' - y_2')(y_1 - y_2)$$

- We are told that $y_1' = 25$ and $y_2' = 15$. It will take 4 minutes for the first snail to reach $y_1 = 100$, and in this time the second snail will reach $y_2 = 60$.
- At this point $d^2 = 30^2 + (100 - 60)^2 = 900 + 1600 = 2500$, hence $d = 50$.

- Therefore

$$50d' = (25 - 15) \times (100 - 60)$$

$$d' = \frac{400}{50} = 8 \text{ cm per minute.}$$

S-9:

- If we write $z(t)$ for the length of the ladder at time t and $y(t)$ for the height of the top end of the ladder at time t we have

$$z(t)^2 = 5^2 + y(t)^2.$$

- We differentiate the above equation with respect to t and get

$$2z \cdot z' = 2y \cdot y',$$

- We are told that $z'(t) = -2$, so $z(3.5) = 20 - 3.5 \cdot 2 = 13$.
- At this point $y = \sqrt{z^2 - 5^2} = \sqrt{169 - 25} = \sqrt{144} = 12$.
- Hence

$$2 \cdot 13 \cdot (-2) = 2 \cdot 12y'$$

$$y' = -\frac{2 \cdot 13}{12} = -\frac{13}{6} \text{ meters per second.}$$

S-10: What we're given is $\frac{dV}{dt}$ (where V is volume of water in the trough, and t is time), and what we are asked for is $\frac{dh}{dt}$ (where h is the height of the water). So, we need an equation relating V and h . First, let's get everything in the same units: centimetres.

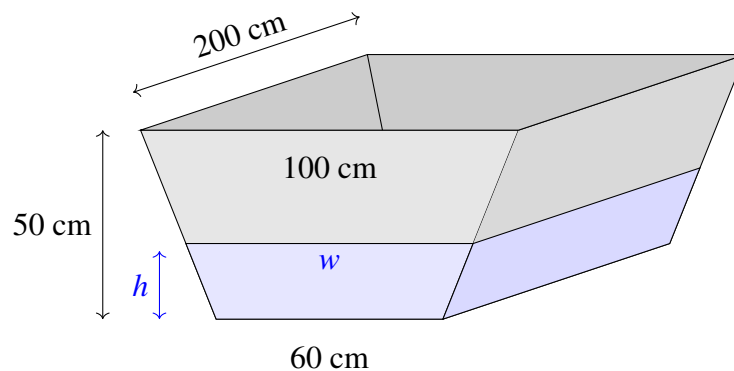

We can calculate the volume of water in the trough by multiplying the area of its trapezoidal cross section by 200 cm. A trapezoid with height h and bases b_1 and b_2 has area $h \left(\frac{b_1 + b_2}{2} \right)$. (To see why this is so, draw the trapezoid as a rectangle flanked by two triangles.) So, using w as the width of the top of the water (as in the diagram above), the area of the cross section of the water in the trough is

$$A = h \left(\frac{60 + w}{2} \right)$$

and therefore the volume of water in the trough is

$$V = 100h(60 + w) \text{ cm}^3.$$

We need a formula for w in terms of h . If we draw lines straight up from the bottom corners of the trapezoid, we break it into rectangles and triangles.

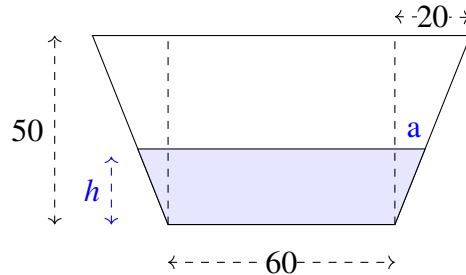

Using similar triangles, $\frac{a}{h} = \frac{20}{50}$, so $a = \frac{2}{5}h$. Then

$$\begin{aligned} w &= 60 + 2a \\ &= 60 + 2\left(\frac{2}{5}h\right) = 60 + \frac{4}{5}h \end{aligned}$$

so

$$\begin{aligned} V &= 100h(60 + w) \\ &= 100h\left(120 + \frac{4}{5}h\right) \\ &= 80h^2 + 12000h \end{aligned}$$

This is the equation we need, relating V and h . Differentiating implicitly with respect to t :

$$\begin{aligned} \frac{dV}{dt} &= 2 \cdot 80h \cdot \frac{dh}{dt} + 12000 \frac{dh}{dt} \\ &= (160h + 12000) \frac{dh}{dt} \end{aligned}$$

We are given that $h = 25$ and $\frac{dV}{dt} = 3$ litres per minute. Converting to cubic centimetres, $\frac{dV}{dt} = -3000$ cubic centimetres per minute. So:

$$\begin{aligned} -3000 &= (160 \cdot 25 + 12000) \frac{dh}{dt} \\ \frac{dh}{dt} &= -\frac{3}{16} = -.1875 \frac{\text{cm}}{\text{min}} \end{aligned}$$

So, the water level is dropping at $\frac{3}{16}$ centimetres per minute.

S-11: If V is the volume of the water in the tank, and t is time, then we are given $\frac{dV}{dt}$. What we want to know is $\frac{dh}{dt}$, where h is the height of the water in the tank. A reasonable plan is to find an equation relating V and h , and differentiate it implicitly with respect to t .

Let's be a little careful about units. The volume of water in the tank is

$$(\text{area of cross section of water}) \times (\text{length of tank})$$

If we measure these values in metres (area in square metres, length in metres), then the volume is going to be in cubic metres. So, when we differentiate with respect to time, our units will be cubic metres per second. The water is flowing in at one litre per second, or 1000 cubic centimetres per second. So, we either have to measure our areas and distances in centimetres, or convert litres to cubic metres. We'll do the latter, but both are fine.

If we imagine one cubic metre as a cube, with each side of length 1 metre, then it's easy to see the volume inside is $(100)^3 = 10^6$ cubic centimetres: it's the volume of a cube with each side of length 100 cm. Since a litre is 10^3 cubic centimetres, and a cubic metre is 10^6 cubic centimetres, one litre is 10^{-3} cubic metres. So, $\frac{dV}{dt} = \frac{1}{10^3}$ cubic metres per second.

Let h be the height of the water (in metres). We can figure out the area of the cross section by breaking it into three pieces: a triangle on the left, a rectangle in the middle, and a trapezoid on the right.

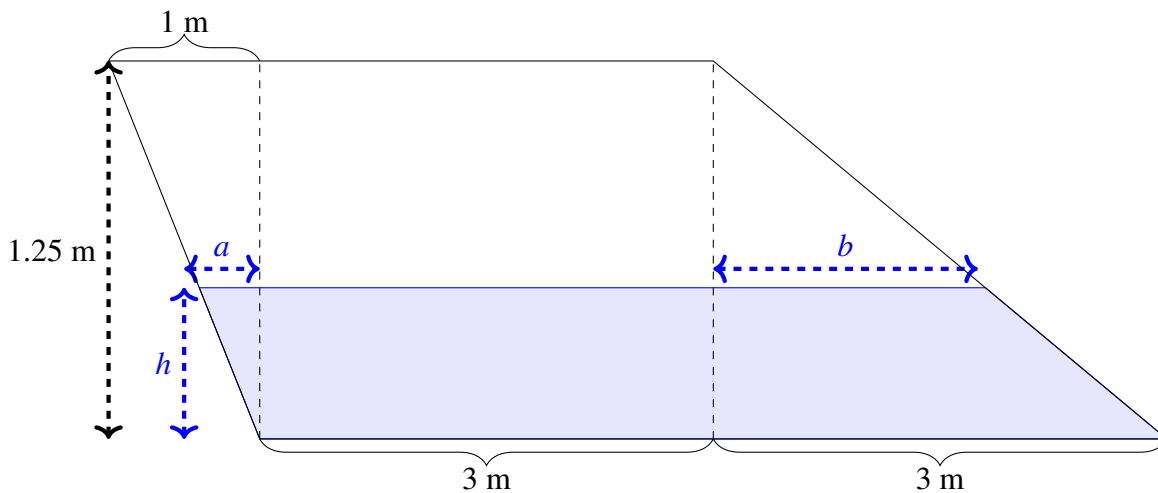

- The triangle on the left has height h metres. Let its base be a metres. It forms a similar triangle with the triangle whose height is 1.25 metres and width is 1 metre, so:

$$\begin{aligned}\frac{a}{h} &= \frac{1}{1.25} \\ a &= \frac{4}{5}h\end{aligned}$$

So, the area of the triangle on the left is

$$\frac{1}{2}ah = \frac{2}{5}h^2$$

- The rectangle in the middle has length 3 metres and height h metres, so its area is $3h$ square metres.

- The trapezoid on the right is a portion of a triangle with base 3 metres and height 1.25 metres. So, its area is

$$\underbrace{\left(\frac{1}{2}(3)(1.25)\right)}_{\text{area of big triangle}} - \underbrace{\left(\frac{1}{2}(b)(1.25-h)\right)}_{\text{area of little triangle}}$$

The little triangle (of base b and height $1.25 - h$) is formed by the *air* on the right side of the tank. It is a similar triangle to the triangle of base 3 and height 1.25, so

$$\frac{b}{1.25-h} = \frac{3}{1.25}$$

$$b = \frac{3}{1.25}(1.25-h)$$

So, the area of the trapezoid on the right is

$$\frac{1}{2}(3)(1.25) - \frac{1}{2}\left(\frac{3}{1.25}\right)(1.25-h)(1.25-h)$$

$$= 3h - \frac{6}{5}h^2$$

So, the area A of the cross section of the water is

$$A = \underbrace{\frac{2}{5}h^2}_{\text{triangle}} + \underbrace{3h}_{\text{rectangle}} + \underbrace{3h - \frac{6}{5}h^2}_{\text{trapezoid}}$$

$$= 6h - \frac{4}{5}h^2$$

So, the volume of water is

$$V = 5\left(6h - \frac{4}{5}h^2\right) = 30h - 4h^2$$

Differentiating with respect to time, t :

$$\frac{dV}{dt} = 30\frac{dh}{dt} - 8h\frac{dh}{dt}$$

When $h = \frac{1}{10}$ metre, and $\frac{dV}{dt} = \frac{1}{10^3}$ cubic metres per second,

$$\frac{1}{10^3} = 30\frac{dh}{dt} - 8\left(\frac{1}{10}\right)\frac{dh}{dt}$$

$$\frac{dh}{dt} = \frac{1}{29200} \text{ metres per second}$$

This is about 1 centimetre every five minutes. You might want a bigger hose.

S-12: Let θ be the angle of your head, where $\theta = 0$ means you are looking straight ahead, and $\theta = \frac{\pi}{2}$ means you are looking straight up. We are interested in $\frac{d\theta}{dt}$, but we only have information about h . So, a reasonable plan is to find an equation relating h and θ , and differentiate with respect to time.

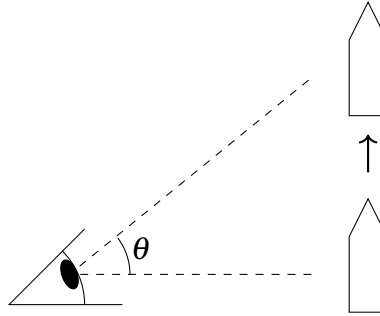

The right triangle formed by you, the rocket, and the rocket's original position has adjacent side (to θ) length 2km, and opposite side (to θ) length $h(t)$ kilometres, so

$$\tan \theta = \frac{h}{2}$$

Differentiating with respect to t :

$$\begin{aligned} \sec^2 \theta \cdot \frac{d\theta}{dt} &= \frac{1}{2} \frac{dh}{dt} \\ \frac{d\theta}{dt} &= \frac{1}{2} \cos^2 \theta \cdot \frac{dh}{dt} \end{aligned}$$

We know $\tan \theta = \frac{h}{2}$. We draw a right triangle with angle θ (filling in the sides using SOH CAH TOA and the Pythagorean theorem) to figure out $\cos \theta$:

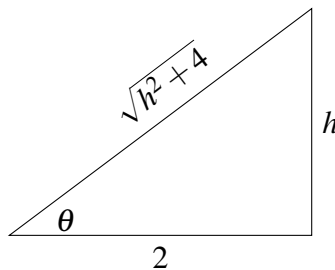

Using the triangle, $\cos \theta = \frac{2}{\sqrt{h^2 + 4}}$, so

$$\begin{aligned} \frac{d\theta}{dt} &= \frac{1}{2} \left(\frac{2}{\sqrt{h^2 + 4}} \right)^2 \cdot \frac{dh}{dt} \\ &= \left(\frac{2}{h^2 + 4} \right) \frac{dh}{dt} \end{aligned}$$

So, the quantities we need to know one minute after liftoff (that is, when $t = \frac{1}{60}$) are $h\left(\frac{1}{60}\right)$ and $\frac{dh}{dt}\left(\frac{1}{60}\right)$. Recall $h(t) = 61750t^2$.

$$h\left(\frac{1}{60}\right) = \frac{61750}{3600} = \frac{1235}{72}$$

$$\frac{dh}{dt} = 2(61750)t$$

$$\frac{dh}{dt}\left(\frac{1}{60}\right) = \frac{2(61750)}{60} = \frac{6175}{3}$$

Returning to the equation $\frac{d\theta}{dt} = \left(\frac{2}{h^2 + 4}\right) \frac{dh}{dt}$:

$$\frac{d\theta}{dt}\left(\frac{1}{60}\right) = \left(\frac{2}{\left(\frac{1235}{72}\right)^2 + 4}\right) \left(\frac{6175}{3}\right) \approx 13.8 \frac{\text{rad}}{\text{hour}} \approx 0.0038 \frac{\text{rad}}{\text{sec}}$$

S-13: (a) Let $x(t)$ be the distance of the train along the track at time t , measured from the point on the track nearest the camera. Let $z(t)$ be the distance from the camera to the train at time t .

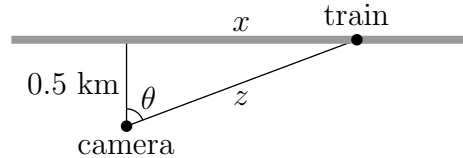

Then $x'(t) = 2$ and at the time in question, $z(t) = 1.3$ km and $x(t) = \sqrt{1.3^2 - 0.5^2} = 1.2$ km. So

$$z(t)^2 = x(t)^2 + 0.5^2$$

$$2z(t)z'(t) = 2x(t)x'(t)$$

$$2 \times 1.3z'(t) = 2 \times 1.2 \times 2$$

$$z'(t) = \frac{2 \times 1.2}{1.3} \approx 1.85 \text{ km/min}$$

(b) Let $\theta(t)$ be the angle shown at time t . Then

$$\sin(\theta(t)) = \frac{x(t)}{z(t)}$$

Differentiating with respect to t :

$$\theta'(t) \cos(\theta(t)) = \frac{x'(t)z(t) - x(t)z'(t)}{z(t)^2}$$

$$\theta'(t) = \frac{x'(t)z(t) - x(t)z'(t)}{z(t)^2 \cos(\theta(t))}$$

From our diagram, we see $\cos(\theta(t)) = \frac{0.5}{z(t)}$, so:

$$= 2 \frac{x'(t)z(t) - x(t)z'(t)}{z(t)}$$

Substituting in $x'(t) = 2$, $z(t) = 1.3$, $x(t) = 1.2$, and $z'(t) = \frac{2 \times 1.2}{1.3}$:

$$\theta'(t) = 2 \frac{2 \times 1.3 - 1.2 \times \frac{2 \times 1.2}{1.3}}{1.3} \approx .592 \text{ radians/min}$$

S-14: Let θ be the angle between the two hands.

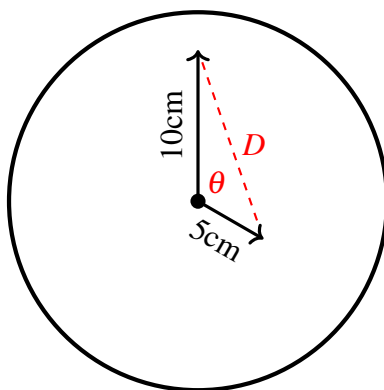

The Law of Cosines tells us that

$$D^2 = 5^2 + 10^2 - 2 \cdot 5 \cdot 10 \cdot \cos \theta$$

$$D^2 = 125 - 100 \cos \theta$$

Differentiating with respect to time t ,

$$2D \frac{dD}{dt} = 100 \sin \theta \cdot \frac{d\theta}{dt}$$

Our tasks now are to find D , θ and $\frac{d\theta}{dt}$ when the time is 4:00. At 4:00, the minute hand is straight up, and the hour hand is $\frac{4}{12} = \frac{1}{3}$ of the way around the clock, so $\theta = \frac{1}{3}(2\pi) = \frac{2\pi}{3}$ at 4:00. Then $D^2 = 125 - 100 \cos\left(\frac{2\pi}{3}\right) = 125 - 100\left(-\frac{1}{2}\right) = 175$, so $D = \sqrt{175} = 5\sqrt{7}$ at 4:00.

To calculate $\frac{d\theta}{dt}$, remember that both hands are moving. The hour hand makes a full rotation every 12 hours, so its rotational speed is $\frac{2\pi}{12} = \frac{\pi}{6}$ radians per hour. The hour hand is being chased by the minute hand. The minute hand makes a full rotation every hour, so its rotational speed is $\frac{2\pi}{1} = 2\pi$ radians per hour. Therefore, the angle θ between the two hands is changing at a rate of

$$\frac{d\theta}{dt} = -\left(2\pi - \frac{\pi}{6}\right) = -\frac{11\pi}{6} \frac{\text{rad}}{\text{hr}}.$$

Now, we plug in D , θ , and $\frac{d\theta}{dt}$ to find $\frac{dD}{dt}$:

$$\begin{aligned}2D \frac{dD}{dt} &= 100 \sin \theta \cdot \frac{d\theta}{dt} \\2(5\sqrt{7}) \frac{dD}{dt} &= 100 \sin\left(\frac{2\pi}{3}\right) \left(\frac{-11\pi}{6}\right) \\10\sqrt{7} \frac{dD}{dt} &= 100 \left(\frac{\sqrt{3}}{2}\right) \left(\frac{-11\pi}{6}\right) = -\frac{275\pi}{\sqrt{3}} \\ \frac{dD}{dt} &= \frac{-55\sqrt{21}\pi}{42} \frac{\text{cm}}{\text{hr}}\end{aligned}$$

So D is decreasing at $\frac{55\sqrt{21}\pi}{42} \approx 19$ centimetres per hour.

S-15: The area at time t is the area of the outer circle minus the area of the inner circle:

$$\begin{aligned}A(t) &= \pi(R(t)^2 - r(t)^2) \\ \text{So, } A'(t) &= 2\pi(R(t)R'(t) - r(t)r'(t))\end{aligned}$$

Plugging in the given data,

$$A' = 2\pi(3 \cdot 2 - 1 \cdot 7) = -2\pi$$

So the area is *shrinking* at a rate of $2\pi \frac{\text{cm}^2}{\text{s}}$.

S-16: The volume between the spheres, while the little one is inside the big one, is

$$V = \frac{4}{3}\pi R^3 - \frac{4}{3}\pi r^3$$

Differentiating implicitly with respect to t :

$$\frac{dV}{dt} = 4\pi R^2 \frac{dR}{dt} - 4\pi r^2 \frac{dr}{dt}$$

We differentiate $R = 10 + 2t$ and $r = 6t$ to find $\frac{dR}{dt} = 2$ and $\frac{dr}{dt} = 6$. When $R = 2r$, $10 + 2t = 2(6t)$, so $t = 1$. When $t = 1$, $R = 12$ and $r = 6$. So:

$$\frac{dV}{dt} = 4\pi(12^2)(2) - 4\pi(6^2)(6) = 288\pi$$

So the volume between the two spheres is increasing at 288π cubic units per unit time.

Remark: when the radius of the inner sphere increases, we are “subtracting” more area. Since the radius of the inner sphere grows faster than the radius of the outer sphere, we might expect the area between the spheres to be decreasing. Although the radius of the outer sphere grows more slowly, a small increase in the radius of the outer sphere results in a larger change in volume than the same increase in the radius of the inner sphere. So, a result showing that the volume between the spheres is increasing is not unreasonable.

S-17: We know something about the rate of change of the height h of the triangle, and we want to know something about the rate of change of its area, A . A reasonable plan is to find an equation relating A and h , and differentiate implicitly with respect to t . The area of a triangle with height h and base b is

$$A = \frac{1}{2}bh$$

Note, b will change with time as well as h . So, differentiating with respect to time, t :

$$\frac{dA}{dt} = \frac{1}{2} \left(\frac{db}{dt} \cdot h + b \cdot \frac{dh}{dt} \right)$$

We are given $\frac{dh}{dt}$ and h , but those b 's are a mystery. We need to relate them to h . We can do this by breaking our triangle into two right triangles and using the Pythagorean Theorem:

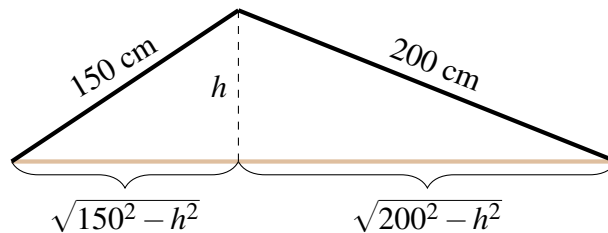

So, the base of the triangle is

$$b = \sqrt{150^2 - h^2} + \sqrt{200^2 - h^2}$$

Differentiating with respect to t :

$$\begin{aligned} \frac{db}{dt} &= \frac{-2h \frac{dh}{dt}}{2\sqrt{150^2 - h^2}} + \frac{-2h \frac{dh}{dt}}{2\sqrt{200^2 - h^2}} \\ &= \frac{-h \frac{dh}{dt}}{\sqrt{150^2 - h^2}} + \frac{-h \frac{dh}{dt}}{\sqrt{200^2 - h^2}} \end{aligned}$$

Using $\frac{dh}{dt} = -3$ centimetres per minute:

$$\frac{db}{dt} = \frac{3h}{\sqrt{150^2 - h^2}} + \frac{3h}{\sqrt{200^2 - h^2}}$$

When $h = 120$, $\sqrt{150^2 - h^2} = 90$ and $\sqrt{200^2 - h^2} = 160$. So, at this moment in time:

$$\begin{aligned} b &= 90 + 160 = 250 \\ \frac{db}{dt} &= \frac{3(120)}{90} + \frac{3(120)}{160} = 4 + \frac{9}{4} = \frac{25}{4} \end{aligned}$$

We return to our equation relating the derivatives of A , b , and h .

$$\frac{dA}{dt} = \frac{1}{2} \left(\frac{db}{dt} \cdot h + b \cdot \frac{dh}{dt} \right)$$

When $h = 120$ cm, $b = 250$, $\frac{dh}{dt} = -3$, and $\frac{db}{dt} = \frac{25}{4}$:

$$\begin{aligned}\frac{dA}{dt} &= \frac{1}{2} \left(\frac{25}{4}(120) + 250(-3) \right) \\ &= 0\end{aligned}$$

Remark: What does it mean that $\left. \frac{dA}{dt} \right|_{h=120} = 0$? Certainly, as the height changes, the area changes as well. As the height sinks to 120 cm, the area is increasing, but after it sinks *past* 120 cm, the area is *decreasing*. So, at the instant when the height is exactly 120 cm, the area is neither increasing nor decreasing: it is at a local maximum. You'll learn more about this kind of problem in Section 8.

S-18: Let S be the flow of salt (in cubic centimetres per second). We want to know $\frac{dS}{dt}$: how fast the flow is changing at time t . We are given an equation for S :

$$S = \frac{1}{5}A$$

where A is the uncovered area of the cut-out. So,

$$\frac{dS}{dt} = \frac{1}{5} \frac{dA}{dt}$$

If we can find $\frac{dA}{dt}$, then we can find $\frac{dS}{dt}$. We are given information about how quickly the door is rotating. If we let θ be the angle made by the leading edge of the door and the far edge of the cut-out (shown below), then $\frac{d\theta}{dt} = -\frac{\pi}{6}$ radians per second. (Since the door is covering more and more of the cut-out, θ is getting smaller, so $\frac{d\theta}{dt}$ is negative.)

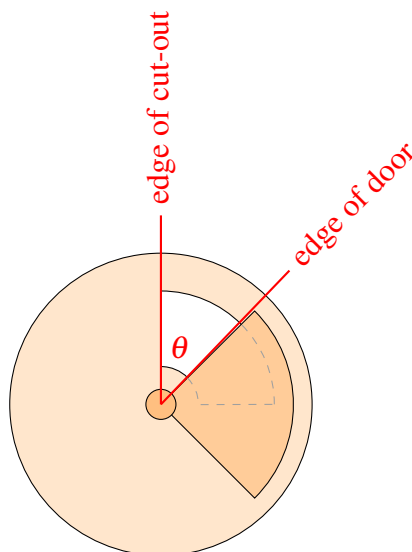

Since we know $\frac{d\theta}{dt}$, and we want to know $\frac{dA}{dt}$ (in order to get $\frac{dS}{dt}$), it is reasonable to look for an equation relating A and θ , and differentiate it implicitly with respect to t to get an equation relating $\frac{dA}{dt}$ and $\frac{d\theta}{dt}$.

The area of an annulus with outer radius 6 cm and inner radius 1 cm is $\pi \cdot 6^2 - \pi \cdot 1^2 = 35\pi$ square centimetres. A sector of that same annulus with angle θ has area $(\frac{\theta}{2\pi})(35\pi)$, since $\frac{\theta}{2\pi}$ is the ratio of the sector to the entire annulus. (For example, if $\theta = \pi$, then the sector is *half* of the entire annulus, so its area is $(1/2)35\pi$.)

So, when $0 \leq \theta \leq \frac{\pi}{2}$, the area of the cutout that is open is

$$A = \frac{\theta}{2\pi}(35\pi) = \frac{35}{2}\theta$$

This is the formula we wanted, relating A and θ . Differentiating with respect to t ,

$$\frac{dA}{dt} = \frac{35}{2} \frac{d\theta}{dt} = \frac{35}{2} \left(-\frac{\pi}{6}\right) = -\frac{35\pi}{12}$$

Since $\frac{dS}{dt} = \frac{1}{5} \frac{dA}{dt}$,

$$\frac{dS}{dt} = -\frac{1}{5} \frac{35\pi}{12} = -\frac{7\pi}{12} \approx -1.8 \frac{\text{cm}^3}{\text{sec}^2}$$

Remark: the change in flow of salt is constant while the door covers more and more of the cut-out, so we never used the fact that precisely half of the cut-out was open. We also never used the radius of the lid, which is immaterial to the flow of salt.

S-19: Let F be the flow of water through the pipe, so $F = \frac{1}{5}A$. We want to know $\frac{dF}{dt}$, so differentiating implicitly with respect to t , we find

$$\frac{dF}{dt} = \frac{1}{5} \frac{dA}{dt}.$$

If we can find $\frac{dA}{dt}$, then we can find $\frac{dF}{dt}$. We know something about the shape of the uncovered area of the pipe; a reasonable plan is to find an equation relating the height of the door with the uncovered area of the pipe. Let h be the distance from the top of the pipe to the bottom of the door, measured in metres.

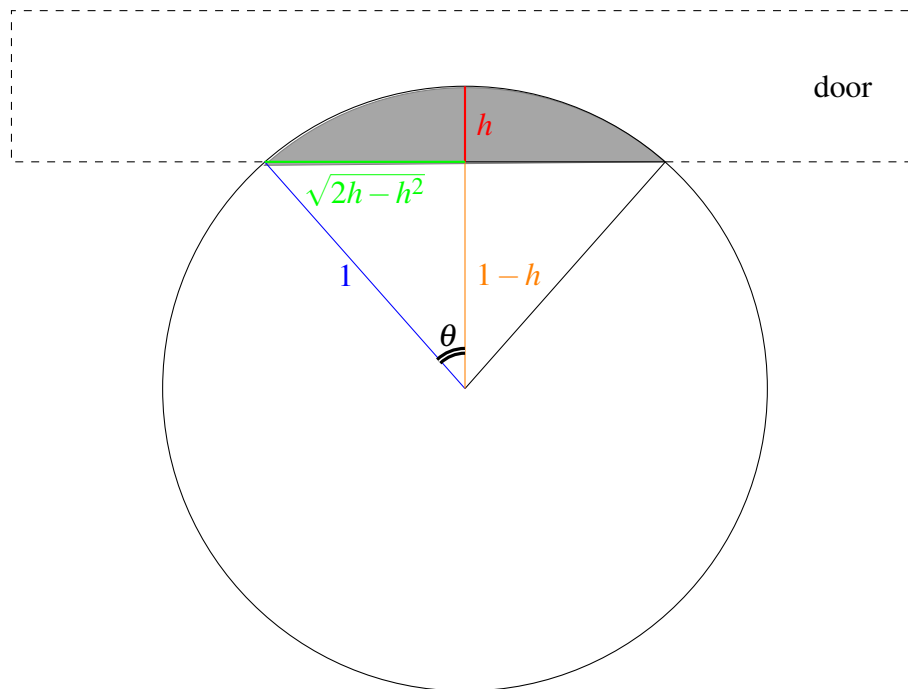

Since the radius of the pipe is 1 metre, the orange line has length $1 - h$ metres, and the blue line has length 1 metre. Using the Pythagorean Theorem, the green line has length $\sqrt{1^2 - (1 - h)^2} = \sqrt{2h - h^2}$ metres.

The uncovered area of the pipe can be broken up into a triangle (of height $1 - h$ and base $2\sqrt{2h - h^2}$) and a sector of a circle (with angle $2\pi - 2\theta$). The area of the triangle is

$$\underbrace{(1 - h)}_{\text{height}} \underbrace{\sqrt{2h - h^2}}_{\frac{1}{2}\text{base}}$$

The area of the sector is

$$\underbrace{\left(\frac{2\pi - 2\theta}{2\pi}\right)}_{\text{fraction of circle}} \underbrace{(\pi \cdot 1^2)}_{\text{area of circle}} = \pi - \theta.$$

Remember: what we want is to find $\frac{dA}{dt}$, and what we know is $\frac{dh}{dt} = 0.01$ metres per second. If we find θ in terms of h , we find A in terms of h , and then differentiate with respect to t .

Since θ is an angle in a right triangle with hypotenuse 1 and adjacent side length $1 - h$, $\cos \theta = \frac{1-h}{1} = 1 - h$. We want to conclude that $\theta = \arccos(1 - h)$, but let's be a little careful: remember that the range of the arccosine function is angles in $[0, \pi]$. We must be confident that $0 \leq \theta \leq \pi$ in order to conclude $\theta = \arccos(1 - h)$ —but clearly, θ is in this range. (Remark: we could also have said $\sin \theta = \frac{\sqrt{2h-h^2}}{1}$, and so $\theta = \arcsin(\sqrt{2h-h^2})$. This would require $-\frac{\pi}{2} \leq \theta \leq \frac{\pi}{2}$, which is true when $h < 1$, but false for $h > 1$. Since our problem asks about $h = 0.25$, we could also use arcsine.)

Now, we know the area of the open pipe in terms of h .

$$\begin{aligned} A &= (\text{area of triangle}) + (\text{area of sector}) \\ &= (1-h)\sqrt{2h-h^2} + (\pi - \theta) \\ &= (1-h)\sqrt{2h-h^2} + \pi - \arccos(1-h) \end{aligned}$$

We want to differentiate with respect to t . Using the chain rule:

$$\begin{aligned} \frac{dA}{dt} &= \frac{dA}{dh} \cdot \frac{dh}{dt} \\ \frac{dA}{dt} &= \left((1-h) \frac{2-2h}{2\sqrt{2h-h^2}} + (-1)\sqrt{2h-h^2} + \frac{-1}{\sqrt{1-(1-h)^2}} \right) \frac{dh}{dt} \\ &= \left(\frac{(1-h)^2}{\sqrt{2h-h^2}} - \sqrt{2h-h^2} - \frac{1}{\sqrt{2h-h^2}} \right) \frac{dh}{dt} \\ &= \left(\frac{(1-h)^2 - 1}{\sqrt{2h-h^2}} - \sqrt{2h-h^2} \right) \frac{dh}{dt} \\ &= \left(\frac{-(2h-h^2)}{\sqrt{2h-h^2}} - \sqrt{2h-h^2} \right) \frac{dh}{dt} \\ &= \left(-\sqrt{2h-h^2} - \sqrt{2h-h^2} \right) \frac{dh}{dt} \\ &= -2\sqrt{2h-h^2} \frac{dh}{dt} \end{aligned}$$

We note here that the negative sign makes sense: as the door lowers, h increases and A decreases, so $\frac{dh}{dt}$ and $\frac{dA}{dt}$ should have opposite signs.

When $h = \frac{1}{4}$ metres, and $\frac{dh}{dt} = \frac{1}{100}$ metres per second:

$$\frac{dA}{dt} = -2\sqrt{\frac{2}{4} - \frac{1}{4^2}} \left(\frac{1}{100} \right) = -\frac{\sqrt{7}}{200} \frac{\text{cm}^2}{\text{s}}$$

Since $\frac{dF}{dt} = \frac{1}{5} \frac{dA}{dt}$:

$$\frac{dF}{dt} = -\frac{\sqrt{7}}{1000} \frac{\text{m}^3}{\text{sec}^2}$$

That is, the flow is decreasing at a rate of $\frac{\sqrt{7}}{1000} \frac{\text{m}^3}{\text{sec}^2}$.

S-20: We are given the rate of change of the volume of liquid, and are asked for the rate of change of the height of the liquid. So, we need an equation relating volume and height.

The volume V of a cone with height h and radius r is $\frac{1}{3}\pi r^2 h$. Since we know $\frac{dV}{dt}$, and want to know $\frac{dh}{dt}$, we need to find a way to deal with the unwanted variable r . We can find r in terms of h by using similar triangles. Viewed from the side, the conical glass is an equilateral triangle, as is the water in it. Using the Pythagorean Theorem, the cone has height $5\sqrt{3}$.

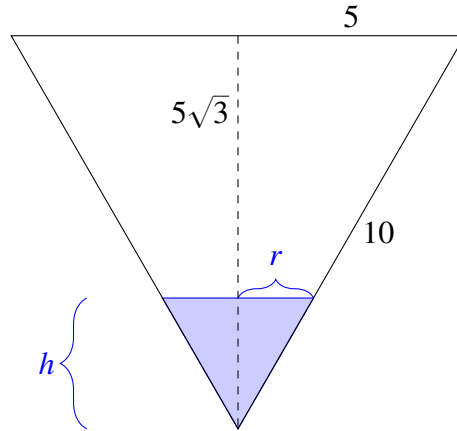

Using similar triangles, $\frac{r}{h} = \frac{5}{5\sqrt{3}}$, so $r = \frac{h}{\sqrt{3}}$. (Remark: we could also use the fact that the water forms a cone that looks like an equilateral triangle when viewed from the side to conclude $r = \frac{h}{\sqrt{3}}$.)

Now, we can write the volume of water in the cone in terms of h , and no other variables.

$$\begin{aligned} V &= \frac{1}{3}\pi r^2 h \\ &= \frac{1}{3}\pi \left(\frac{h}{\sqrt{3}}\right)^2 h \\ &= \frac{\pi}{9}h^3 \end{aligned}$$

Differentiating with respect to t :

$$\frac{dV}{dt} = \frac{\pi}{3}h^2 \frac{dh}{dt}$$

When $h = 7$ cm and $\frac{dV}{dt} = -5$ mL per minute,

$$\begin{aligned} -5 &= \frac{\pi}{3}(49) \frac{dh}{dt} \\ \frac{dh}{dt} &= \frac{-15}{49\pi} \approx -0.097 \text{ cm per minute} \end{aligned}$$

S-21: As is so often the case, we use a right triangle in this problem to relate the quantities.

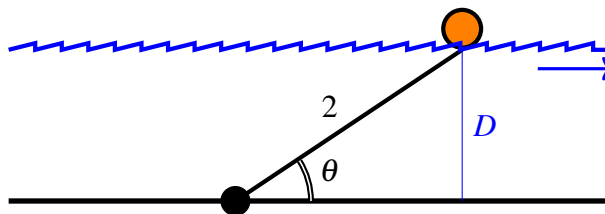

$$\begin{aligned} \sin \theta &= \frac{D}{2} \\ D &= 2 \sin \theta \end{aligned}$$

Using the chain rule, we differentiate both sides with respect to time, t .

$$\frac{dD}{dt} = 2 \cos \theta \cdot \frac{d\theta}{dt}$$

So, if $\frac{d\theta}{dt} = 0.25$ radians per hour and $\theta = \frac{\pi}{4}$ radians, then

$$(a) \quad \frac{dD}{dt} = 2 \cos\left(\frac{\pi}{4}\right) \cdot 0.25 = 2 \left(\frac{1}{\sqrt{2}}\right) \frac{1}{4} = \frac{1}{2\sqrt{2}} \text{ metres per hour.}$$

Setting aside part (b) for a moment, let's think about (c). If $\frac{d\theta}{dt}$ and $\frac{dD}{dt}$ have different signs, then because $\frac{dD}{dt} = 2 \cos \theta \cdot \frac{d\theta}{dt}$, that means $\cos \theta < 0$. We have to have a nonnegative depth, so $D > 0$ and $D = 2 \sin \theta$ implies $\sin \theta > 0$. If $\sin \theta \geq 0$ and $\cos \theta < 0$, then $\theta \in (\pi/2, \pi]$. On the diagram, that looks like this:

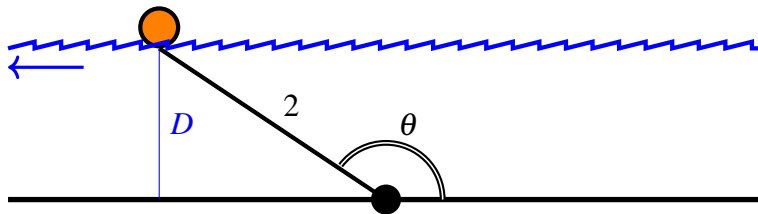

That is: the water has reversed direction. This happens, for instance, when a river empties into the ocean and the tide is high. Skookumchuck Narrows provincial park, in the Sunshine Coast, has reversing rapids.

Now, let's return to (b). If the rope is only 2 metres long, and the river rises *higher* than 2 metres, then our equation $D = 2 \sin \theta$ doesn't work any more: the buoy might be stationary underwater while the water rises or falls (but stays at or above 2 metres deep).

S-22: (a) When the point is at $(0, -2)$, its y -coordinate is not changing, because it is moving along a horizontal line. So, the rate at which the particle moves is simply $\frac{dx}{dt}$. Let θ be the angle an observer would be looking at, in order to watch the point. Since we know $\frac{d\theta}{dt}$, a reasonable plan is to find an equation relating θ and x , and then differentiate implicitly with respect to t . To do this, let's return to our diagram.

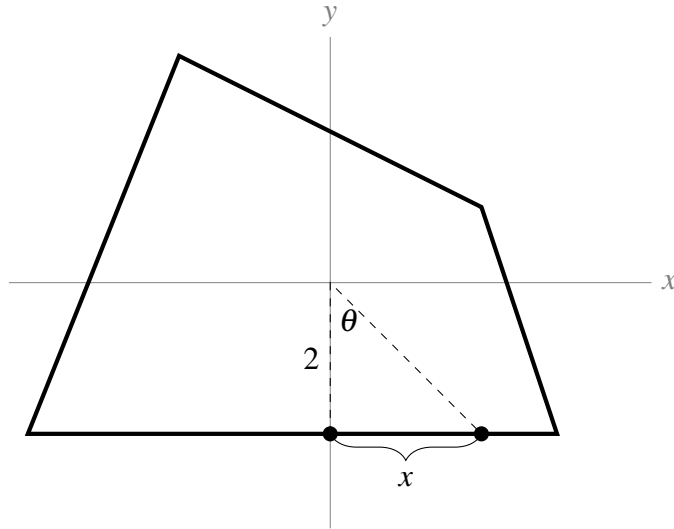

When the point is a little to the right of $(0, -2)$, then we can make a triangle with the origin, as shown. If we let θ be the indicated angle, then $\frac{d\theta}{dt} = 1$ radian per second. (It is given that the observer is turning one radian per second, so this is how fast θ is increasing.) From the right triangle in the diagram, we see

$$\tan \theta = \frac{x}{2}$$

Now, we have to take care of a subtle point. The diagram we drew only makes sense for the point when it is at a position a little to the *right* of $(0, -2)$. So, right now, we've only made a set-up that will find the derivative *from the right*. But, with a little more thought, we see that even when x is negative (that is, when the point is a little to the *left* of $(0, -2)$), our equation holds if we are careful about how we define θ . Let θ be the angle between the line connecting the point and the origin, and the y -axis, where θ is *negative* when the point is to the left of the y -axis.

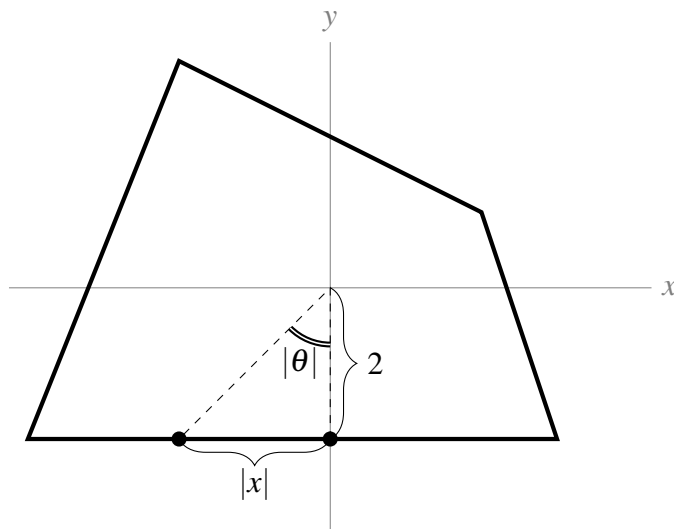

Since x and θ are both negative when the point is to the left of the y -axis,

$$\begin{aligned}\tan|\theta| &= \frac{2}{|x|} \\ \tan(-\theta) &= \frac{-x}{2}\end{aligned}$$

So, since $\tan(-\theta) = -\tan(\theta)$:

$$\tan\theta = \frac{x}{2}$$

So, we've shown that the relationship $\tan\theta = \frac{x}{2}$ holds when our point is at $(x, -2)$, regardless of the sign of x .

Moving on, since we are given $\frac{d\theta}{dt}$ and asked for $\frac{dx}{dt}$, we differentiate with respect to t :

$$\sec^2\theta \cdot \frac{d\theta}{dt} = \frac{1}{2} \cdot \frac{dx}{dt}$$

When the point is at $(0, -2)$, since the observer is turning at one radian per second, also $\frac{d\theta}{dt} = 1$. Also, looking at the diagram, $\theta = 0$. Plugging in these values:

$$\begin{aligned}\sec^2(0) \cdot (1) &= \frac{1}{2} \cdot \frac{dx}{dt} \\ 1 &= \frac{1}{2} \cdot \frac{dx}{dt} \\ \frac{dx}{dt} &= 2\end{aligned}$$

So, the particle is moving at 2 units per second.

(b) When the point is at $(0, 2)$, it is moving along a line with slope $-\frac{1}{2}$ and y -intercept 2. So, it is on the line

$$y = 2 - \frac{1}{2}x$$

That is, at time t , if the point is at $(x(t), y(t))$, then $x(t)$ and $y(t)$ satisfy $y(t) = 2 - \frac{1}{2}x(t)$. Implicitly differentiating with respect to t :

$$\frac{dy}{dt} = -\frac{1}{2} \cdot \frac{dx}{dt}$$

So, when $\frac{dx}{dt} = 1$, $\frac{dy}{dt} = -\frac{1}{2}$. That is, its y -coordinate is decreasing at $\frac{1}{2}$ unit per second.

For the question "How fast is the point moving?", remember that the velocity of an object can be found by differentiating (with respect to *time*) the equation that gives the position of the object. The complicating factors in this case are that (1) the position of our object is not given as a function of time, and (2) the position of our object is given in two dimensions (an x coordinate and a y coordinate), not one.

Remark: the solution below is actually pretty complicated. It is within your abilities to figure it out, but later on in your mathematical career you will learn an easier way, using vectors. For now, take

this as a relatively tough exercise, and a motivation to keep learning: your intuition that *there must be an easier way* is well founded!

The point is moving along a straight line. So, to take care of complication (2), we can give its position as a point on the line. We can take the line as a sort of axis. We'll need to choose a point on the axis to be the "origin": $(2, 1)$ is a convenient point. Let D be the point's (signed) distance along the "axis" from $(2, 1)$. When the point is a distance of one unit to the left of $(2, 1)$, we'll have $D = -1$, and when the point is a distance of one unit to the right of $(2, 1)$, we'll have $D = 1$. Then D changes with respect to time, and $\frac{dD}{dt}$ is the velocity of the point. Since we know $\frac{dx}{dt}$ and $\frac{dy}{dt}$, a reasonable plan is to find an equation relating x , y , and D , and differentiate implicitly with respect to t . (This implicit differentiation takes care of complication (1).) Using the Pythagorean Theorem:

$$D^2 = (x - 2)^2 + (y - 1)^2$$

Differentiating with respect to t :

$$2D \cdot \frac{dD}{dt} = 2(x - 2) \cdot \frac{dx}{dt} + 2(y - 1) \cdot \frac{dy}{dt}$$

We plug in $x = 0$, $y = 2$, $\frac{dx}{dt} = 1$, $\frac{dy}{dt} = -\frac{1}{2}$, and $D = -\sqrt{(0 - 2)^2 + (2 - 1)^2} = -\sqrt{5}$ (negative because the point is to the left of $(2, 1)$):

$$\begin{aligned} -2\sqrt{5} \cdot \frac{dD}{dt} &= 2(-2)(1) + 2(1) \left(-\frac{1}{2}\right) \\ \frac{dD}{dt} &= \frac{\sqrt{5}}{2} \text{ units per second} \end{aligned}$$

S-23: (a) Since the perimeter of the bottle is unchanged (you aren't stretching the plastic), it is always the same as the perimeter before it was smooched, which is the circumference of a circle of radius 5, or $2\pi(5) = 10\pi$. So, using our approximation for the perimeter of an ellipse,

$$\begin{aligned} 10\pi &= \pi \left[3(a + b) - \sqrt{(a + 3b)(3a + b)} \right] \\ 10 &= 3(a + b) - \sqrt{(a + 3b)(3a + b)} \end{aligned}$$

(b) The area of the base of the bottle is πab , and its height is 20 cm, so the volume of the bottle is

$$V = 20\pi ab$$

(c) As you smooch the bottle, its volume decreases, so the water spills out. (If it turns out that the volume is increasing, then no water is spilling out—but life experience suggests, and our calculations verify, that this is not the case.) The water will spill out at a rate of $-\frac{dV}{dt}$ cubic centimetres per second, where V is the volume inside the bottle. We know something about a and $\frac{da}{dt}$, so a reasonable plan is to differentiate the equation from (b) (relating V and a) with respect to t .

Using the product rule, we differentiate the equation in (b) implicitly with respect to t and get

$$\frac{dV}{dt} = 20\pi \left(\frac{da}{dt}b + a \frac{db}{dt} \right)$$

So, we need to find the values of a , b , $\frac{da}{dt}$, and $\frac{db}{dt}$ at the moment when $a = 2b$.

The equation from (a) tells us $10 = 3(a + b) - \sqrt{(a + 3b)(3a + b)}$. So, when $a = 2b$,

$$\begin{aligned} 10 &= 3(2b + b) - \sqrt{(2b + 3b)(6b + b)} \\ 10 &= 9b - \sqrt{(5b)(7b)} = b(9 - \sqrt{35}) \\ b &= \frac{10}{9 - \sqrt{35}} \end{aligned}$$

where we use the fact that b is a positive number, so $\sqrt{b^2} = |b| = b$.

Since $a = 2b$,

$$a = \frac{20}{9 - \sqrt{35}}$$

Now we know a and b at the moment when $a = 2b$. We still need to know $\frac{da}{dt}$ and $\frac{db}{dt}$ at that moment. Since $a = 5 + t$, always $\frac{da}{dt} = 1$. The equation from (a) relates a and b , so differentiating both sides with respect to t will give us an equation relating $\frac{da}{dt}$ and $\frac{db}{dt}$. When differentiating the portion with a square root, be careful not to forget the chain rule.

$$0 = 3 \left(\frac{da}{dt} + \frac{db}{dt} \right) - \frac{\left(\frac{da}{dt} + 3 \frac{db}{dt} \right) (3a + b) + (a + 3b) \left(3 \frac{da}{dt} + \frac{db}{dt} \right)}{2\sqrt{(a + 3b)(3a + b)}}$$

Since $\frac{da}{dt} = 1$:

$$0 = 3 \left(1 + \frac{db}{dt} \right) - \frac{\left(1 + 3 \frac{db}{dt} \right) (3a + b) + (a + 3b) \left(3 + \frac{db}{dt} \right)}{2\sqrt{(a + 3b)(3a + b)}}$$

At this point, we could plug in the values we know for a and b at the moment when $a = 2b$. However, the algebra goes a little smoother if we start by plugging in $a = 2b$:

$$\begin{aligned}
 0 &= 3 \left(1 + \frac{db}{dt} \right) - \frac{(1 + 3\frac{db}{dt})(7b) + (5b)(3 + \frac{db}{dt})}{2\sqrt{(5b)(7b)}} \\
 0 &= 3 \left(1 + \frac{db}{dt} \right) - \frac{b(7 + 21\frac{db}{dt} + 15 + 5\frac{db}{dt})}{2b\sqrt{35}} \\
 0 &= 3 \left(1 + \frac{db}{dt} \right) - \frac{22 + 26\frac{db}{dt}}{2\sqrt{35}} \\
 0 &= 3 + 3\frac{db}{dt} - \frac{11}{\sqrt{35}} - \frac{13}{\sqrt{35}} \frac{db}{dt} \\
 -3 + \frac{11}{\sqrt{35}} &= \left(3 - \frac{13}{\sqrt{35}} \right) \frac{db}{dt} \\
 \frac{db}{dt} &= \frac{-3 + \frac{11}{\sqrt{35}}}{3 - \frac{13}{\sqrt{35}}} = \frac{-3\sqrt{35} + 11}{3\sqrt{35} - 13}
 \end{aligned}$$

Now, we can calculate $\frac{dV}{dt}$ at the moment when $a = 2b$. We already found

$$\frac{dV}{dt} = 20\pi \left(\frac{da}{dt}b + a\frac{db}{dt} \right)$$

So, plugging in the values of a , b , $\frac{da}{dt}$, and $\frac{db}{dt}$ at the moment when $a = 2b$:

$$\begin{aligned}
 \frac{dV}{dt} &= 20\pi \left((1) \left(\frac{10}{9 - \sqrt{35}} \right) + \left(\frac{20}{9 - \sqrt{35}} \right) \left(\frac{-3\sqrt{35} + 11}{3\sqrt{35} - 13} \right) \right) \\
 &= \frac{200\pi}{9 - \sqrt{35}} \left(1 - 2 \left(\frac{3\sqrt{35} - 11}{3\sqrt{35} - 13} \right) \right) \\
 &\approx -375.4 \frac{\text{cm}^3}{\text{sec}}
 \end{aligned}$$

So the water is spilling out of the cup at about 375.4 cubic centimetres per second.

Remark: the algebra in this problem got a little nasty, but the method behind its solution is no more difficult than most of the problems in this section. One of the reasons why calculus is so widely taught in universities is to give you lots of practice with problem-solving: taking a big problem, breaking it into pieces you can manage, solving the pieces, and getting a solution.

A problem like this can sometimes derail people. Breaking it up into pieces isn't so hard, but when you actually do those pieces, you can get confused and forget why you are doing the calculations you're doing. If you find yourself in this situation, look back a few steps to remind yourself why you started the calculation you just did. It can also be helpful to write notes, like "We are trying to find $\frac{dV}{dt}$. We already know that $\frac{dV}{dt} = \dots$. We still need to find a , b , $\frac{da}{dt}$ and $\frac{db}{dt}$."

S-24: Since $A = 0$, the equation relating the variables tells us:

$$\begin{aligned}0 &= \log(C^2 + D^2 + 1) \\1 &= C^2 + D^2 + 1 \\0 &= C^2 + D^2 \\0 &= C = D\end{aligned}$$

This will probably be useful information. Since we're also given the value of a derivative, let's differentiate the equation relating the variables implicitly with respect to t . For ease of notation, we will write $\frac{dA}{dt} = A'$, etc.

$$A'B + AB' = \frac{2CC' + 2DD'}{C^2 + D^2 + 1}$$

At $t = 10$, $A = C = D = 0$:

$$\begin{aligned}A'B + 0 &= \frac{0 + 0}{0 + 0 + 1} \\A'B &= 0\end{aligned}$$

at $t = 10$, $A' = 2$ units per second:

$$\begin{aligned}2B &= 0 \\B &= 0.\end{aligned}$$

Solutions to Exercises 6 — Jump to [TABLE OF CONTENTS](#)

S-1: There are many possible answers. Consider these: $f(x) = 5x$, $g(x) = 2x$. Then

$$\lim_{x \rightarrow \infty} f(x) = \lim_{x \rightarrow \infty} g(x) = \infty, \text{ and } \lim_{x \rightarrow \infty} \frac{f(x)}{g(x)} = \lim_{x \rightarrow \infty} \frac{5x}{2x} = \lim_{x \rightarrow \infty} \frac{5}{2} = \frac{5}{2} = 2.5.$$

S-2: There are many possible answers. Consider these: $f(x) = x$, $g(x) = x^2$. Then

$$\lim_{x \rightarrow \infty} f(x) = \lim_{x \rightarrow \infty} g(x) = \infty, \text{ and } \lim_{x \rightarrow \infty} \frac{f(x)}{g(x)} = \lim_{x \rightarrow \infty} \frac{x}{x^2} = \lim_{x \rightarrow \infty} \frac{1}{x} = 0.$$

S-3: If we plug in $x = 1$ to the numerator and the denominator, we find they are both zero. So, we have an indeterminate form appropriate for L'Hôpital's Rule.

$$\lim_{x \rightarrow 1} \underbrace{\frac{x^3 - e^{x-1}}{\sin(\pi x)}}_{\substack{\text{num} \rightarrow 0 \\ \text{den} \rightarrow 0}} = \lim_{x \rightarrow 1} \frac{3x^2 - e^{x-1}}{\pi \cos(\pi x)} = -\frac{2}{\pi}$$

S-4: Be careful– this is not an indeterminate form!

As $x \rightarrow 0+$, the numerator $\log x \rightarrow -\infty$. That is, the numerator is becoming an increasingly huge, negative number. As $x \rightarrow 0+$, the denominator $x \rightarrow 0+$, which only serves to make the total fraction even larger, and still negative. So, $\lim_{x \rightarrow 0^+} \frac{\log x}{x} = -\infty$.

Remark: if we had tried to use l'Hôpital's Rule here, we would have come up with the wrong answer. If we differentiate the numerator and the denominator, the fraction becomes $\frac{\frac{1}{x}}{1} = \frac{1}{x}$, and $\lim_{x \rightarrow 0^+} \frac{1}{x} = \infty$. The reason we cannot apply l'Hôpital's Rule is that we do not have an indeterminate form, like both numerator and denominator going to infinity, or both numerator and denominator going to zero.

S-5: We rearrange the expression to a more natural form:

$$\lim_{x \rightarrow \infty} (\log x)^2 e^{-x} = \lim_{x \rightarrow \infty} \underbrace{\frac{(\log x)^2}{e^x}}_{\substack{\text{num} \rightarrow \infty \\ \text{den} \rightarrow \infty}}$$

Both the numerator and denominator go to infinity as x goes to infinity. So, we can apply l'Hôpital's Rule. In fact, we end up applying it twice.

$$\begin{aligned} &= \lim_{x \rightarrow \infty} \underbrace{\frac{2 \log x}{x e^x}}_{\substack{\text{num} \rightarrow \infty \\ \text{den} \rightarrow \infty}} \\ &= \lim_{x \rightarrow \infty} \frac{2/x}{x e^x + e^x} \end{aligned}$$

The numerator gets smaller and smaller while the denominator gets larger and larger, so:

$$= 0$$

S-6:

$$\lim_{x \rightarrow \infty} x^2 e^{-x} = \lim_{x \rightarrow \infty} \underbrace{\frac{x^2}{e^x}}_{\substack{\text{num} \rightarrow \infty \\ \text{den} \rightarrow \infty}} = \lim_{x \rightarrow \infty} \underbrace{\frac{2x}{e^x}}_{\substack{\text{num} \rightarrow \infty \\ \text{den} \rightarrow \infty}} = \lim_{x \rightarrow \infty} \underbrace{\frac{2}{e^x}}_{\substack{\text{num} \rightarrow \infty \\ \text{den} \rightarrow \infty}} = 0$$

S-7:

$$\begin{aligned} \lim_{x \rightarrow 0} \underbrace{\frac{x - x \cos x}{x - \sin x}}_{\substack{\text{num} \rightarrow 0 \\ \text{den} \rightarrow 0}} &= \lim_{x \rightarrow 0} \underbrace{\frac{1 - \cos x + x \sin x}{1 - \cos x}}_{\substack{\text{num} \rightarrow 0 \\ \text{den} \rightarrow 0}} = \lim_{x \rightarrow 0} \underbrace{\frac{\sin x + \sin x + x \cos x}{\sin x}}_{\substack{\text{num} \rightarrow 0 \\ \text{den} \rightarrow 0}} \\ &= \lim_{x \rightarrow 0} \frac{2 \cos x + \cos x - x \sin x}{\cos x} = 3 \end{aligned}$$

S-8: If we plug in $x = 0$ to the numerator and denominator, both are zero, so this is a candidate for l'Hôpital's Rule. However, an easier way to evaluate the limit is to factor x^2 from the numerator and denominator, and cancel.

$$\begin{aligned} \lim_{x \rightarrow 0} \frac{\sqrt{x^6 + 4x^4}}{x^2 \cos x} &= \lim_{x \rightarrow 0} \frac{\sqrt{x^4} \sqrt{x^2 + 4}}{x^2 \cos x} \\ &= \lim_{x \rightarrow 0} \frac{x^2 \sqrt{x^2 + 4}}{x^2 \cos x} \\ &= \lim_{x \rightarrow 0} \frac{\sqrt{x^2 + 4}}{\cos x} \\ &= \frac{\sqrt{0^2 + 4}}{\cos(0)} = 2 \end{aligned}$$

S-9:

$$\lim_{x \rightarrow \infty} \underbrace{\frac{(\log x)^2}{x}}_{\substack{\text{num} \rightarrow \infty \\ \text{den} \rightarrow \infty}} = \lim_{x \rightarrow \infty} \frac{2(\log x) \frac{1}{x}}{1} = 2 \lim_{x \rightarrow \infty} \underbrace{\frac{\log x}{x}}_{\substack{\text{num} \rightarrow \infty \\ \text{den} \rightarrow \infty}} = 2 \lim_{x \rightarrow \infty} \frac{\frac{1}{x}}{1} = 0$$

S-10:

$$\lim_{x \rightarrow 0} \underbrace{\frac{1 - \cos x}{\sin^2 x}}_{\substack{\text{num} \rightarrow 0 \\ \text{den} \rightarrow 0}} = \lim_{x \rightarrow 0} \frac{\sin x}{2 \sin x \cos x} = \lim_{x \rightarrow 0} \frac{1}{2 \cos x} = \frac{1}{2}$$

S-11: If we plug in $x = 0$, the numerator is zero, and the denominator is

$$\sec 0 = \frac{1}{\cos 0} = \frac{1}{1} = 1. \text{ So the limit is } \frac{0}{1} = 0.$$

Be careful: you cannot use l'Hôpital's Rule here, because the fraction does not give an indeterminate form. If you try to differentiate the numerator and the denominator, you get an expression whose limit does not exist:

$$\lim_{x \rightarrow 0} \frac{1}{\sec x \tan x} = \lim_{x \rightarrow 0} \cos x \cdot \frac{\cos x}{\sin x} = DNE.$$

S-12: If we plug $x = 0$ into the denominator, we get 1. However, the numerator is an indeterminate form: $\tan 0 = 0$, while $\lim_{x \rightarrow 0^+} \csc x = \infty$ and $\lim_{x \rightarrow 0^-} \csc x = -\infty$. If we use $\csc x = \frac{1}{\sin x}$, our expression becomes

$$\lim_{x \rightarrow 0} \frac{\tan x \cdot (x^2 + 5)}{\sin x \cdot e^x}$$

Since plugging in $x = 0$ makes both the numerator and the denominator equal to zero, this is a candidate for l'Hôpital's Rule. However, a much easier way is to simplify the trig first.

$$\begin{aligned}\lim_{x \rightarrow 0} \frac{\tan x \cdot (x^2 + 5)}{\sin x \cdot e^x} &= \lim_{x \rightarrow 0} \frac{\sin x \cdot (x^2 + 5)}{\cos x \cdot \sin x \cdot e^x} \\ &= \lim_{x \rightarrow 0} \frac{x^2 + 5}{\cos x \cdot e^x} \\ &= \frac{0^2 + 5}{\cos(0) \cdot e^0} = 5\end{aligned}$$

S-13: If we plug in $x = 0$, both numerator and denominator become zero. So, we have exactly one of the indeterminate forms that l'Hôpital's Rule applies to.

$$\lim_{x \rightarrow 0} \underbrace{\frac{\sin(x^3 + 3x^2)}{\sin^2 x}}_{\substack{\text{num} \rightarrow 0 \\ \text{den} \rightarrow 0}} = \lim_{x \rightarrow 0} \frac{(3x^2 + 6x) \cos(x^3 + 3x^2)}{2 \sin x \cos x}$$

If we plug in $x = 0$, still we find that both the numerator and the denominator go to zero. We could jump in with another iteration of l'Hôpital's Rule. However, the derivatives would be a little messy, so we use limit laws and break up the fraction into the product of two fractions. If both limits exist:

$$\lim_{x \rightarrow 0} \frac{(3x^2 + 6x) \cos(x^3 + 3x^2)}{2 \sin x \cos x} = \left(\lim_{x \rightarrow 0} \frac{x^2 + 2x}{\sin x} \right) \cdot \left(\lim_{x \rightarrow 0} \frac{3 \cos(x^3 + 3x^2)}{2 \cos x} \right)$$

We can evaluate the right-hand limit by simply plugging in $x = 0$:

$$\begin{aligned}&= \frac{3}{2} \lim_{x \rightarrow 0} \underbrace{\frac{x^2 + 2x}{\sin x}}_{\substack{\text{num} \rightarrow 0 \\ \text{den} \rightarrow 0}} \\ &= \frac{3}{2} \lim_{x \rightarrow 0} \frac{2x + 2}{\cos x} \\ &= \frac{3}{2} \left(\frac{2}{1} \right) = 3\end{aligned}$$

S-14:

$$\lim_{x \rightarrow 1} \frac{\log(x^3)}{x^2 - 1} = \lim_{x \rightarrow 1} \underbrace{\frac{3 \log(x)}{x^2 - 1}}_{\substack{\text{num} \rightarrow 0 \\ \text{den} \rightarrow 0}} = \lim_{x \rightarrow 1} \frac{3/x}{2x} = \frac{3}{2}$$

S-15:

• Solution 1.

$$\lim_{x \rightarrow 0} \frac{e^{-1/x^2}}{x^4} = \lim_{x \rightarrow 0} \underbrace{\frac{\frac{1}{x^4}}{e^{1/x^2}}}_{\substack{\text{num} \rightarrow \infty \\ \text{den} \rightarrow \infty}} = \lim_{x \rightarrow 0} \frac{\frac{-4}{x^5}}{\frac{-2}{x^3} e^{1/x^2}} = \lim_{x \rightarrow 0} \underbrace{\frac{\frac{2}{x^2}}{e^{1/x^2}}}_{\substack{\text{num} \rightarrow \infty \\ \text{den} \rightarrow \infty}} = \lim_{x \rightarrow 0} \frac{\frac{-4}{x^3}}{\frac{-2}{x^3} e^{1/x^2}} = \lim_{x \rightarrow 0} \frac{2}{e^{1/x^2}} = 0$$

since, as $x \rightarrow 0$, the exponent $\frac{1}{x^2} \rightarrow \infty$ so that $e^{1/x^2} \rightarrow \infty$ and $e^{-1/x^2} \rightarrow 0$.

• Solution 2.

$$\lim_{x \rightarrow 0} \frac{e^{-1/x^2}}{x^4} = \lim_{t = \frac{1}{x^2} \rightarrow \infty} \frac{e^{-t}}{t^{-2}} = \lim_{t \rightarrow \infty} \underbrace{\frac{t^2}{e^t}}_{\substack{\text{num} \rightarrow \infty \\ \text{den} \rightarrow \infty}} = \lim_{t \rightarrow \infty} \underbrace{\frac{2t}{e^t}}_{\substack{\text{num} \rightarrow \infty \\ \text{den} \rightarrow \infty}} = \lim_{t \rightarrow \infty} \frac{2}{e^t} = 0$$

S-16:

$$\lim_{x \rightarrow 0} \underbrace{\frac{xe^x}{\tan(3x)}}_{\substack{\text{num} \rightarrow 0 \\ \text{den} \rightarrow 0}} = \lim_{x \rightarrow 0} \frac{e^x + xe^x}{3 \sec^2(3x)} = \frac{1}{3}$$

S-17: Both the numerator and denominator converge to 0 as $x \rightarrow 0$. So, by l'Hôpital,

$$\lim_{x \rightarrow 0} \underbrace{\frac{1 + cx - \cos x}{e^{x^2} - 1}}_{\substack{\text{num} \rightarrow 0 \\ \text{den} \rightarrow 0}} = \lim_{x \rightarrow 0} \frac{c + \sin x}{2xe^{x^2}}$$

The new denominator still converges to 0 as $x \rightarrow 0$. For the limit to exist, the same must be true for the new numerator. This tells us that if $c \neq 0$, the limit does not exist. We should check whether the limit exists when $c = 0$. Using l'Hôpital:

$$\lim_{x \rightarrow 0} \underbrace{\frac{\sin x}{2xe^{x^2}}}_{\substack{\text{num} \rightarrow 0 \\ \text{den} \rightarrow 0}} = \lim_{x \rightarrow 0} \frac{\cos x}{e^{x^2}(4x^2 + 2)} = \frac{1}{1(0 + 2)} = \frac{1}{2}.$$

So, the limit exists when $c = 0$.

S-18: The first thing we notice is, regardless of k , when we plug in $x = 0$ both numerator and denominator become zero. Let's use this fact, and apply l'Hôpital's Rule.

$$\begin{aligned} \lim_{x \rightarrow 0} \underbrace{\frac{e^{k \sin(x^2)} - (1 + 2x^2)}{x^4}}_{\substack{\text{num} \rightarrow 0 \\ \text{den} \rightarrow 0}} &= \lim_{x \rightarrow 0} \frac{2kx \cos(x^2) e^{k \sin(x^2)} - 4x}{4x^3} \\ &= \lim_{x \rightarrow 0} \frac{2k \cos(x^2) e^{k \sin(x^2)} - 4}{4x^2} \end{aligned}$$

When we plug in $x = 0$, the denominator becomes 0, and the numerator becomes $2k - 4$. So, we'll need some cases, because the behaviour of the limit depends on k .

For $k = 2$:

$$\begin{aligned} \lim_{x \rightarrow 0} \frac{2k \cos(x^2) e^{k \sin(x^2)} - 4}{4x^2} &= \lim_{x \rightarrow 0} \underbrace{\frac{4 \cos(x^2) e^{2 \sin(x^2)} - 4}{4x^2}}_{\substack{\text{num} \rightarrow 0 \\ \text{den} \rightarrow 0}} \\ &= \lim_{x \rightarrow 0} \frac{-8x \sin(x^2) e^{2 \sin(x^2)} + 16x \cos^2(x^2) e^{2 \sin(x^2)}}{8x} \\ &= \lim_{x \rightarrow 0} [-\sin(x^2) e^{2 \sin(x^2)} + 2 \cos^2(x^2) e^{2 \sin(x^2)}] \\ &= 2 \end{aligned}$$

For $k > 2$, the numerator goes to $2k - 4$, which is a positive constant, while the denominator goes to 0 from the right, so:

$$\lim_{x \rightarrow 0} \frac{2k \cos(x^2) e^{k \sin(x^2)} - 4}{4x^2} = \infty$$

For $k < 2$, the numerator goes to $2k - 4$, which is a negative constant, while the denominator goes to 0 from the right, so:

$$\lim_{x \rightarrow 0} \frac{2k \cos(x^2) e^{k \sin(x^2)} - 4}{4x^2} = -\infty$$

S-19:

- We want to find the limit as n goes to infinity of the percentage error, $\lim_{n \rightarrow \infty} 100 \frac{|S(n) - A(n)|}{|S(n)|}$.

Since $A(n)$ is a nicer function than $S(n)$, let's simplify:

$$\lim_{n \rightarrow \infty} 100 \frac{|S(n) - A(n)|}{|S(n)|} = 100 \left| 1 - \lim_{n \rightarrow \infty} \frac{A(n)}{S(n)} \right|.$$

We figure out this limit the natural way:

$$\begin{aligned} 100 \left| 1 - \lim_{n \rightarrow \infty} \frac{A(n)}{S(n)} \right| &= 100 \left| 1 - \lim_{n \rightarrow \infty} \frac{5n^4}{\underbrace{5n^4 - 13n^3 - 4n + \log(n)}_{\substack{\text{num} \rightarrow \infty \\ \text{den} \rightarrow \infty}}} \right| \\ &= 100 \left| 1 - \lim_{n \rightarrow \infty} \frac{20n^3}{20n^3 - 39n^2 - 4 + \frac{1}{n}} \right| \\ &= 100 \left| 1 - \lim_{n \rightarrow \infty} \frac{n^3}{n^3} \cdot \frac{20}{20 - \frac{39}{n} - \frac{4}{n^3} + \frac{1}{n^4}} \right| \\ &= 100 |1 - 1| = 0 \end{aligned}$$

So, as n gets larger and larger, the relative error in the approximation gets closer and closer to 0.

- Now, let's look at the absolute error.

$$\lim_{n \rightarrow \infty} |S(n) - A(n)| = \lim_{n \rightarrow \infty} |-13n^3 - 4n + \log n| = \infty$$

So although the error gets small *relative to the giant numbers we're talking about*, the absolute error grows without bound.

S-20: From Example 6.3.4, we know that $\lim_{x \rightarrow 0} (1+x)^{\frac{a}{x}} = e^a$, so $\lim_{x \rightarrow 0} (1+x)^{\frac{\log 5}{x}} = e^{\log 5} = 5$.

However, this is the limit as x goes to 0, which is not what we were asked. So, we modify the functions by replacing x with $\frac{1}{x}$. If $x \rightarrow 0^+$, then $\frac{1}{x} \rightarrow \infty$.

Taking $f(x) = 1 + \frac{1}{x}$ and $g(x) = x \log 5$, we see:

(i) $\lim_{x \rightarrow \infty} f(x) = \lim_{x \rightarrow \infty} \left(1 + \frac{1}{x}\right) = 1$

(ii) $\lim_{x \rightarrow \infty} g(x) = \lim_{x \rightarrow \infty} x \log 5 = \infty$

(iii) Let us name $\frac{1}{x} = X$. Then as $x \rightarrow \infty$, $X \rightarrow 0^+$, so:

$$\lim_{x \rightarrow \infty} [f(x)]^{g(x)} = \lim_{x \rightarrow \infty} \left[1 + \frac{1}{x}\right]^{x \log 5} = \lim_{x \rightarrow \infty} \left[1 + \frac{1}{x}\right]^{\frac{\log 5}{\frac{1}{x}}} = \lim_{X \rightarrow 0^+} [1 + X]^{\frac{\log 5}{X}} = e^{\log 5} = 5, \text{ where in the penultimate step, we used the result of Example 6.3.4.}$$

S-21: $\lim_{x \rightarrow 0} \sin^2 x = 0$, and $\lim_{x \rightarrow 0} \frac{1}{x^2} = \infty$, so we have the form 0^∞ . (Note that $\sin^2 x$ is positive, so our root is defined.) This is not an indeterminate form: $\lim_{x \rightarrow 0} \sqrt{x^2 \sin^2 x} = 0$.

S-22: $\lim_{x \rightarrow 0} \cos x = 1$ and $\lim_{x \rightarrow 0} \frac{1}{x^2} = \infty$, so $\lim_{x \rightarrow 0} (\cos x)^{\frac{1}{x^2}}$ has the indeterminate form 1^∞ . We want to use l'Hôpital, but we need to get our function into a fractional indeterminate form. So, we'll use a logarithm.

$$\begin{aligned} y &:= (\cos x)^{\frac{1}{x^2}} \\ \log y &= \log \left((\cos x)^{\frac{1}{x^2}} \right) = \frac{1}{x^2} \log(\cos x) = \frac{\log \cos x}{x^2} \\ \lim_{x \rightarrow 0} \log y &= \lim_{x \rightarrow 0} \underbrace{\frac{\log \cos x}{x^2}}_{\substack{\text{num} \rightarrow 0 \\ \text{den} \rightarrow 0}} = \lim_{x \rightarrow 0} \frac{\frac{-\sin x}{\cos x}}{2x} = \lim_{x \rightarrow 0} \underbrace{\frac{-\tan x}{2x}}_{\substack{\text{num} \rightarrow 0 \\ \text{den} \rightarrow 0}} = \lim_{x \rightarrow 0} \frac{-\sec^2 x}{2} \\ &= \lim_{x \rightarrow 0} \frac{-1}{2 \cos^2 x} = -\frac{1}{2} \\ \text{Therefore, } \lim_{x \rightarrow 0} y &= \lim_{x \rightarrow 0} e^{\log y} = e^{-1/2} = \frac{1}{\sqrt{e}} \end{aligned}$$

S-23:

- Solution 1

$$y := e^{x \log x} = (e^x)^{\log x}$$

$$\lim_{x \rightarrow 0^+} y = \lim_{x \rightarrow 0^+} (e^x)^{\log x}$$

This has the form $1^{-\infty} = \frac{1}{1^\infty}$, and 1^∞ is an indeterminate form. We want to use l'Hôpital, but we need to get a different indeterminate form. So, we'll use logarithms.

$$\lim_{x \rightarrow 0^+} \log y = \lim_{x \rightarrow 0^+} \log \left((e^x)^{\log x} \right) = \lim_{x \rightarrow 0^+} \log x \log (e^x) = \lim_{x \rightarrow 0^+} (\log x) \cdot x$$

This has the indeterminate form $0 \cdot \infty$, so we need one last adjustment before we can use l'Hôpital's Rule.

$$= \lim_{x \rightarrow 0^+} \underbrace{\frac{\log x}{\frac{1}{x}}}_{\substack{\text{num} \rightarrow -\infty \\ \text{den} \rightarrow \infty}} = \lim_{x \rightarrow 0^+} \frac{\frac{1}{x}}{\frac{-1}{x^2}} = \lim_{x \rightarrow 0^+} -x = 0$$

Now, we can figure out what happens to our original function, y :

$$\lim_{x \rightarrow 0^+} y = \lim_{x \rightarrow 0^+} e^{\log y} = e^0 = 1$$

- Solution 2

$$y := e^{x \log x} = \left(e^{\log x} \right)^x = x^x$$

$$\lim_{x \rightarrow 0^+} y = \lim_{x \rightarrow 0^+} x^x$$

We have the indeterminate form 0^0 . We want to use l'Hôpital, but we need a different indeterminate form. So, we'll use logarithms.

$$\lim_{x \rightarrow 0^+} \log y = \lim_{x \rightarrow 0^+} \log(x^x) = \lim_{x \rightarrow 0^+} x \log x$$

Now we have the indeterminate form $0 \cdot \infty$, so we need one last adjustment before we can use l'Hôpital's Rule.

$$\lim_{x \rightarrow 0^+} \log y = \lim_{x \rightarrow 0^+} \underbrace{\frac{\log x}{\frac{1}{x}}}_{\substack{\text{num} \rightarrow 0 \\ \text{den} \rightarrow -\infty}} = \lim_{x \rightarrow 0^+} \frac{\frac{1}{x}}{\frac{-1}{x^2}} = \lim_{x \rightarrow 0^+} -x = 0$$

Now, we can figure out what happens to our original function, y :

$$\lim_{x \rightarrow 0^+} y = \lim_{x \rightarrow 0^+} e^{\log y} = e^0 = 1$$

S-24: First, note that the function exists near 0: x^2 is positive, so $\log(x^2)$ exists; near 0, $\log x^2$ is negative, so $-\log(x^2)$ is positive, so $[-\log(x^2)]^x$ exists even when x is negative.

Since $\lim_{x \rightarrow 0} -\log(x^2) = \infty$ and $\lim_{x \rightarrow 0} x = 0$, we have the indeterminate form ∞^0 . We need l'Hôpital, but we need to manipulate our function into an appropriate form. We do this using logarithms.

$$\begin{aligned}
 y &:= [-\log(x^2)]^x \\
 \log y &= \log \left([-\log(x^2)]^x \right) = \underbrace{x}_{\rightarrow 0} \cdot \underbrace{\log \left(\underbrace{-\log(x^2)}_{\rightarrow \infty} \right)}_{\rightarrow \infty} = \frac{\log(-\log(x^2))}{\frac{1}{x}} \\
 \lim_{x \rightarrow 0} \log y &= \lim_{x \rightarrow 0} \underbrace{\frac{\log(-\log(x^2))}{\frac{1}{x}}}_{\substack{\text{num} \rightarrow \infty \\ \text{den} \rightarrow \pm \infty}} = \lim_{x \rightarrow 0} \frac{\frac{-\frac{2}{x}}{-\log(x^2)}}{\frac{-1}{x^2}} = \lim_{x \rightarrow 0} \frac{-2x}{\underbrace{\log(x^2)}_{\substack{\text{num} \rightarrow 0 \\ \text{den} \rightarrow -\infty}}} = 0
 \end{aligned}$$

Now, we're ready to figure out our original limit.

$$\lim_{x \rightarrow 0} y = \lim_{x \rightarrow 0} e^{\log y} = e^0 = 1$$

Solutions to Exercises 7.1 — Jump to [TABLE OF CONTENTS](#)

S-1: In general, this is false. For example, the function $f(x) = \frac{x^2 - 9}{x^2 - 9}$ has no vertical asymptotes, because it is equal to 1 in every point in its domain (and is undefined when $x = \pm 3$).

However, it is certainly *possible* that $f(x)$ has a vertical asymptote at $x = -3$. For example, $f(x) = \frac{1}{x^2 - 9}$ has a vertical asymptote at $x = -3$. More generally, if $g(x)$ is continuous and $g(-3) \neq 0$, then $f(x)$ has a vertical asymptote at $x = -3$.

S-2: Since $x^2 + 1$ and $x^2 + 4$ are always positive, $f(x)$ and $h(x)$ are defined over all real numbers. So, $f(x)$ and $h(x)$ correspond to $A(x)$ and $B(x)$. Which is which? $A(0) = 1 = f(0)$ while $B(0) = 2 = h(0)$, so $A(x) = f(x)$ and $B(x) = h(x)$.

That leaves $g(x)$ and $k(x)$ matching to $C(x)$ and $D(x)$. The domain of $g(x)$ is all x such that $x^2 - 1 \geq 0$. That is, $|x| \geq 1$, like $C(x)$. The domain of $k(x)$ is all x such that $x^2 - 4 \geq 0$. That is, $|x| \geq 2$, like $D(x)$. So, $C(x) = g(x)$ and $D(x) = k(x)$.

S-3: (a) Since $f(0) = 2$, we solve

$$\begin{aligned}2 &= \sqrt{\log^2(0+p)} \\ &= \sqrt{\log^2 p} \\ &= |\log p| \\ \log p &= \pm 2 \\ p &= e^{\pm 2} \\ p &= e^2 \text{ or } p = \frac{1}{e^2}\end{aligned}$$

We know that p is e^2 or $\frac{1}{e^2}$, but we have to decide between the two. In both cases, $f(0) = 2$. Let's consider the domain of $f(x)$. Since $\log^2(x+p)$ is never negative, the square root does not restrict our domain. However, we can only take the logarithm of positive numbers. Therefore, the domain is

$$\begin{aligned}x \text{ such that } x+p &> 0 \\ x \text{ such that } x &> -p\end{aligned}$$

If $p = \frac{1}{e^2}$, then the domain of $f(x)$ is $\left(-\frac{1}{e^2}, \infty\right)$. In particular, since $-\frac{1}{e^2} > -1$, the domain of $f(x)$ does not include $x = -1$. However, it is clear from the graph that $f(-1)$ exists. So, $p = e^2$.

(b) Now, we need to figure out what b is. Notice that b is the end of the domain of $f(x)$, which we already found to be $(-p, \infty)$. So, $b = -p = -e^2$.

(As a quick check, if we take $e \approx 2.7$, then $-e^2 = -7.29$, and this looks about right on the graph.)

(c) The x -intercept is the value of x for which $f(x) = 0$:

$$\begin{aligned}0 &= \sqrt{\log^2(x+p)} \\ 0 &= \log(x+p) \\ 1 &= x+p \\ x &= 1-p = 1-e^2\end{aligned}$$

The x -intercept is $1 - e^2$.

(As another quick check, the x -intercept we found is a distance of 1 from the vertical asymptote, and this looks about right on the graph.)

S-4: Vertical asymptotes occur where the function blows up. In rational functions, this can only happen when the denominator goes to 0. In our case, the denominator is 0 when $x = 3$, and in this case the numerator is 147. That means that as x gets closer and closer to 3, the numerator gets closer and closer to 147 while the denominator gets closer and closer to 0, so $|f(x)|$ grows without bound. That is, there is a vertical asymptote at $x = 3$.

The horizontal asymptotes are found by taking the limits as x goes to infinity and negative infinity. In our case, they are the same, so we condense our work.

$$\lim_{x \rightarrow \pm\infty} \frac{x(2x+1)(x-7)}{3x^3-81} = \lim_{x \rightarrow \pm\infty} \frac{2x^3+ax^2+bx+c}{3x^3-81}$$

where a , b , and c are some constants. Remember, for rational functions, you can figure out the end behaviour by looking only at the terms with the highest degree—the others won't matter, so we don't bother finding them. From here, we divide the numerator and denominator by the highest power of x in the denominator, x^3 .

$$\begin{aligned} &= \lim_{x \rightarrow \pm\infty} \frac{2x^3+ax^2+bx+c}{3x^3-81} \left(\frac{\frac{1}{x^3}}{\frac{1}{x^3}} \right) \\ &= \lim_{x \rightarrow \pm\infty} \frac{2+\frac{a}{x}+\frac{b}{x^2}+\frac{c}{x^3}}{3-\frac{81}{x^3}} \\ &= \frac{2+0+0+0}{3-0} = \frac{2}{3} \end{aligned}$$

So there is a horizontal asymptote of $y = \frac{2}{3}$ both as $x \rightarrow \infty$ and as $x \rightarrow -\infty$.

S-5: Since $f(x)$ is continuous over all real numbers, it has no vertical asymptote.

To find the horizontal asymptotes, we evaluate $\lim_{x \rightarrow \pm\infty} f(x)$.

$$\lim_{x \rightarrow \infty} 10^{3x-7} = \lim_{\substack{X \rightarrow \infty \\ \text{let } X=3x-7}} 10^X = \infty$$

So, there's no horizontal asymptote as $x \rightarrow \infty$.

$$\begin{aligned} \lim_{x \rightarrow -\infty} 10^{3x-7} &= \lim_{X \rightarrow -\infty} 10^X \\ &\quad \text{let } X=3x-7 \\ &= \lim_{\substack{X' \rightarrow \infty \\ \text{let } X'=-X}} 10^{-X'} \\ &= \lim_{X' \rightarrow \infty} \frac{1}{10^{X'}} \\ &= 0 \end{aligned}$$

That is, $y = 0$ is a horizontal asymptote as $x \rightarrow -\infty$.

Solutions to Exercises 7.2 — Jump to [TABLE OF CONTENTS](#)

S-1: Functions $A(x)$ and $B(x)$ share something in common that sets them apart from the others: they have a horizontal tangent line only once. In particular, $A'(-2) \neq 0$ and $B'(2) \neq 0$. The only listed functions that do not have two distinct roots are $l(x)$ and $p(x)$. Since $l(-2) \neq 0$ and $p(2) \neq 0$, we conclude

$$A'(x) = l(x) \quad B'(x) = p(x)$$

Function $C(x)$ is never decreasing. Its tangent line is horizontal when $x = \pm 2$, but the curve never decreases, so $C'(x) \geq 0$ for all x and $C'(2) = C'(-2) = 0$. The only function that matches this is $n(x) = (x-2)^2(x+2)^2$. Since its linear terms have even powers, it is never negative, and its roots are precisely $x = \pm 2$.

$$C'(x) = n(x)$$

For the functions $D(x)$ and $E(x)$ we consider their behaviour near $x = 0$. $D(x)$ is decreasing near $x = 0$, so $D'(0) < 0$, which matches with $o(0) < 0$. Contrastingly, $E(x)$ is increasing near zero, so $E'(0) > 0$, which matches with $m(0) > 0$.

$$D'(x) = o(x) \quad E'(x) = m(x)$$

S-2: The domain of $f(x)$ is all real numbers except -3 (because when $x = -3$ the denominator is zero). For $x \neq -3$, we differentiate using the quotient rule:

$$f'(x) = \frac{e^x(x+3) - e^x(1)}{(x+3)^2} = \frac{e^x}{(x+3)^2}(x+2)$$

Since e^x and $(x+3)^2$ are positive for every x in the domain of $f(x)$, the sign of $f'(x)$ is the same as the sign of $x+2$. We conclude that $f(x)$ is increasing for every x in its domain with $x+2 > 0$. That is, over the open interval $(-2, \infty)$.

S-3: Since we can't take the square root of a negative number, $f(x)$ is only defined when $x \geq 1$. Furthermore, since we can't have zero as a denominator, $x = -2$ is not in the domain — but as long as $x \geq 1$, we also have $x \neq -2$. So, the domain of the function is $[1, \infty)$.

In order to find where $f(x)$ is increasing, we find where $f'(x)$ is positive.

$$f'(x) = \frac{\frac{2x+4}{2\sqrt{x-1}} - 2\sqrt{x-1}}{(2x+4)^2} = \frac{(x+2) - 2(x-1)}{\sqrt{x-1}(2x+4)^2} = \frac{-x+4}{\sqrt{x-1}(2x+4)^2}$$

The denominator is never negative, so $f(x)$ is increasing when the numerator of $f'(x)$ is positive, i.e. when $4-x > 0$, or $x < 4$. Recalling that the domain of definition for $f(x)$ is $[1, +\infty)$, we conclude that $f(x)$ is increasing on the open interval $(1, 4)$.

S-4: The domain of arctangent is all real numbers. The domain of the logarithm function is all positive numbers, and $1+x^2$ is positive for all x . So, the domain of $f(x)$ is all real numbers.

In order to find where $f(x)$ is increasing, we find where $f'(x)$ is positive.

$$f'(x) = \frac{2}{1+x^2} - \frac{2x}{1+x^2} = \frac{2-2x}{1+x^2}$$

Since the denominator is always positive, $f(x)$ is increasing when $2 - 2x > 0$. We conclude that $f(x)$ is increasing on the open interval $(-\infty, 1)$.

Solutions to Exercises 7.3 — Jump to [TABLE OF CONTENTS](#)

S-1:

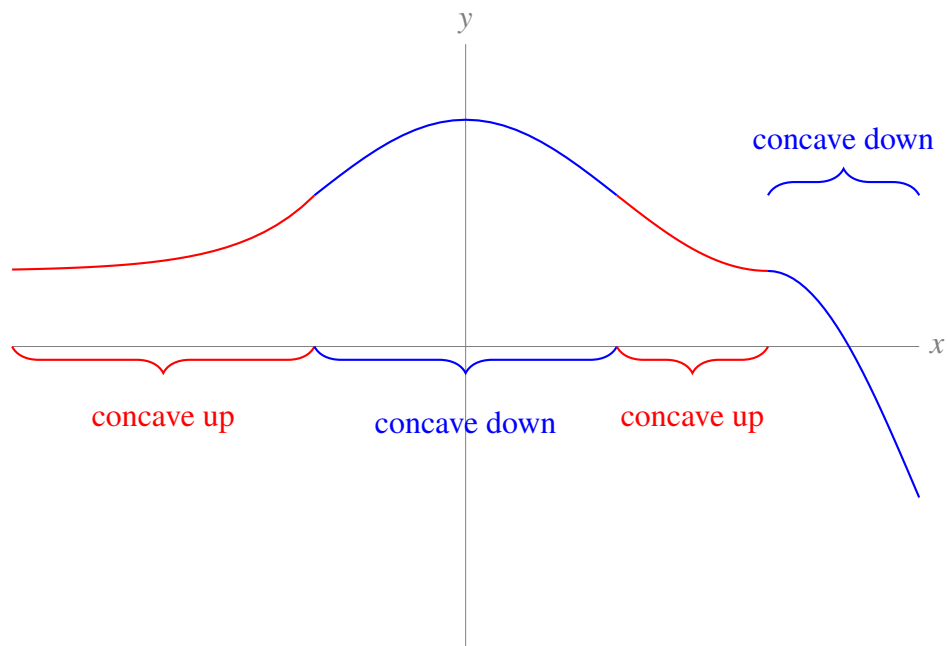

In the graph above, the concave-up sections are marked in red. These are where the graph has an increasing derivative; equivalently, where the graph lies above its tangent lines; more descriptively, where it curves like a smiley face.

Concave-down sections are marked in blue. These are where the graph has a decreasing derivative; equivalently, where the graph lies below its tangent lines; more descriptively, where it curves like a frowney face.

S-2: The most basic shape of the graph is given by the last two bullet points:

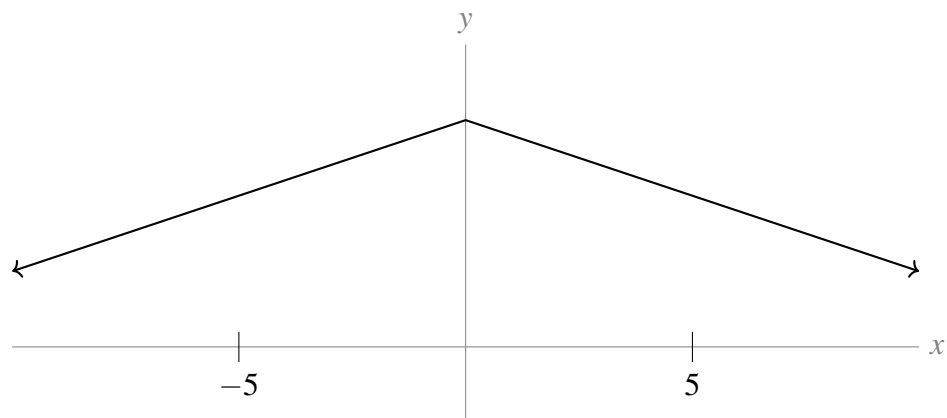

The curve is concave down over the interval $(-5, 5)$, so let's give it a frowney-face curvature there.

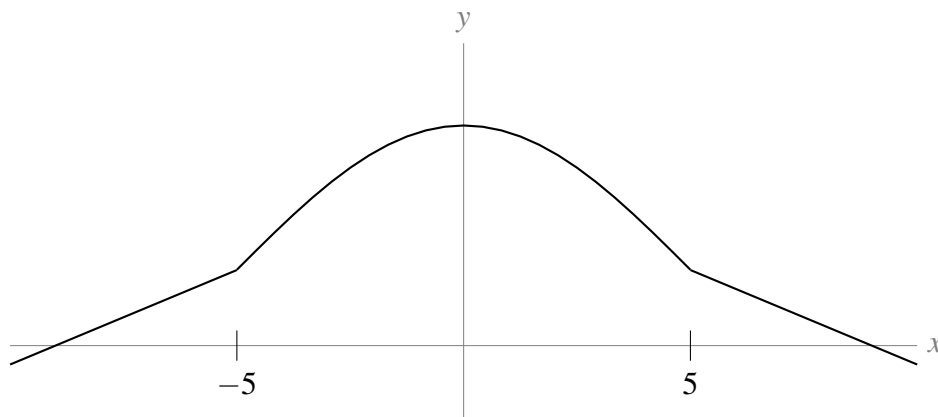

Finally, when $x > 5$ or $x < -5$, our curve should be concave up, so let's give it smiley-face curvature there, without changing its basic increasing/decreasing shape.

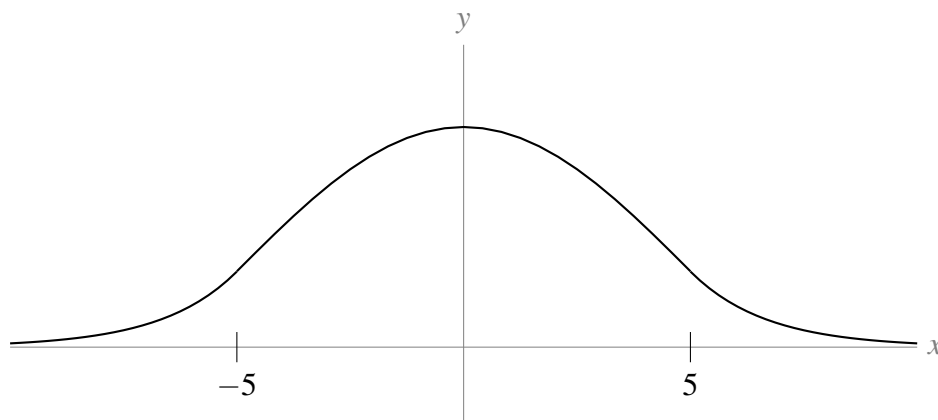

This finishes our sketch.

S-3: An inflection point is where the concavity of a function changes. It is possible that $x = 3$ is an inflection point, but it is also possible that it is not. So, the statement is false, in general.

For example, let $f(x) = (x - 3)^4$. Since $f(x)$ is a polynomial, all its derivatives exist and are continuous. $f''(x) = 12(x - 3)^2$, so $f''(3) = 0$. However, since $f''(x)$ is something squared, it is never negative, so $f(x)$ is never concave down. Since $f(x)$ is never concave down, it never changes concavity, so it has no inflection points.

Remark: finding inflection points is somewhat reminiscent of finding local extrema. To find local extrema, we first find all critical and singular points, since local extrema can only occur there or at endpoints. Then, we have to figure out which critical and singular points are actually local extrema. Similarly, if you want to find inflection points, start by finding where $f''(x)$ is zero or non-existent, because inflection points can only occur there. Then, you still have to check whether those points are actually inflection points.

S-4: Inflection points occur where $f''(x)$ changes sign. Since $f(x)$ is a polynomial, its first and

second derivatives exist everywhere, and are themselves polynomials. In particular,

$$\begin{aligned}f(x) &= 3x^5 - 5x^4 + 13x \\f'(x) &= 15x^4 - 20x^3 + 13 \\f''(x) &= 60x^3 - 60x^2 = 60x^2(x - 1)\end{aligned}$$

The second derivative is negative for $x < 1$ and positive for $x > 1$. Thus the concavity changes between concave up and concave down at $x = 1$, $y = 11$.

This is the only inflection point. It is true that $f''(0) = 0$, but for values of x both a little larger than and a little smaller than 0, $f''(x) < 0$, so the concavity does not change at $x = 0$.

Solutions to Exercises 7.4 — Jump to [TABLE OF CONTENTS](#)

S-1: This function is symmetric across the y -axis, so it is even.

S-2: The function is not even, because it is not mirrored across the y -axis.

Assuming it continues as shown, the function is periodic, because the unit shown below is repeated:

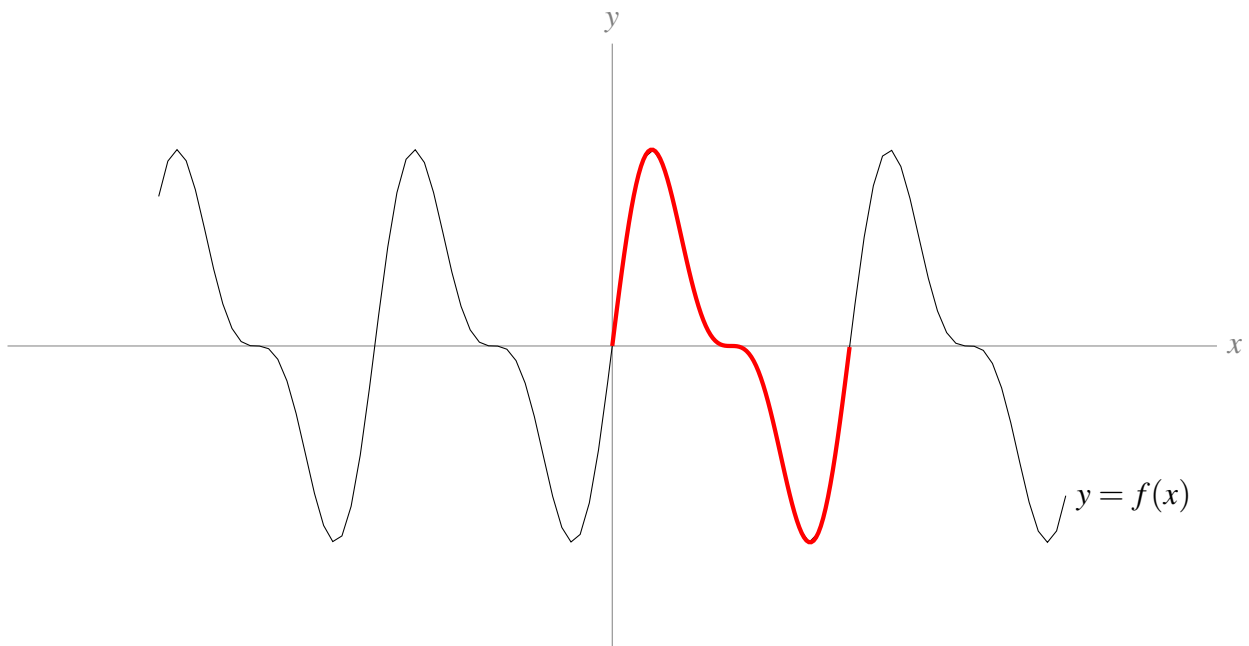

Additionally, $f(x)$ is odd. In a function with odd symmetry, if we mirror the right-hand portion of the curve (the portion to the right of the y -axis) across both the y -axis and the x -axis, it lines up with the left-hand portion of the curve.

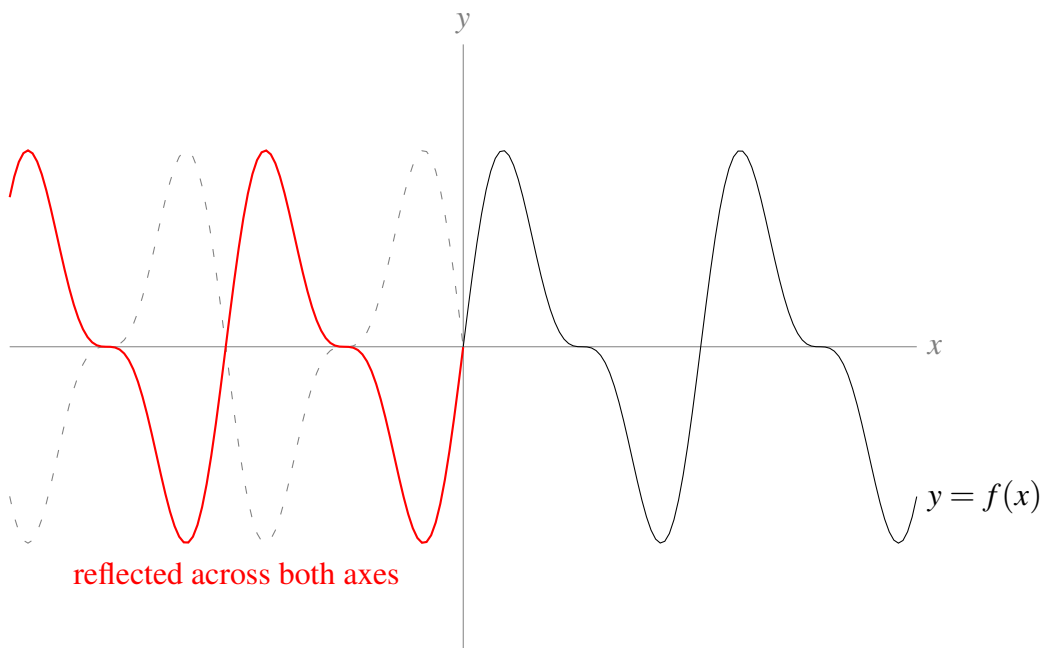
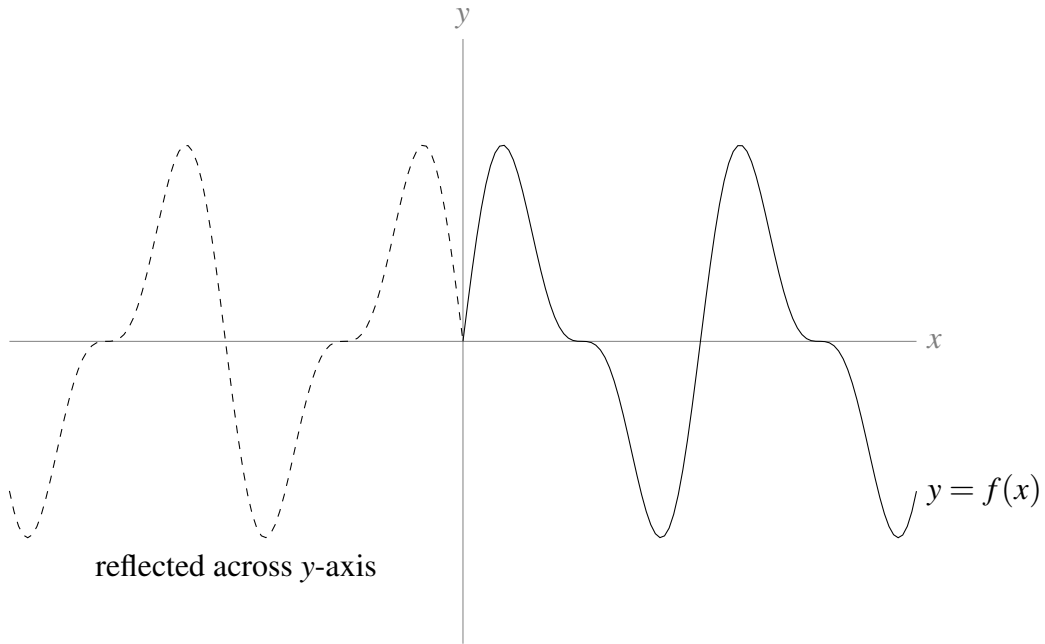

Since reflecting the right-hand portion of the graph across the y -axis, then the x -axis, gives us $f(x)$, we conclude $f(x)$ is odd.

S-3: Since the function is even, we simply reflect the portion shown across the y -axis to complete the sketch.

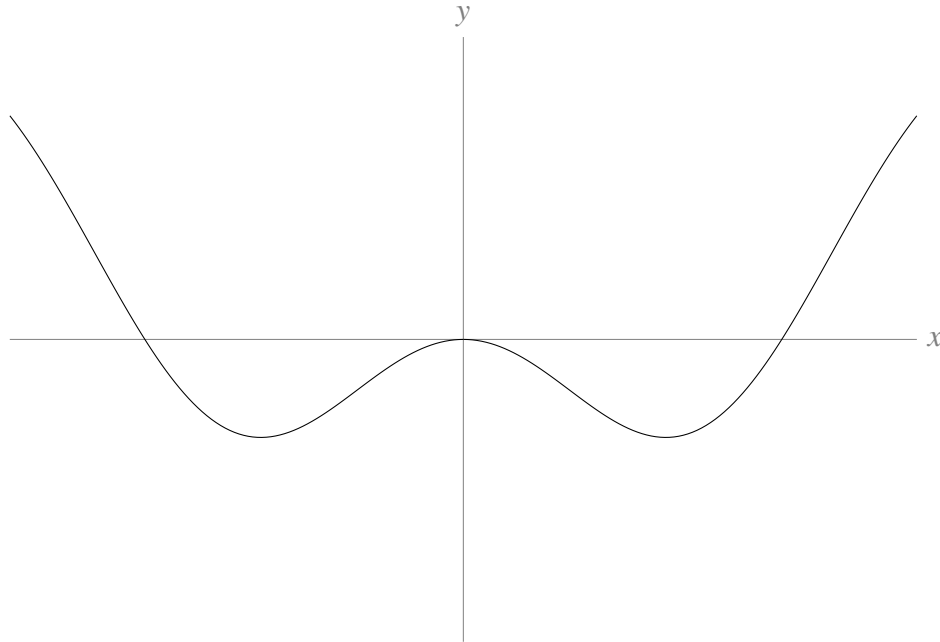

S-4: Since the function is odd, to complete the sketch, we reflect the portion shown across the y -axis (shown dashed), then the x -axis (shown in red).

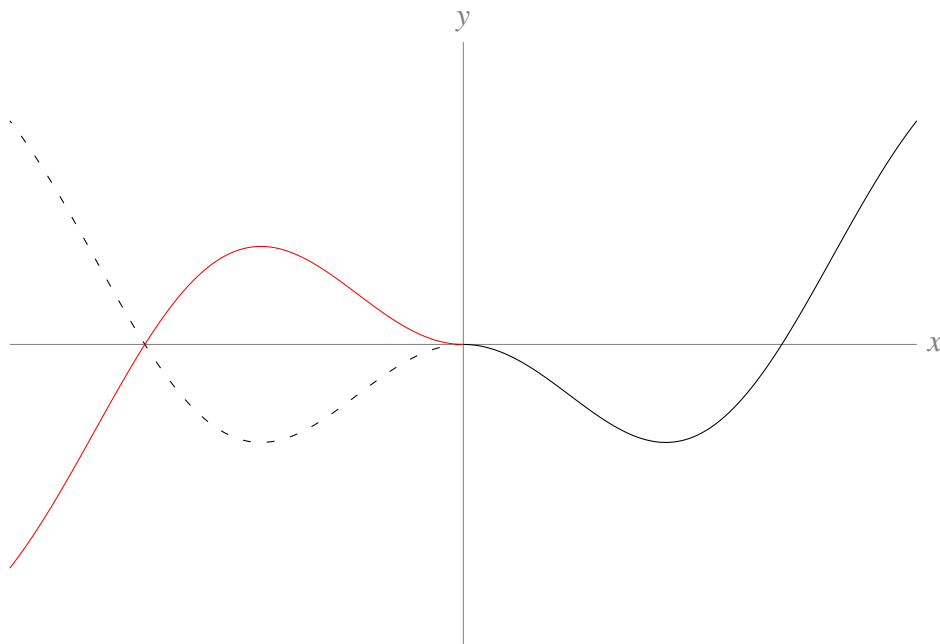

S-5: A function is even if $f(-x) = f(x)$.

$$\begin{aligned} f(-x) &= \frac{(-x)^4 - (-x)^6}{e^{(-x)^2}} \\ &= \frac{x^4 - x^6}{e^{x^2}} \\ &= f(x) \end{aligned}$$

So, $f(x)$ is even.

S-6: For any real number x , we will show that $f(x) = f(x + 4\pi)$.

$$\begin{aligned} f(x + 4\pi) &= \sin(x + 4\pi) + \cos\left(\frac{x + 4\pi}{2}\right) \\ &= \sin(x + 4\pi) + \cos\left(\frac{x}{2} + 2\pi\right) \\ &= \sin(x) + \cos\left(\frac{x}{2}\right) \\ &= f(x) \end{aligned}$$

So, $f(x)$ is periodic.

S-7: $f(x)$ is not periodic. (You don't really have to justify this, but if you wanted to, you could say something like this. Notice $f(0) = 1$. Whenever $x > 10$, $f(x) > 1$. Then the value of $f(0)$ is *not* repeated indefinitely, so $f(x)$ is not periodic.)

To decide whether $f(x)$ is even, odd, or neither, simplify $f(-x)$:

$$\begin{aligned} f(-x) &= (-x)^4 + 5(-x)^2 + \cos((-x)^3) \\ &= x^4 + 5x^2 + \cos(-x) \\ &= x^4 + 5x^2 + \cos(x) \\ &= f(x) \end{aligned}$$

Since $f(-x) = f(x)$, our function is even.

S-8: It should be clear that $f(x)$ is not periodic. (If you wanted to justify this, you could note that $f(x) = 0$ has exactly two solutions, $x = 0, -5$. Since the value of $f(0)$ is repeated only twice, and not indefinitely, $f(x)$ is not periodic.)

To decide whether $f(x)$ is odd, even, or neither, we simplify $f(-x)$.

$$\begin{aligned} f(-x) &= (-x)^5 + 5(-x)^4 \\ &= -x^5 + 5x^4 \end{aligned}$$

We see that $f(-x)$ is not equal to $f(x)$ or to $-f(x)$. For instance, when $x = 1$:

- $f(-x) = f(-1) = 4$,

- $f(x) = f(1) = 6$, and
- $-f(x) = -f(1) = -6$.

Since $f(-x)$ is not equal to $f(x)$ or to $-f(x)$, $f(x)$ is neither even nor odd.

S-9: Recall the period of $g(X) = \tan X$ is π .

$$\tan(X + \pi) = \tan(X) \quad \text{for any } X \text{ in the domain of } \tan X$$

Replacing X with πx :

$$\begin{aligned} \tan(\pi x + \pi) &= \tan(\pi x) && \text{for any } x \text{ in the domain of } \tan(\pi x) \\ \tan(\pi(x + 1)) &= \tan(\pi x) && \text{for any } x \text{ in the domain of } \tan(\pi x) \\ f(x + 1) &= f(x) && \text{for any } x \text{ in the domain of } \tan(\pi x) \end{aligned}$$

The period of $f(x)$ is 1.

S-10: Let's consider $g(x) = \tan(3x)$ and $h(x) = \sin(4x)$ separately. Recall that π is the period of tangent.

$$\tan X = \tan(X + \pi) \quad \text{for every } X \text{ in the domain of } \tan X$$

Replacing X with $3x$:

$$\begin{aligned} \tan(3x) &= \tan(3x + \pi) && \text{for every } x \text{ in the domain of } \tan 3x \\ \tan(3x) &= \tan\left(3\left(x + \frac{\pi}{3}\right)\right) && \text{for every } x \text{ in the domain of } \tan 3x \\ g(x) &= g\left(x + \frac{\pi}{3}\right) && \text{for every } x \text{ in the domain of } \tan 3x \end{aligned}$$

So, the period of $g(x) = \tan(3x)$ is $\frac{\pi}{3}$.

Similarly, 2π is the period of sine.

$$\sin(X) = \sin(X + 2\pi) \quad \text{for every } X \text{ in the domain of } \sin(X)$$

Replacing X with $4x$:

$$\begin{aligned} \sin(4x) &= \sin(4x + 2\pi) && \text{for every } x \text{ in the domain of } \sin(4x) \\ \sin(4x) &= \sin\left(4\left(x + \frac{\pi}{2}\right)\right) && \text{for every } x \text{ in the domain of } \sin(4x) \\ h(x) &= h\left(x + \frac{\pi}{2}\right) && \text{for every } x \text{ in the domain of } \sin(4x) \end{aligned}$$

So, the period of $h(x) = \sin(4x)$ is $\frac{\pi}{2}$.

All together, $f(x) = g(x) + h(x)$ will repeat when both $g(x)$ and $h(x)$ repeat. The least common integer multiple of $\frac{\pi}{3}$ and $\frac{\pi}{2}$ is π . Since $g(x)$ repeats every $\frac{\pi}{3}$ units, and $h(x)$ repeats every $\frac{\pi}{2}$ units, they will not both repeat until we move π units. So, the period of $f(x)$ is π .

No exercises for Section 7.5. — Jump to [TABLE OF CONTENTS](#)

Solutions to Exercises 7.6 — Jump to [TABLE OF CONTENTS](#)

S-1: (a) Since we must have $3 - x \geq 0$, this tells us $x \leq 3$. So, the domain is $(-\infty, 3]$.

(b)

$$f'(x) = \sqrt{3-x} - \frac{x}{2\sqrt{3-x}} = 3 \frac{2-x}{2\sqrt{3-x}}$$

For every x in the domain of $f'(x)$, the denominator is positive, so the sign of $f'(x)$ depends only on the numerator.

x	$(-\infty, 2)$	2	$(2, 3)$	3
$f'(x)$	positive	0	negative	DNE
$f(x)$	increasing	maximum	decreasing	endpoint

So, f is increasing for $x < 2$, has a local (in fact global) maximum at $x = 2$, is decreasing for $2 < x < 3$, and has a local minimum at $x = 3$.

Remark: this shows us the basic skeleton of the graph. It consists of a single hump.

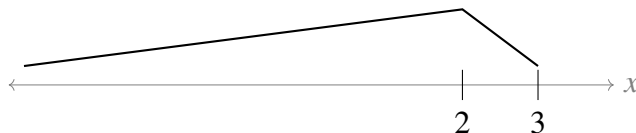

(c) When $x < 3$,

$$f''(x) = \frac{1}{4}(3x-12)(3-x)^{-3/2} < 0$$

The domain of $f''(x)$ is $(-\infty, 3)$, and over its domain it is always negative (the factor $(3x-12)$ is negative for all $x < 4$ and the factor $(3-x)^{-3/2}$ is positive for all $x < 3$). So, $f(x)$ has no inflection points and is concave down everywhere.

(d) We already found

$$f'(x) = 3 \frac{2-x}{2\sqrt{3-x}}.$$

This is undefined at $x = 3$. Indeed,

$$\lim_{x \rightarrow 3^-} 3 \frac{2-x}{2\sqrt{3-x}} = -\infty,$$

so $f(x)$ has a vertical tangent line at $(3, 0)$.

(e) To sketch the curve $y = f(x)$, we already know its intervals of increase and decrease, and its concavity. We also note its intercepts are $(0, 0)$ and $(3, 0)$.

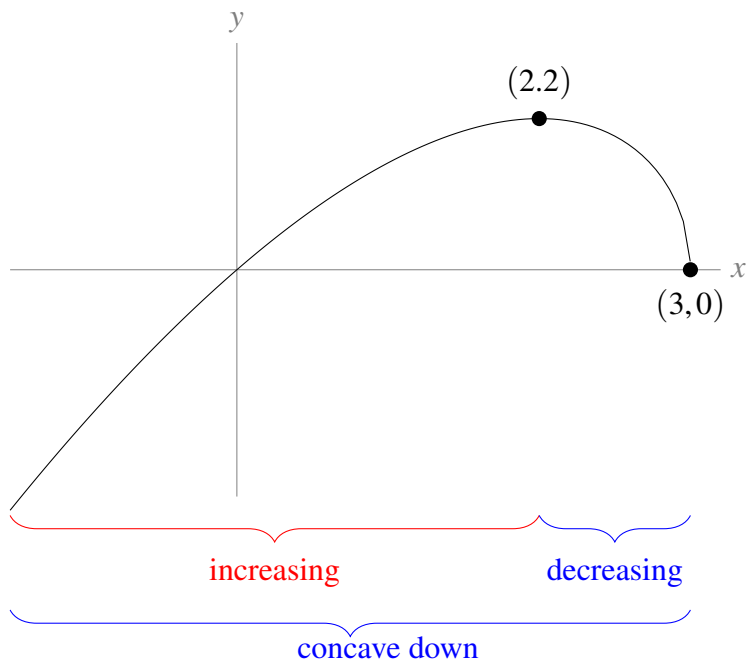

S-2:

- Asymptotes:

$$\lim_{x \rightarrow \pm\infty} f(x) = \lim_{x \rightarrow \pm\infty} \frac{1}{x} - \frac{2}{x^4} = 0$$

So $y = 0$ is a horizontal asymptote both at $x = \infty$ and $x = -\infty$.

$$\lim_{x \rightarrow 0} f(x) = \lim_{x \rightarrow 0} \frac{x^3 - 2}{x^4} = -\infty$$

So there is a vertical asymptote at $x = 0$, where the function plunges downwards from both the right and the left.

- Intervals of increase and decrease:

$$f'(x) = -\frac{1}{x^2} + \frac{8}{x^5} = \frac{8 - x^3}{x^5}$$

The only place where $f'(x)$ is zero only at $x = 2$. So $f(x)$ has a horizontal tangent at $x = 2$, $y = \frac{3}{8}$. This is a critical point.

The derivative is undefined at $x = 0$, as is the function.

x	$(-\infty, 0)$	0	$(0, 2)$	2	$(2, \infty)$
$f'(x)$	negative	DNE	positive	0	negative
$f(x)$	decreasing	vertical asymptote	increasing	local max	decreasing

Since the function changes from increasing to decreasing at $x = 2$, the only local maximum is at $x = 2$.

At this point, we get a rough sketch of $f(x)$.

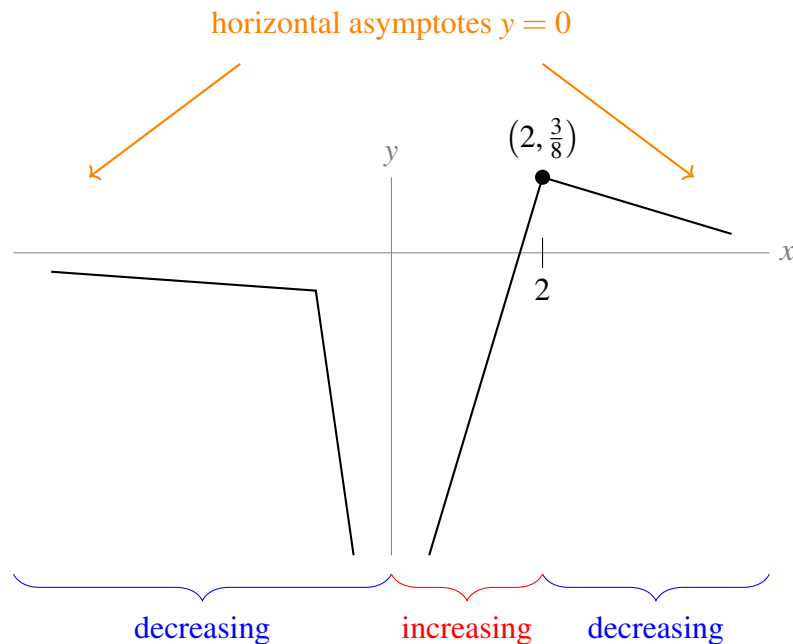

- Concavity:

$$f''(x) = \frac{2}{x^3} - \frac{40}{x^6} = \frac{2x^3 - 40}{x^6}$$

The second derivative of $f(x)$ is positive for $x > \sqrt[3]{20}$ and negative for $x < \sqrt[3]{20}$. So the curve is concave up for $x > \sqrt[3]{20}$ and concave down for $x < \sqrt[3]{20}$. There is an inflection point at $x = \sqrt[3]{20} \approx 2.7$, $y = \frac{18}{20^{4/3}} \approx 0.3$.

- Intercepts:

Since $f(x)$ is not defined at $x = 0$, there is no y -intercept. The only x -intercept is $x = \sqrt[3]{2} \approx 1.3$.

- Sketch:

We can add concavity to our skeleton sketched above, and label our intercept and inflection point (the open dot).

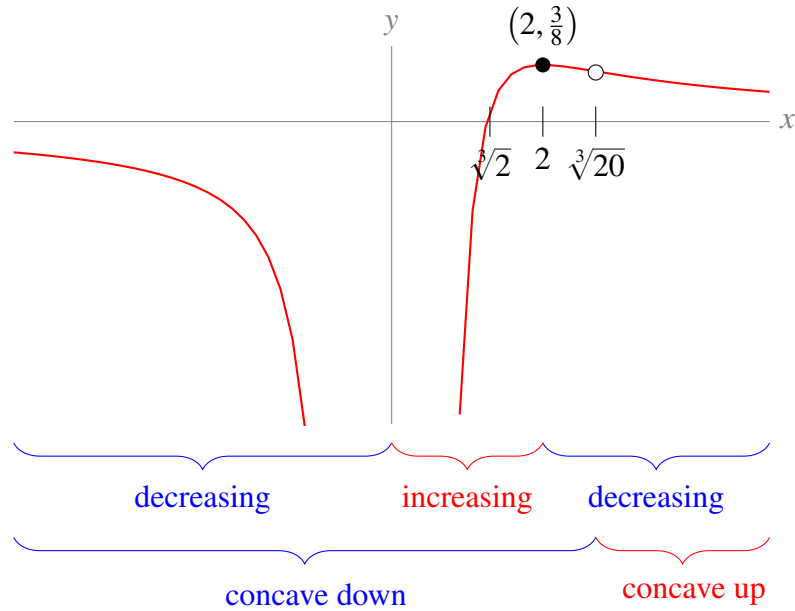

S-3:

- Asymptotes:

When $x = -1$, the denominator $1 + x^3$ of $f(x)$ is zero while the numerator is 1, so $x = -1$ is a vertical asymptote. More precisely,

$$\lim_{x \rightarrow -1^-} f(x) = -\infty \quad \lim_{x \rightarrow -1^+} f(x) = \infty$$

There are no horizontal asymptotes, because

$$\lim_{x \rightarrow \infty} \frac{x^4}{1 + x^3} = \infty \quad \lim_{x \rightarrow -\infty} \frac{x^4}{1 + x^3} = -\infty$$

- Intervals of increase and decrease:

We note that $f'(x)$ is defined for all $x \neq -1$ and is not defined for $x = -1$. Therefore, the only singular point for $f(x)$ is $x = -1$.

To find critical points, we set

$$\begin{aligned} f'(x) &= 0 \\ 4x^3 + x^6 &= 0 \\ x^3(4 + x^3) &= 0 \\ x^3 = 0 &\quad \text{or} \quad 4 + x^3 = 0 \\ x = 0 &\quad \text{or} \quad x = -\sqrt[3]{4} \approx -1.6 \end{aligned}$$

At these critical points, $f(0) = 0$ and $f(-\sqrt[3]{4}) = \frac{4\sqrt[3]{4}}{-3} < 0$. The denominator of $f'(x)$ is never negative, so the sign of $f'(x)$ is the same as the sign of its numerator, $x^3(4 + x^3)$.

x	$(-\infty, -\sqrt[3]{4})$	$-\sqrt[3]{4}$	$(-\sqrt[3]{4}, -1)$	-1	$(-1, 0)$	0	$(0, \infty)$
$f'(x)$	positive	0	negative	DNE	negative	0	positive
$f(x)$	increasing	l. max	decreasing	VA	decreasing	l. min	increasing

Now, we have enough information to make a skeleton of our graph.

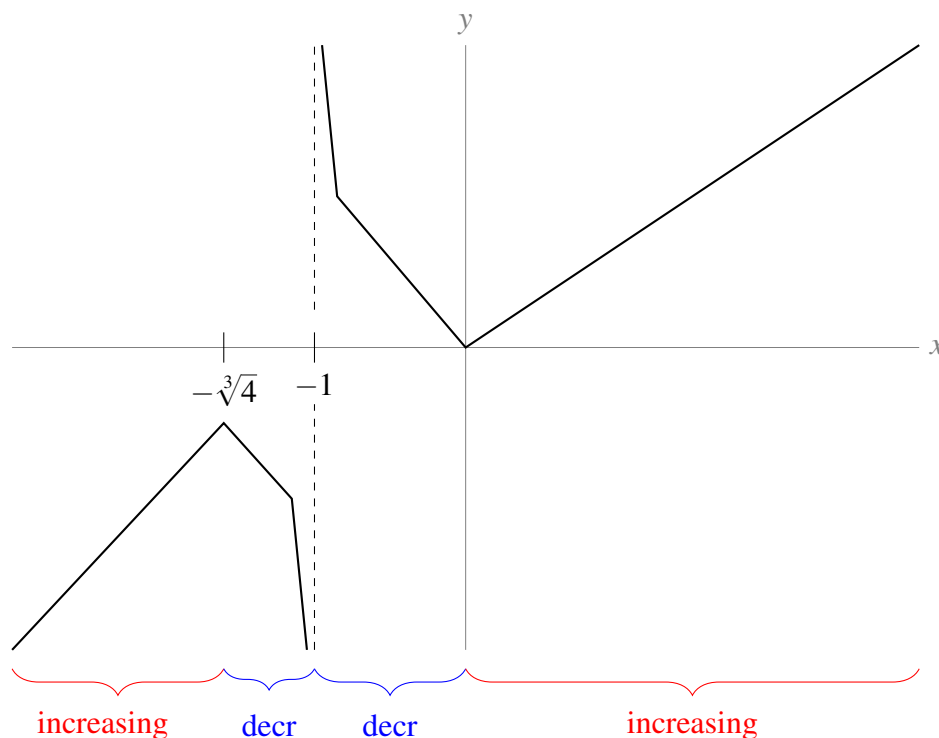

- Concavity:

The second derivative is undefined when $x = -1$. It is zero when $12x^2 - 6x^5 = 6x^2(2 - x^3) = 0$. That is, at $x = \sqrt[3]{2} \approx 1.3$ and $x = 0$. Notice that the sign of $f''(x)$ does not change at $x = 0$, so $x = 0$ is not an inflection point.

x	$(-\infty, -1)$	-1	$(-1, 0)$	0	$(0, \sqrt[3]{2})$	$\sqrt[3]{2}$	$(\sqrt[3]{2}, \infty)$
$f''(x)$	negative	DNE	positive	0	positive	0	negative
$f(x)$	concave down	VA	concave up		concave up	IP	concave down

Now we can refine our skeleton by adding concavity.

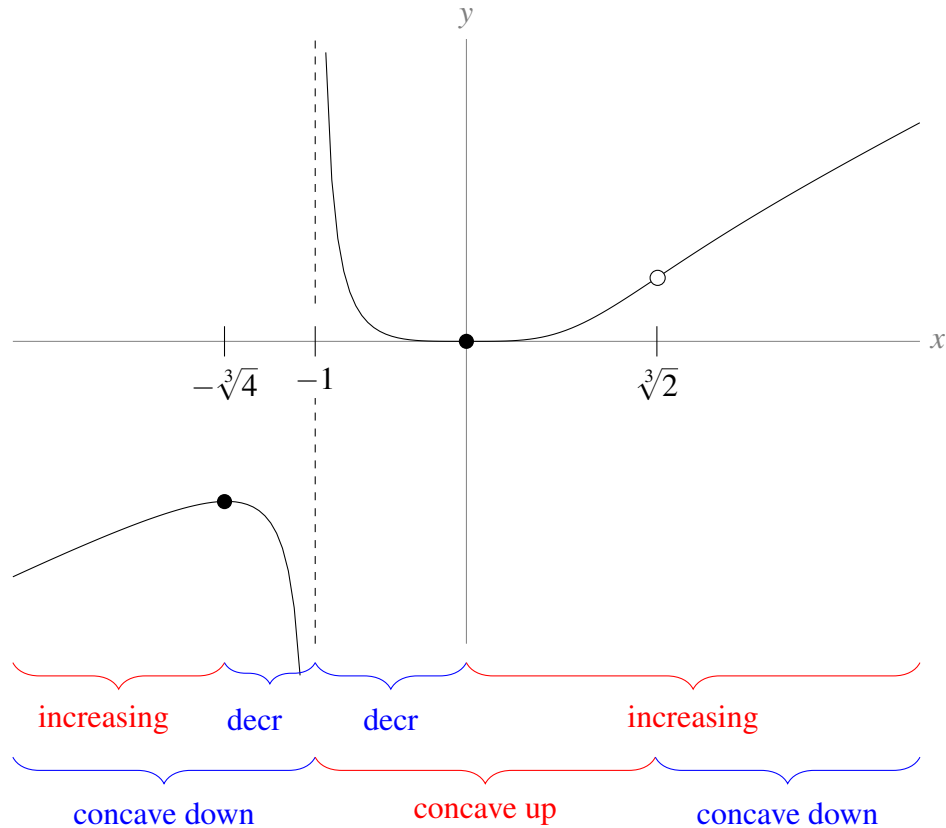

S-4:

- Asymptotes:

$$\lim_{x \rightarrow -\infty} \frac{x^3}{1-x^2} = \infty \quad \lim_{x \rightarrow \infty} \frac{x^3}{1-x^2} = -\infty$$

So, $f(x)$ has no horizontal asymptotes.

On the other hand $f(x)$ blows up at both $x = 1$ and $x = -1$, so there are vertical asymptotes at $x = 1$ and $x = -1$. More precisely,

$$\begin{aligned} \lim_{x \rightarrow -1^-} \frac{x^3}{1-x^2} &= \infty & \lim_{x \rightarrow -1^+} \frac{x^3}{1-x^2} &= -\infty \\ \lim_{x \rightarrow 1^-} \frac{x^3}{1-x^2} &= \infty & \lim_{x \rightarrow 1^+} \frac{x^3}{1-x^2} &= -\infty \end{aligned}$$

- Symmetry:

$f(x)$ is an odd function, because

$$f(-x) = \frac{(-x)^3}{1-(-x)^2} = \frac{-x^3}{1-x^2} = -f(x)$$

- Intercepts:

The only intercept of $f(x)$ is the origin. In particular, that means that out of the three intervals where it is continuous, namely $(-\infty, -1)$, $(-1, 1)$ and $(1, \infty)$, in two of them $f(x)$ is always positive or always negative.

- When $x < -1$: $1 - x^2 < 0$ and $x^3 < 0$, so $f(x) > 0$.
- When $x > 1$: $1 - x^2 < 0$ and $x^3 > 0$, so $f(x) < 0$.
- When $-1 < x < 0$, $1 - x^2 > 0$ and $x^3 < 0$ so $f(x) < 0$.
- When $0 < x < 1$, $1 - x^2 > 0$ and $x^3 > 0$ so $f(x) > 0$.

- Intervals of increase and decrease:

$$f'(x) = \frac{3x^2 - x^4}{(1 - x^2)^2} = \frac{x^2(3 - x^2)}{(1 - x^2)^2}$$

The only singular points are $x = \pm 1$, where $f(x)$, and hence $f'(x)$, is not defined. The critical points are:

$$\begin{aligned} f'(x) &= 0 \\ x^2 &= 0 \quad \text{or} \quad 3 - x^2 = 0 \\ x &= 0 \quad \text{or} \quad x = \pm\sqrt{3} \approx \pm 1.7 \end{aligned}$$

The values of f at its critical points are $f(0) = 0$, $f(\sqrt{3}) = -\frac{3\sqrt{3}}{2} \approx -2.6$ and $f(-\sqrt{3}) = \frac{3\sqrt{3}}{2} \approx 2.6$.

Notice the sign of $f'(x)$ is the same as the sign of $3 - x^2$.

x	$(-\infty, -\sqrt{3})$	$-\sqrt{3}$	$(-\sqrt{3}, -1)$	-1
$f'(x)$	negative	0	positive	DNE
$f(x)$	decreasing	local min	increasing	VA

x	$(-1, 0)$	0	$(0, \sqrt{3})$	$\sqrt{3}$	$(\sqrt{3}, \infty)$
$f'(x)$	positive	0	positive	0	negative
$f(x)$	increasing		increasing	local max	decreasing

Now we have enough information to sketch a skeleton of $f(x)$.

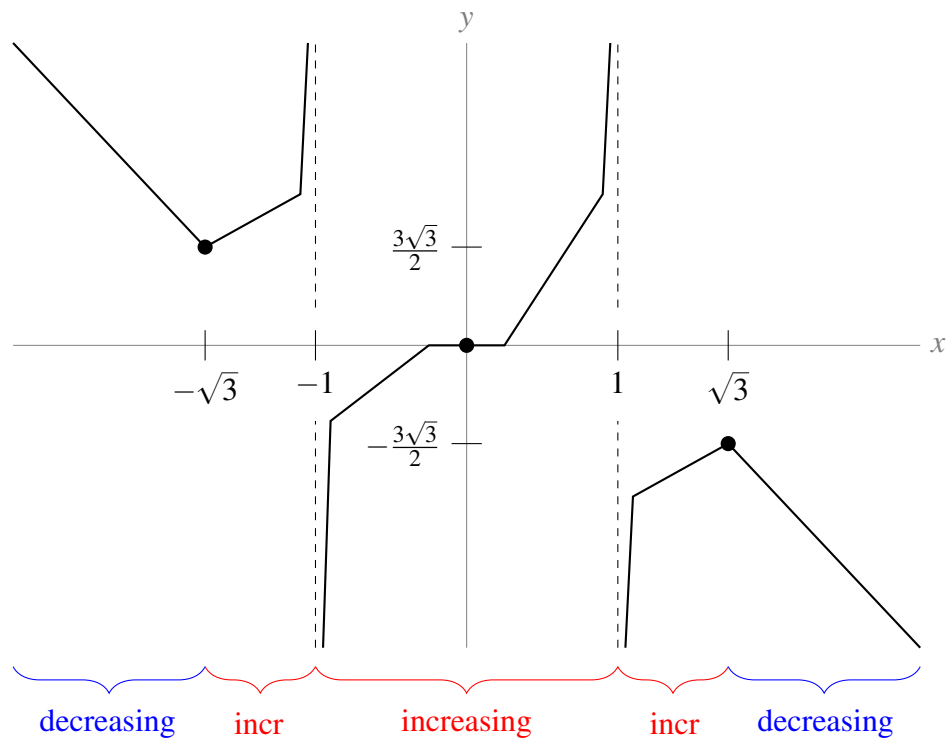

- Concavity:

$$f''(x) = \frac{2x(3+x^2)}{(1-x^2)^3}$$

The second derivative is zero when $x = 0$, and is undefined when $x = \pm 1$.

x	$(-\infty, -1)$	$(-1, 0)$	0	$(0, 1)$	$(1, \infty)$
$f''(x)$	positive	negative	0	positive	negative
$f(x)$	concave up	concave down	inflection point	concave up	concave down

Now, we can refine our skeleton.

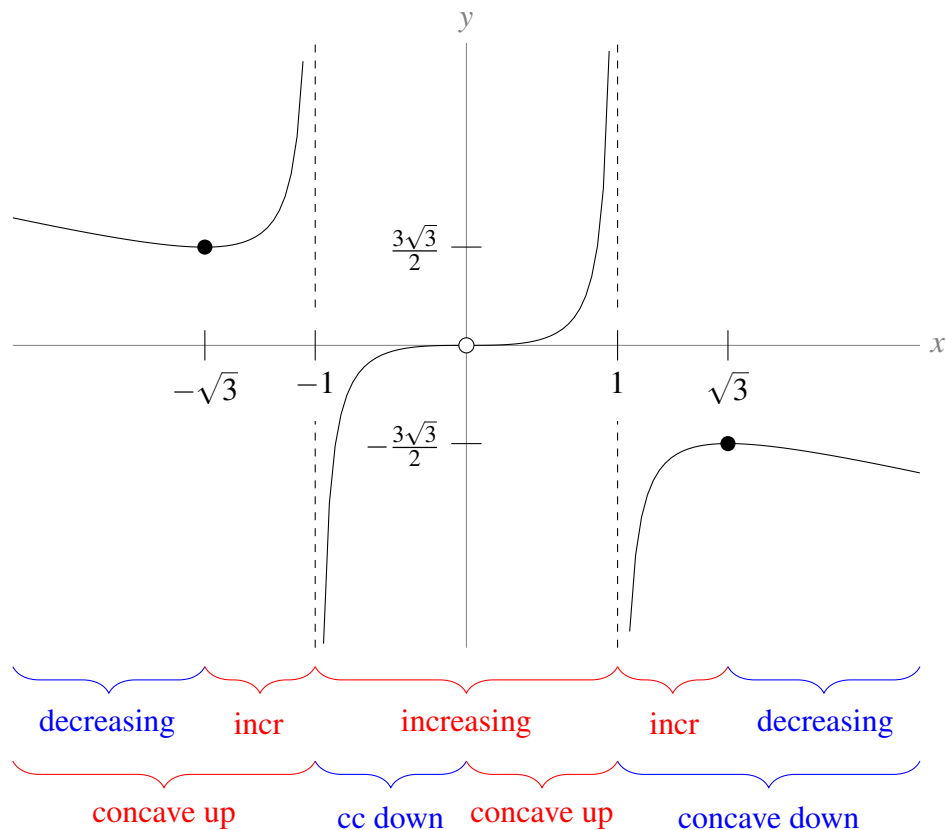

S-5: (a) One branch of the function, the exponential function e^x , is continuous everywhere. So $f(x)$ is continuous for $x < 0$. When $x \geq 0$, $f(x) = \frac{x^2 + 3}{3(x + 1)}$, which is continuous whenever $x \neq -1$ (so it's continuous for all $x > 0$). So, $f(x)$ is continuous for $x > 0$. To see that $f(x)$ is continuous at $x = 0$, we see:

$$\lim_{x \rightarrow 0^-} f(x) = \lim_{x \rightarrow 0^-} e^x = 1$$

$$\lim_{x \rightarrow 0^+} f(x) = \lim_{x \rightarrow 0^+} \frac{x^2 + 3}{3(x + 1)} = 1$$

So, $\lim_{x \rightarrow 0} f(x) = 1 = f(0)$

Hence $f(x)$ is continuous at $x = 0$, so $f(x)$ is continuous everywhere.

(b) We differentiate the function twice. Notice

$$\begin{aligned} \frac{d}{dx} \left\{ \frac{x^2 + 3}{3(x+1)} \right\} &= \frac{3(x+1)(2x) - (x^2 + 3)(3)}{9(x+1)^2} \\ &= \frac{x^2 + 2x - 3}{3(x+1)^2} \\ &= \frac{(x-1)(x+3)}{3(x+1)^2} \quad \text{where } x \neq -1 \end{aligned}$$

Then $\lim_{x \rightarrow 0^+} f'(x) = \frac{(0-1)(0+3)}{3(0+1)^2} = -1 \neq 1 = e^0 = \lim_{x \rightarrow 0^-} f'(x)$

$$\text{so } f'(x) = \begin{cases} e^x & x < 0 \\ DNE & x = 0 \\ \frac{(x-1)(x+3)}{3(x+1)^2} & x > 0 \end{cases}$$

Differentiating again,

$$\begin{aligned} \frac{d^2}{dx^2} \left\{ \frac{x^2 + 3}{3(x+1)} \right\} &= \frac{d}{dx} \left\{ \frac{x^2 + 2x - 3}{3(x+1)^2} \right\} \\ &= \frac{3(x+1)^2(2x+2) - (x^2 + 2x - 3)(6)(x+1)}{9(x+1)^4} \left(\frac{\div 3(x+1)}{\div 3(x+1)} \right) \\ &= \frac{(x+1)(2x+2) - 2(x^2 + 2x - 3)}{3(x+1)^3} \\ &= \frac{8}{3(x+1)^3} \quad \text{where } x \neq -1 \end{aligned}$$

$$\text{so } f''(x) = \begin{cases} e^x & x < 0 \\ DNE & x = 0 \\ \frac{8}{3(x+1)^3} & x > 0 \end{cases}$$

i. The only singular point is $x = 0$, and the only critical point is $x = 1$. (When you're reading off the expression for $f'(x)$, remember that the bottom line only applies when $x > 0$.)

x	$(-\infty, 0)$	0	$(0, 1)$	1	$(1, \infty)$
$f'(x)$	positive	DNE	negative	0	positive
$f(x)$	increasing	local max	decreasing	local min	increasing

The coordinates of the local maximum are $(0, 1)$ and the coordinates of the local minimum are $(1, \frac{2}{3})$.

ii.

When $x \neq 0$, $f''(x)$ is always positive, so $f(x)$ is concave up.

iii.

$$\begin{aligned}\lim_{x \rightarrow \infty} f(x) &= \lim_{x \rightarrow \infty} \frac{x^2 + 3}{3x + 3} \\ &= \lim_{x \rightarrow \infty} \frac{x + \frac{3}{x}}{1 + \frac{3}{x}} = \infty\end{aligned}$$

So, there is no horizontal asymptote to the right.

$$\lim_{x \rightarrow -\infty} f(x) = \lim_{x \rightarrow -\infty} e^x = 0$$

So, $y = 0$ is a horizontal asymptote to the left.

Since $f(x)$ is continuous everywhere, there are no vertical asymptotes.

(c)

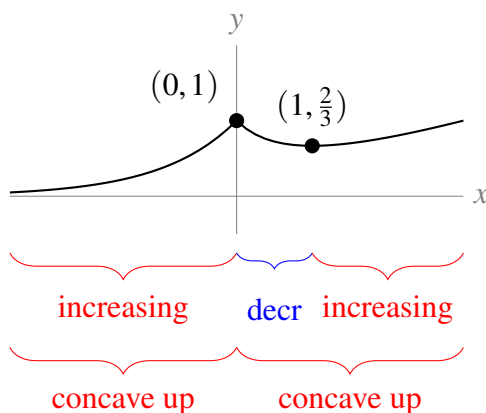

S-6:

- Asymptotes: In the problem statement, we are told:

$$\lim_{x \rightarrow \pm\infty} \frac{1 + 2x}{e^{x^2}} = 0$$

So, $y = 0$ is a horizontal asymptote both at $x = \infty$ and at $x = -\infty$.

Since $f(x)$ is continuous, it has no vertical asymptotes.

- Intervals of increase and decrease:

The critical points are the zeroes of $1 - x - 2x^2 = (1 - 2x)(1 + x)$. That is, $x = \frac{1}{2}, -1$.

x	$(-\infty, -1)$	-1	$(-1, \frac{1}{2})$	$\frac{1}{2}$	$(\frac{1}{2}, \infty)$
$f'(x)$	negative	0	positive	0	negative
$f(x)$	decreasing	local min	increasing	local max	decreasing

At these critical points, $f(\frac{1}{2}) = 2e^{-1/4} > 0$ and $f(-1) = -e^{-1} < 0$.

From here, we can sketch a skeleton of the graph.

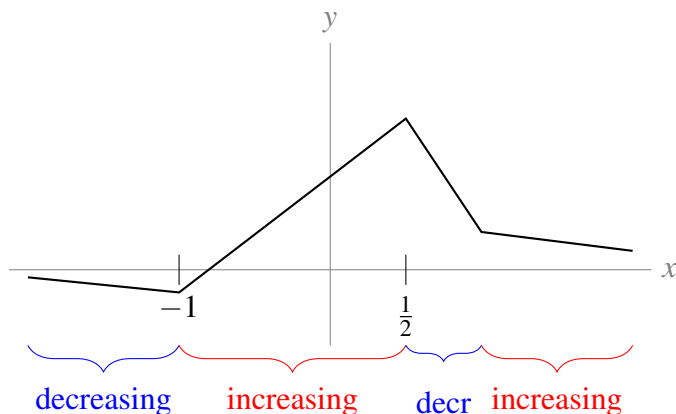

- Concavity:

We are told that we don't have to actually solve for the inflection points. We just need to know enough to get a basic idea. So, we'll turn the skeleton of the graph into smooth curve.

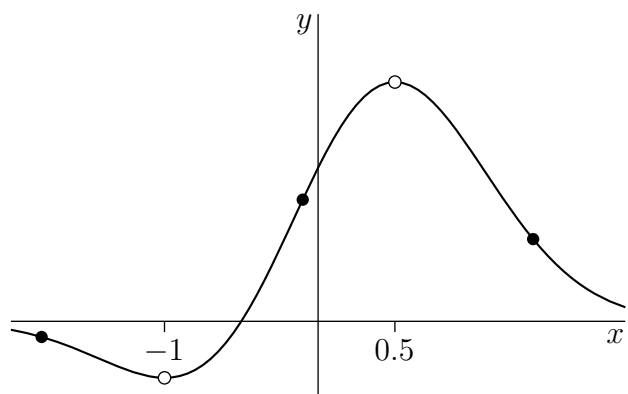

Inflection points are points where the convexity changes from up to down or vice versa. It looks like our graph is convex down for x from $-\infty$ to about -1.8 , convex up from about $x = -1.8$ to about $x = -0.1$, convex down from about $x = -0.1$ to about $x = 1.4$ and convex up from about $x = 1.4$ to infinity. So there are three inflection points at roughly $x = -1.8, -0.1, 1.4$.

S-7:

(a) We need to know the first and second derivative of $f(x)$. Using the product and chain rules, $f'(x) = e^{-x^2/2}(1 - x^2)$. Given to us is $f''(x) = (x^3 - 3x)e^{-x^2/2}$. (These derivatives are also easy to find using the formula developed in Question 20, Section 3.4.)

Since $e^{-x^2/2}$ is always positive, the sign of $f'(x)$ is the same as the sign of $1 - x^2$. $f(x)$ has no singular points and its only critical points are $x = \pm 1$. At these critical points, $f(-1) = -\frac{1}{\sqrt{e}}$ and $f(1) = \frac{1}{\sqrt{e}}$.

x	$(-\infty, -1)$	-1	$(-1, 1)$	1	$(1, \infty)$
$f'(x)$	negative	0	positive	0	negative
$f(x)$	decreasing	local min	increasing	local max	decreasing

This, together with the observations that $f(x) < 0$ for $x < 0$, $f(0) = 0$ and $f(x) > 0$ for $x > 0$ (in fact f is an odd function), is enough to sketch a skeleton of our graph.

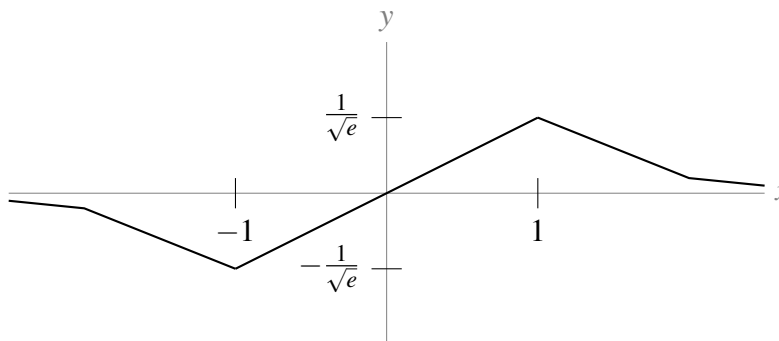

We can factor $f''(x) = (x^3 - 3x)e^{-x^2/2} = x(x + \sqrt{3})(x - \sqrt{3})e^{-x^2/2}$. Since $e^{-x^2/2}$ is always positive, the sign of $f''(x)$ is the same as the sign of $x(x + \sqrt{3})(x - \sqrt{3})$.

x	$(-\infty, -\sqrt{3})$	$-\sqrt{3}$	$(-\sqrt{3}, 0)$	0	$(0, \sqrt{3})$	$\sqrt{3}$	$(\sqrt{3}, \infty)$
$f''(x)$	negative	0	positive	0	negative	0	positive
$f(x)$	concave down	IP	concave up	IP	concave down	IP	concave up

(b) We've already seen that $f(x)$ has a local min at $x = -1$ and a local max at $x = 1$.

As x tends to negative infinity, $f(x)$ tends to 0, and $f(x)$ is decreasing on $(-\infty, -1)$. Then $f(x)$ is between 0 and $f(-1) = \frac{-1}{\sqrt{e}}$ on $(-\infty, -1)$. Then $f(x)$ is increasing on $(-1, 1)$ from $f(-1) = \frac{-1}{\sqrt{e}}$ to $f(1) = \frac{1}{\sqrt{e}}$. Finally, for $x > 1$, $f(x)$ is decreasing from $f(1) = \frac{1}{\sqrt{e}}$ and tending to 0. So when $x > 1$, $f(x)$ is between $\frac{1}{\sqrt{e}}$ and 0.

So, over its entire domain, $f(x)$ is between $\frac{-1}{\sqrt{e}}$ and $\frac{1}{\sqrt{e}}$, and it only achieves those values at $x = -1$ and $x = 1$, respectively. Therefore, the local and global min of $f(x)$ is at $(-1, \frac{-1}{\sqrt{e}})$, and the local and global max of $f(x)$ is at $(1, \frac{1}{\sqrt{e}})$.

(c) In the graph below, open dots are inflection points, and solid dots are extrema.

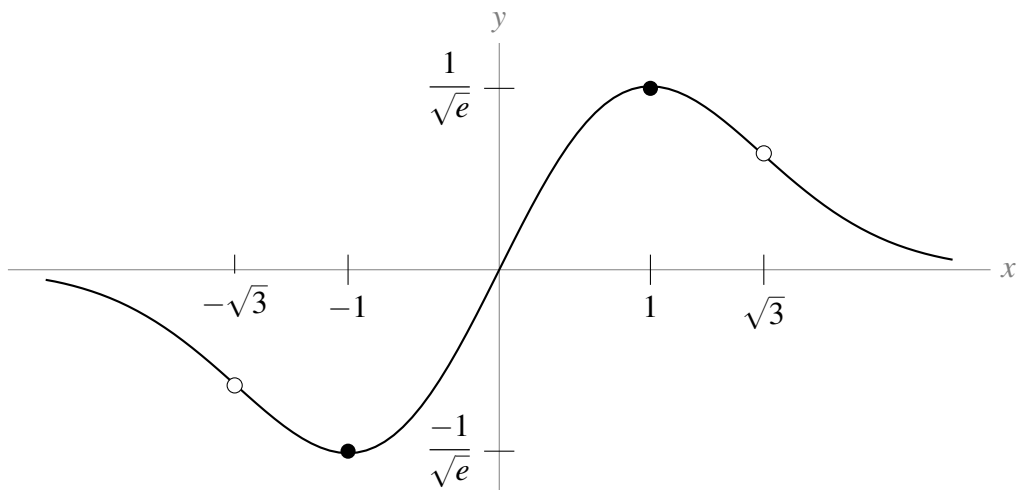

S-8:

- Symmetry:

$$f(-x) = -x + 2 \sin(-x) = -x - 2 \sin x = -f(x)$$

So, $f(x)$ is an odd function. If we can sketch $y = f(x)$ for nonnegative x , we can use symmetry to complete the curve for all x .

- Asymptotes:

Since $f(x)$ is continuous, it has no vertical asymptotes. It also has no horizontal asymptotes, since

$$\lim_{x \rightarrow -\infty} f(x) = -\infty \quad \lim_{x \rightarrow \infty} f(x) = \infty$$

- Intervals of increase and decrease:

Since $f(x)$ is differentiable everywhere, there are no singular points.

$$f'(x) = 1 + 2 \cos x$$

So, the critical points of $f(x)$ occur when

$$\begin{aligned} \cos x &= -\frac{1}{2} \\ x &= 2\pi n \pm \frac{2\pi}{3} \text{ for any integer } n \end{aligned}$$

For instance, $f(x)$ has critical points at $x = \frac{2\pi}{3}$, $x = \frac{4\pi}{3}$, $x = \frac{8\pi}{3}$, and $x = \frac{10\pi}{3}$.

From the unit circle, or the graph of $y = 1 + 2 \cos x$, we see:

x	$(-\frac{2\pi}{3}, \frac{2\pi}{3})$	$\frac{2\pi}{3}$	$(\frac{2\pi}{3}, \frac{4\pi}{3})$	$\frac{4\pi}{3}$	$(\frac{4\pi}{3}, \frac{8\pi}{3})$	$\frac{8\pi}{3}$	$(\frac{8\pi}{3}, \frac{10\pi}{3})$
$f'(x)$	positive	0	negative	0	positive	0	negative
$f(x)$	increasing	l. max	decreasing	l. min	increasing	l. max	decreasing

We have enough information to sketch a skeleton of the curve $y = f(x)$. We use the pattern above for the graph to the right of the y -axis, and use odd symmetry for the graph to the left of the y -axis.

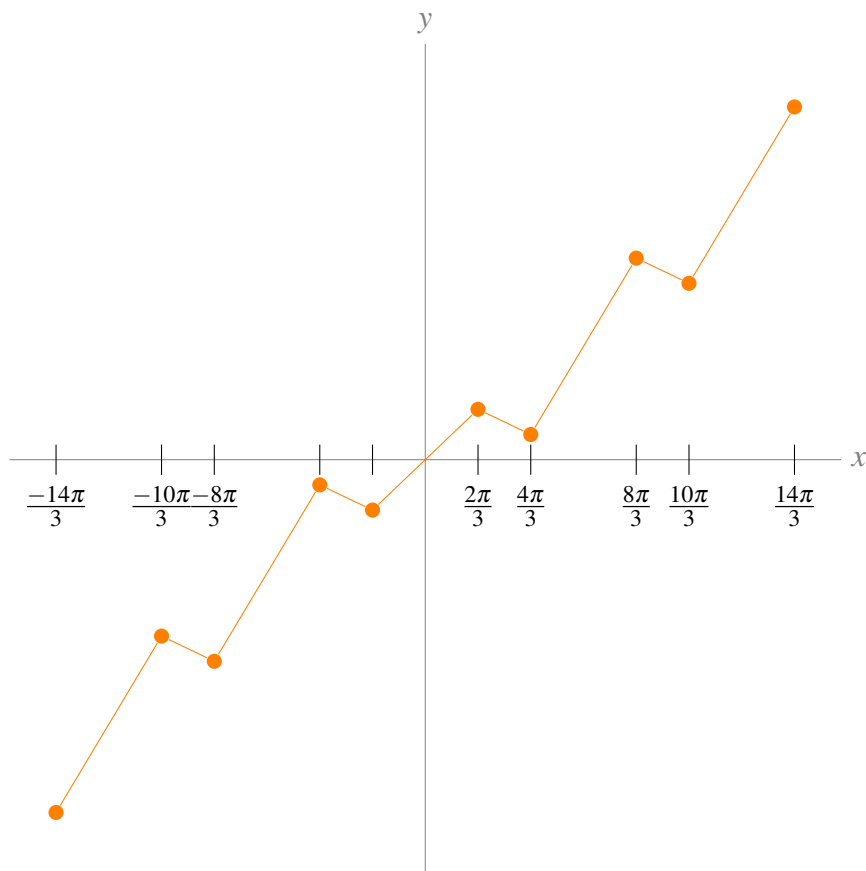

- Concavity:

$$f''(x) = -2\sin x$$

So, $f''(x)$ exists everywhere, and is zero for $x = \pi + \pi n$ for every integer n .

x	$(0, \pi)$	π	$(\pi, 2\pi)$	2π	$(2\pi, 3\pi)$	3π	$(3\pi, 4\pi)$
$f''(x)$	negative	0	positive	0	negative	0	positive
$f(x)$	concave down	IP	concave up	IP	concave down	IP	concave up

Using these values, and the odd symmetry of $f(x)$, we can refine our skeleton. The closed dots are local extrema, and the open dots are inflection points occurring at every integer multiple of π .

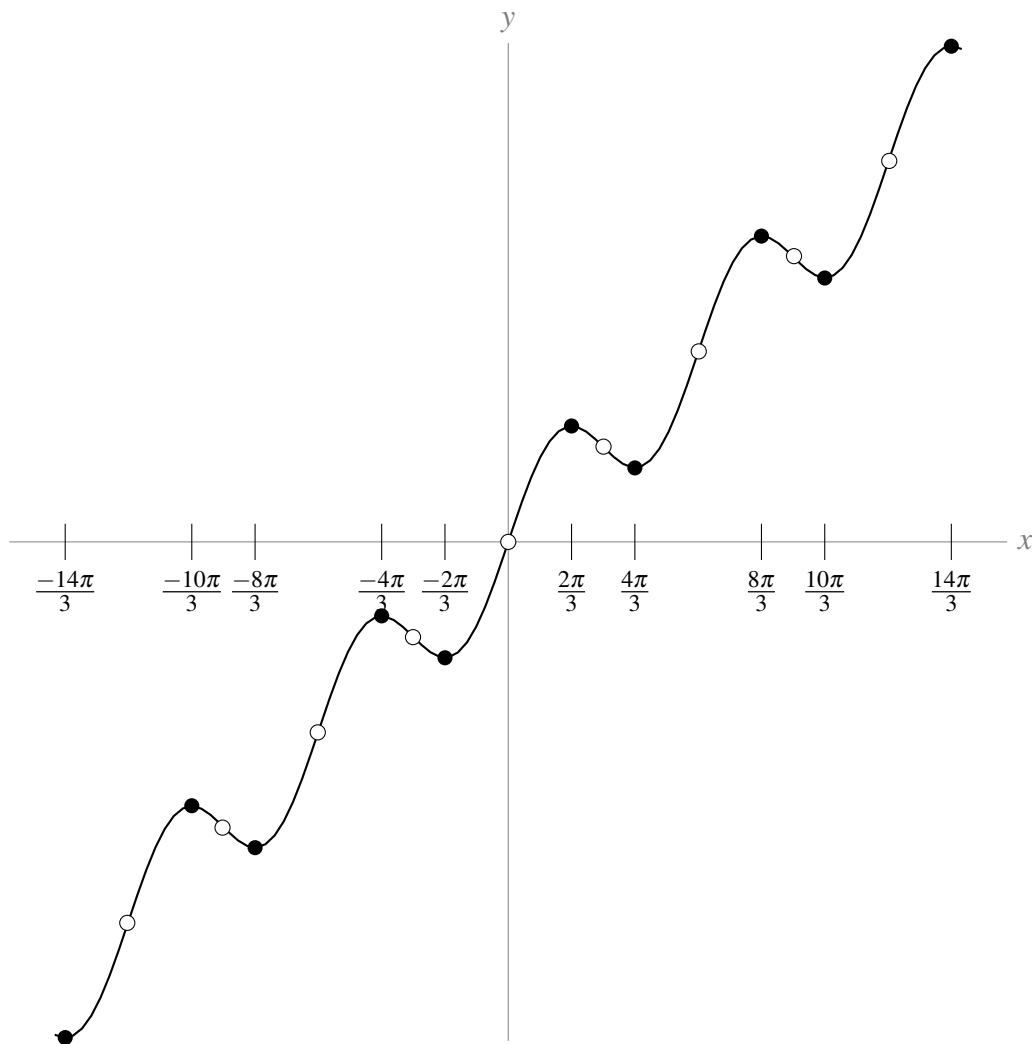

S-9: We first compute the derivatives $f'(x)$ and $f''(x)$.

$$f'(x) = 4 \cos x + 4 \sin 2x = 4 \cos x + 8 \sin x \cos x = 4 \cos x (1 + 2 \sin x)$$

$$f''(x) = -4 \sin x + 8 \cos 2x = -4 \sin x + 8 - 16 \sin^2 x = -4(4 \sin^2 x + \sin x - 2)$$

The graph has the following features.

- Symmetry: $f(x)$ is periodic of period 2π . We'll consider only $-\pi \leq x \leq \pi$. (Any interval of length 2π will do.)
- y-intercept: $f(0) = -2$
- Intervals of increase and decrease: $f'(x) = 0$ when $\cos x = 0$, i.e. $x = \pm \frac{\pi}{2}$, and when $\sin x = -\frac{1}{2}$, i.e. $x = -\frac{\pi}{6}, -\frac{5\pi}{6}$.

x	$(-\pi, -\frac{5\pi}{6})$	$(-\frac{5\pi}{6}, -\frac{\pi}{2})$	$(-\frac{\pi}{2}, -\frac{\pi}{6})$	$(-\frac{\pi}{6}, \frac{\pi}{2})$	$(\frac{\pi}{2}, \pi)$
$f'(x)$	negative	positive	negative	positive	negative
$f(x)$	decreasing	increasing	decreasing	increasing	decreasing

This tells us local maxima occur at $x = \pm \frac{\pi}{2}$ and local minima occur at $x = -\frac{5\pi}{6}$ and $x = -\frac{\pi}{6}$.

Here is a table giving the value of f at each of its critical points.

x	$-\frac{5\pi}{6}$	$-\frac{\pi}{2}$	$-\frac{\pi}{6}$	$\frac{\pi}{2}$
$\sin x$	$-\frac{1}{2}$	-1	$-\frac{1}{2}$	1
$\cos 2x$	$\frac{1}{2}$	-1	$\frac{1}{2}$	-1
$f(x)$	-3	-2	-3	6

From here, we can graph a skeleton of $f(x)$:

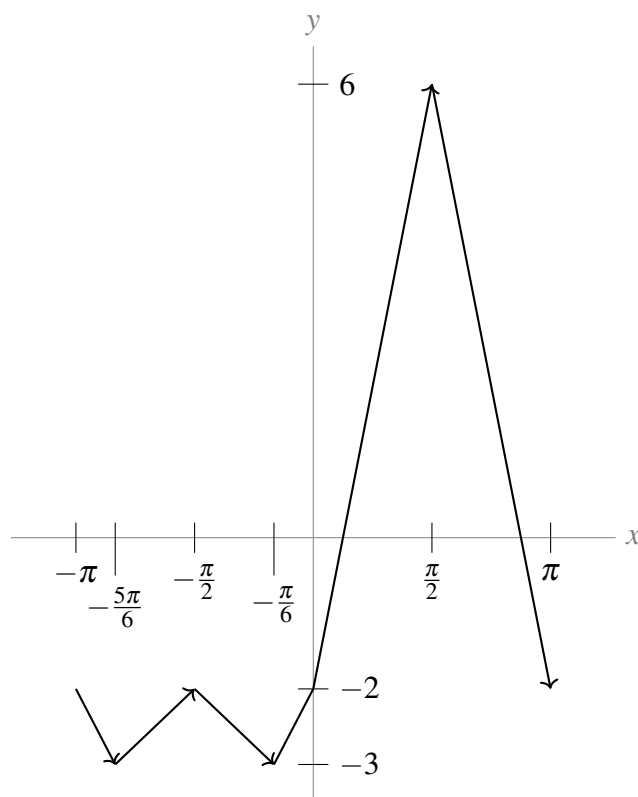

- Concavity: To find the points where $f''(x) = 0$, set $y = \sin x$, so $f''(x) = -4(4y^2 + y - 2)$. Then we really need to solve

$$4y^2 + y - 2 = 0$$

which gives us

$$y = \frac{-1 \pm \sqrt{33}}{8}$$

These two y -values map to the following two x -values, which we'll name a and b for convenience:

$$a = \arcsin\left(\frac{-1 + \sqrt{33}}{8}\right) \approx 0.635$$

$$b = \arcsin\left(\frac{-1 - \sqrt{33}}{8}\right) \approx -1.003$$

However, these are not the only values of x in $[-\pi, \pi]$ with $\sin x = \frac{-1 \pm \sqrt{33}}{8}$. The analysis above misses the others because the arcsine function only returns numbers in the range $[-\frac{\pi}{2}, \frac{\pi}{2}]$. The graph below shows that there should be other values of x with $\sin x = \frac{-1 \pm \sqrt{33}}{8}$, and hence $f''(x) = 0$.

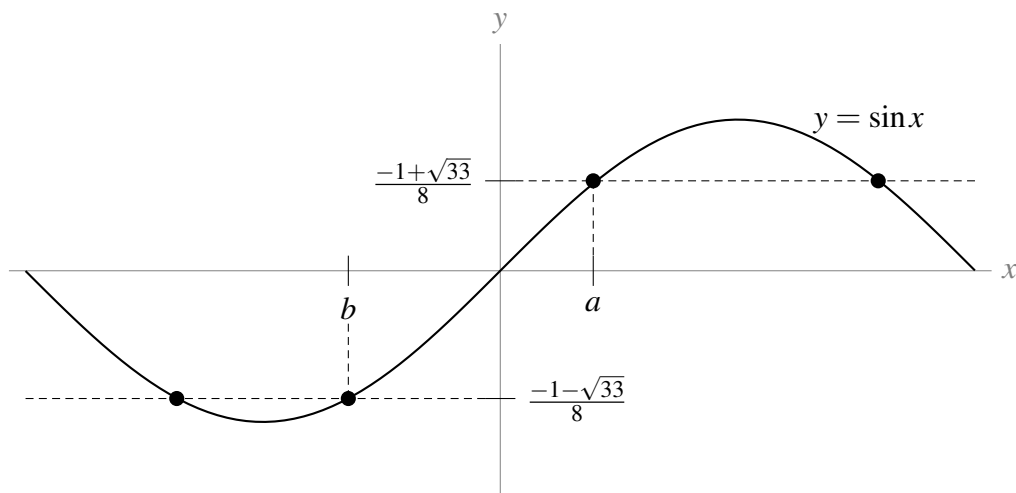

We can recover the other solutions in $[-\pi, \pi]$ by recalling that

$$\sin(x) = \sin(\pi - x).$$

So, if we choose $x = \arcsin\left(\frac{-1 + \sqrt{33}}{8}\right) \approx 0.635$ to make $\sin(x) = \frac{-1 + \sqrt{33}}{8}$ so that $f''(x) = 0$, then setting

$$x = \pi - a = \pi - \arcsin\left(\frac{-1 + \sqrt{33}}{8}\right) \approx 2.507$$

will also give us $\sin(x) = \frac{-1 + \sqrt{33}}{8}$ and $f''(x) = 0$. Similarly, setting

$$x = \pi - b = \pi - \arcsin\left(\frac{-1 - \sqrt{33}}{8}\right) \approx 4.145$$

would give us $f''(x) = 0$. However, this value is outside $[-\pi, \pi]$. To find another solution inside $[-\pi, \pi]$ we use the identity

$$\sin(x) = \sin(-\pi - x)$$

(which we can obtain from the identity we used above and the fact that $\sin(\theta) = \sin(\theta \pm 2\pi)$ for any angle θ). Using this, we can show that

$$x = -\pi - b = -\pi - \arcsin\left(\frac{-1 - \sqrt{33}}{8}\right) \approx -2.139$$

also gives $f''(x) = 0$.

So, all together, $f''(x) = 0$ when $x = -\pi - b$, $x = b$, $x = a$, and $x = \pi - a$.

Now, we should compute the sign of $f''(x)$ while x is between $-\pi$ and π . Recall that, if $y = \sin x$, then $f''(x) = -4(4y^2 + y - 2)$. So, in terms of y , f'' is a parabola pointing down,

with intercepts $y = \frac{-1 \pm \sqrt{33}}{8}$. Then f'' is positive when y is in the interval $\left(\frac{-1 - \sqrt{33}}{8}, \frac{-1 + \sqrt{33}}{8}\right)$, and f'' is negative otherwise. From the graph of sine, we see that y is between $\frac{-1 - \sqrt{33}}{8}$ and $\frac{-1 + \sqrt{33}}{8}$ precisely on the intervals $(-\pi, -\pi - b)$, (b, a) , and $(\pi - a, \pi)$.

Therefore, $f(x)$ is concave up on the intervals $(-\pi, -\pi - b)$, (b, a) , and $(\pi - a, \pi)$, and $f(x)$ is concave down on the intervals $(-\pi - b, b)$ and $(a, \pi - a)$. So, the inflection points of f occur at $x = -\pi - b$, $x = b$, $x = a$, and $x = \pi - a$.

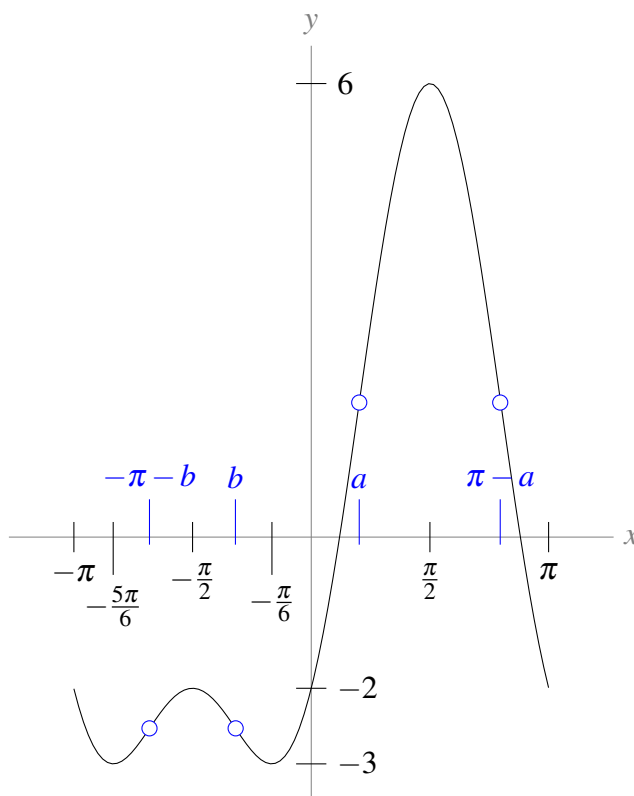

To find the maximum and minimum values of $f(x)$ on $[0, \pi]$, we compare the values of $f(x)$ at its critical points in this interval (only $x = \frac{\pi}{2}$) with the values of $f(x)$ at its endpoints $x = 0$, $x = \pi$.

Since $f(0) = f(\pi) = -2$, the minimum value of f on $[0, \pi]$ is -2 , achieved at $x = 0, \pi$ and the maximum value of f on $[0, \pi]$ is 6 , achieved at $x = \frac{\pi}{2}$.

S-10: Let $f(x) = \sqrt[3]{\frac{x+1}{x^2}}$.

- Asymptotes: Since $\lim_{x \rightarrow 0} f(x) = \infty$, $f(x)$ has a vertical asymptote at $x = 0$ where the curve reaches steeply upward from both the left and the right.

$\lim_{x \rightarrow \pm\infty} f(x) = 0$, so $y = 0$ is a horizontal asymptote for $x \rightarrow \pm\infty$.

- Intercepts: $f(-1) = 0$.

- Intervals of increase and decrease:

$$f'(x) = \frac{-(x+2)}{3x^{5/3}(x+1)^{2/3}}$$

There is a singular point at $x = -1$ and a critical point at $x = -2$, in addition to a discontinuity at $x = 0$. Note that $(x+1)^{2/3} = (\sqrt[3]{x+1})^2$, which is never negative. Note also that $\lim_{x \rightarrow -1} f'(x) = \infty$, so $f(x)$ has a vertical tangent line at $x = -1$.

x	$(-\infty, -2)$	-2	$(-2, -1)$	-1	$(-1, 0)$	0	$(0, \infty)$
$f'(x)$	negative	0	positive	DNE	positive	DNE	negative
$f(x)$	decreasing	l. min	increasing	vertical	increasing	VA	decreasing

This gives us enough information to sketch a skeleton of the curve.

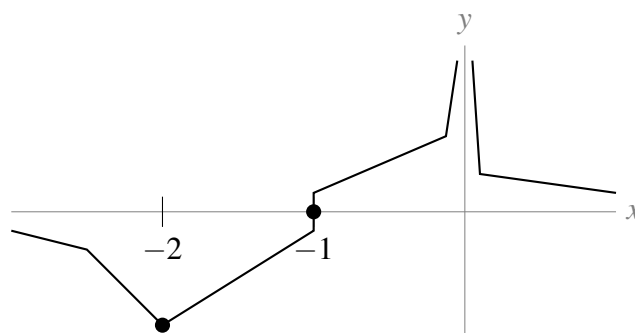

- Concavity:

$$f''(x) = \frac{4x^2 + 16x + 10}{9x^{8/3}(x+1)^{5/3}}$$

We still have a discontinuity at $x = 0$, and $f''(x)$ does not exist at $x = -1$. The second derivative is zero when $4x^2 + 16x + 10 = 0$. Using the quadratic formula, we find this occurs when $x = -2 \pm \sqrt{1.5} \approx -0.8, -3.2$. Note $x^{8/3} = (\sqrt[3]{x})^8$ is never negative.

x	$(-\infty, -2 - \sqrt{1.5})$	$-2 - \sqrt{1.5}$	$(-2 - \sqrt{1.5}, -1)$	-1
$f''(x)$	negative	0	positive	DNE
$f(x)$	concave down	IP	concave up	IP

x	$(-1, -2 + \sqrt{1.5})$	$-2 + \sqrt{1.5}$	$(-2 + \sqrt{1.5}, 0)$	$(0, \infty)$
$f''(x)$	negative	0	positive	positive
$f(x)$	concave down	IP	concave up	concave up

Now, we can refine our skeleton. The closed dot is the local minimum, and the open dots are inflection points.

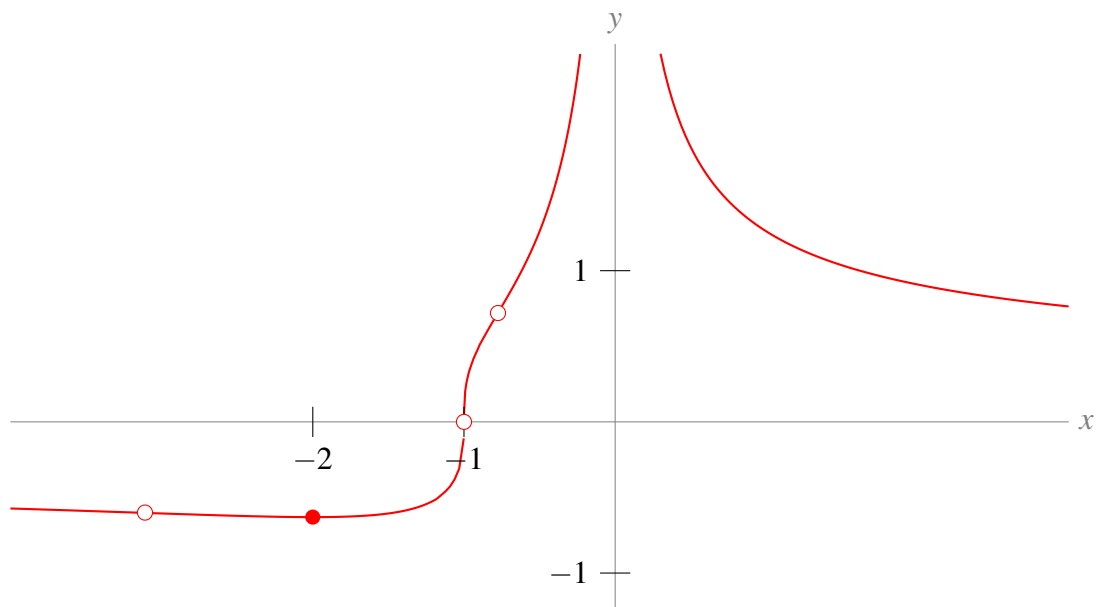

S-11: The parts of the question are just scaffolding to lead you through sketching the curve. Their answers are given explicitly, in an organized manner, in the “answers” section. In this solution, they are scattered throughout.

- Asymptotes:

Since the function has a derivative at every real number, the function is continuous for every real number, so it has no vertical asymptotes. In the problem statement, you are told $\lim_{x \rightarrow \infty} f(x) = 0$, so $y = 0$ is a horizontal asymptote as x goes to infinity. It remains to evaluate $\lim_{x \rightarrow -\infty} f(x)$. Let’s consider the limit of $f'(x)$ instead. Recall K is a positive constant.

$$\begin{aligned}\lim_{x \rightarrow -\infty} e^{-x} &= \lim_{x \rightarrow \infty} e^x = \infty \\ \lim_{x \rightarrow -\infty} K(2x - x^2) &= -\infty\end{aligned}$$

So,

$$\lim_{x \rightarrow -\infty} K(2x - x^2)e^{-x} = -\infty$$

That is, as x becomes a hugely negative number, $f'(x)$ also becomes a hugely negative number. As we move left along the x -axis, $f(x)$ is decreasing with a steeper and steeper slope, as in the sketch below. That means $\lim_{x \rightarrow -\infty} f(x) = \infty$.

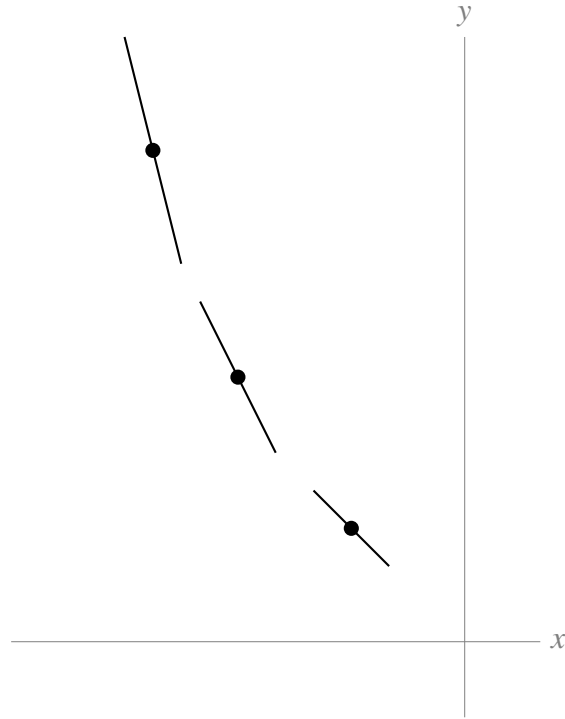

Sketch: various tangent lines to $f(x)$, their slopes getting more strongly negative as x gets more strongly negative.

- Intervals of increase and decrease:

We are given $f'(x)$ (although we don't know $f(x)$):

$$f'(x) = Kx(2-x)e^{-x}$$

The critical points of $f(x)$ are $x = 0$ and $x = 2$, and there are no singular points. Recall e^{-x} is always positive, and K is a positive constant.

x	$(-\infty, 0)$	0	$(0, 2)$	2	$(2, \infty)$
$f'(x)$	negative	0	positive	0	negative
$f(x)$	decreasing	local min	increasing	local max	decreasing

So, $f(0) = 0$ is a local minimum, and $f(2) = 2$ is a local maximum.

Looking ahead to part (d), we have a skeleton of the curve.

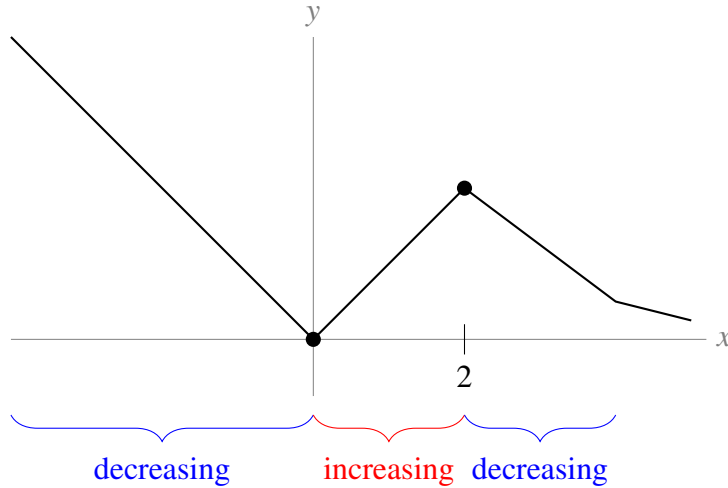

• Concavity:

Since we're given $f'(x)$, we can find $f''(x)$.

$$\begin{aligned}
 f''(x) &= K(2 - 2x - 2x + x^2)e^{-x} \\
 &= K(2 - 4x + x^2)e^{-x} \\
 &= K(x - 2 - \sqrt{2})(x - 2 + \sqrt{2})e^{-x}
 \end{aligned}$$

where the last line can be found using the quadratic equation. So, $f''(x) = 0$ for $x = 2 \pm \sqrt{2}$, and $f''(x)$ exists everywhere.

x	$(-\infty, 2 - \sqrt{2})$	$2 - \sqrt{2}$	$(2 - \sqrt{2}, 2 + \sqrt{2})$	$2 + \sqrt{2}$	$(2 + \sqrt{2}, \infty)$
$f'(x)$	positive	0	negative	0	positive
$f(x)$	concave up	IP	concave down	IP	concave up

Now, we can add concavity to our sketch.

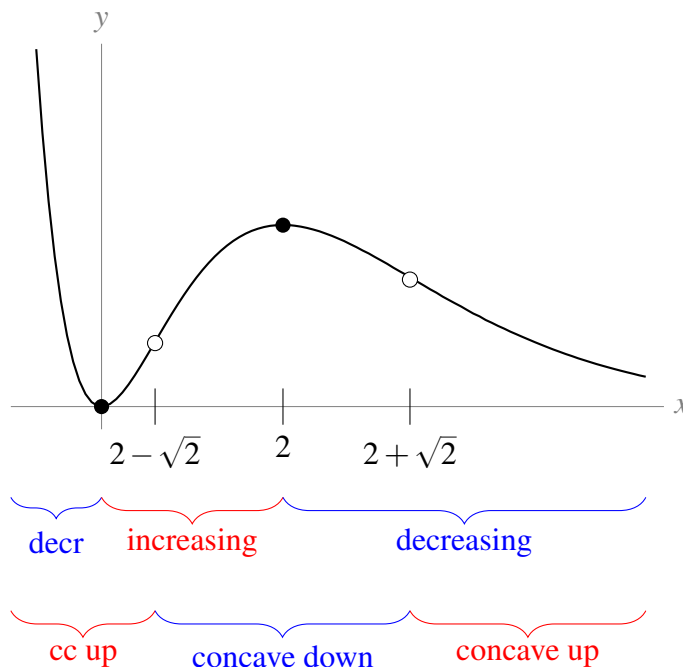

S-12: (a) You should be familiar with the graph of $y = e^x$. You can construct the graph of $y = e^{-x}$ just by reflecting the graph of $y = e^x$ across the y -axis. To see why this is the case, imagine swapping each value of x with its negative: for example, swapping the point at $x = -1$ with the point at $x = 1$, etc. Alternatively, you can graph $y = f(x) = e^{-x}$, $x \geq 0$, using the methods of this section: at $x = 0$, $y = f(0) = 1$; as x increases, $y = f(x) = e^{-x}$ decreases, with no local extrema; and as $x \rightarrow +\infty$, $y = f(x) \rightarrow 0$.

There are no inflection points or extrema, except the endpoint $(0, 1)$.

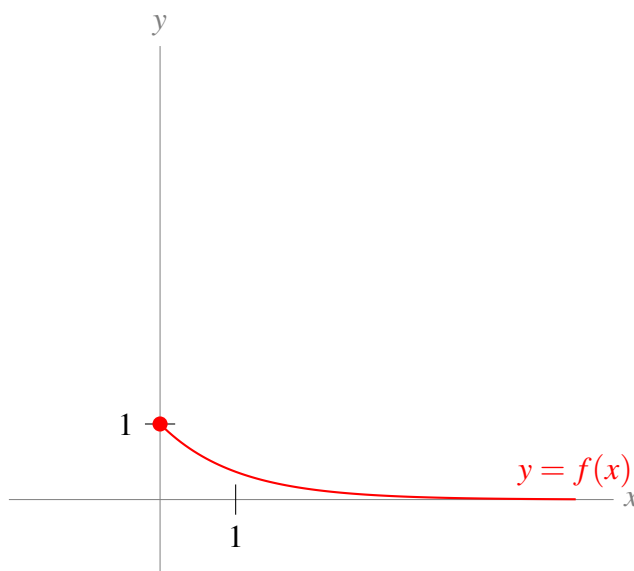

(b)

Recall that, to graph the inverse of a function, we reflect the original function across the line $y = x$. To see why this is true, consider the following. By definition, the inverse function g of f is obtained by solving $y = f(x)$ for x as a function of y . So, for any pair of numbers x and y , we have

$$f(x) = y \text{ if and only if } g(y) = x$$

That is, g is the function that swaps the input and output of f . Now the point (x, y) lies on the graph of f if and only if $y = f(x)$. Similarly, the point (X, Y) lies on the graph of g if and only if $Y = g(X)$. Choosing $Y = x$ and $X = y$, we see that the point $(X, Y) = (y, x)$ lies on the graph of g if and only if $x = g(y)$, which in turn is the case if and only if $y = f(x)$. So

$$(y, x) \text{ is on the graph of } g \text{ if and only if } (x, y) \text{ is on the graph of } f.$$

To get from the point (x, y) to the point (y, x) we have to exchange $x \leftrightarrow y$, which we can do by reflecting over the line $y = x$. Thus we can construct the graph of g by reflecting the curve $y = f(x)$ over the line $y = x$.

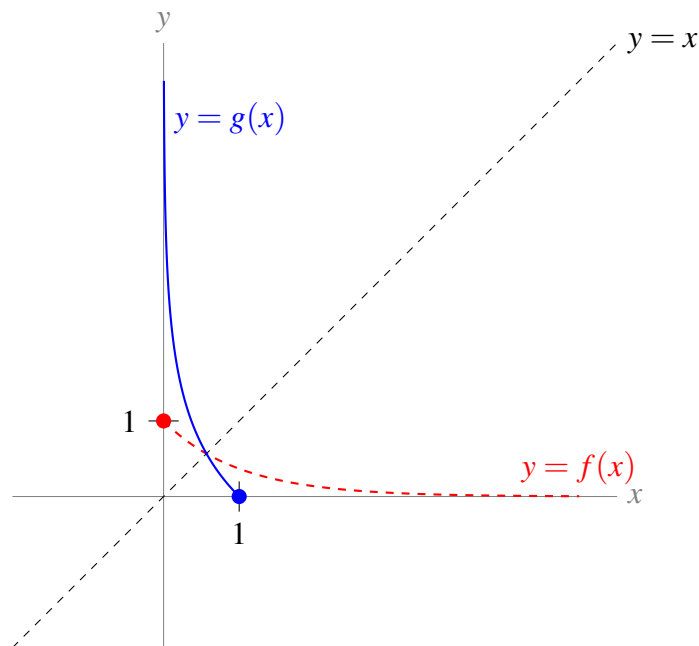

(c) The domain of g is the range of f , which is $(0, 1]$. The range of g is the domain of f , which is $[0, \infty)$.

(d) Since g and f are inverses,

$$g(f(x)) = x$$

Using the chain rule,

$$g'(f(x)) \cdot f'(x) = 1$$

Since $f'(x) = -e^{-x} = -f(x)$:

$$g'(f(x)) \cdot f(x) = -1$$

We plug in $f(x) = \frac{1}{2}$.

$$g'\left(\frac{1}{2}\right) \cdot \frac{1}{2} = -1$$

$$g'\left(\frac{1}{2}\right) = -2$$

S-13: (a) First, we differentiate.

$$f(x) = x^5 - x \quad f'(x) = 5x^4 - 1 \quad f''(x) = 20x^3$$

The function and its first derivative tells us the following:

- $\lim_{x \rightarrow \infty} f(x) = \infty$, $\lim_{x \rightarrow -\infty} f(x) = -\infty$
- $f'(x) > 0$ (i.e. f is increasing) for $|x| > \frac{1}{\sqrt[4]{5}}$

- $f'(x) = 0$ (i.e. f has critical points) for $x = \pm \frac{1}{\sqrt[4]{5}} \approx \pm 0.67$

- $f'(x) < 0$ (i.e. f is decreasing) for $|x| < \frac{1}{\sqrt[4]{5}}$

- $f\left(\pm \frac{1}{\sqrt[4]{5}}\right) = \mp \frac{4}{5\sqrt[4]{5}} \approx \mp 0.53$

This gives us a first idea of the shape of the graph.

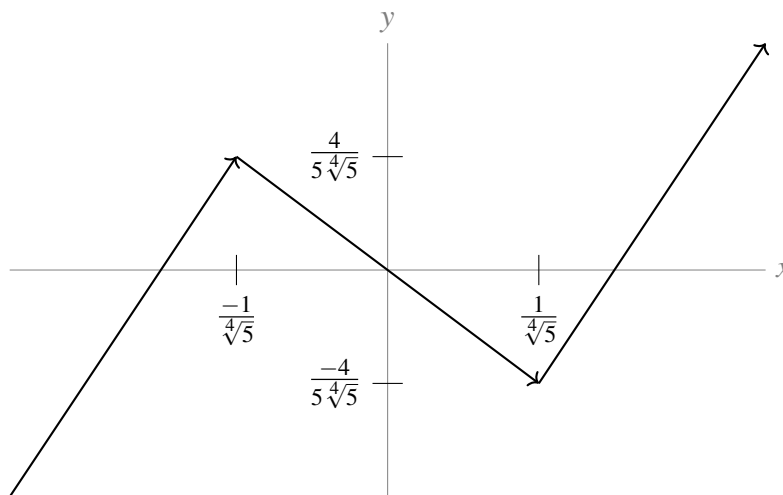

We refine this skeleton using information from the second derivative.

- $f''(x) > 0$ (i.e. f is concave up) for $x > 0$,
- $f''(x) = 0$ (i.e. f has an inflection point) for $x = 0$, and
- $f''(x) < 0$ (i.e. f is concave down) for $x < 0$

Thus

- f has no asymptotes
- f has a local maximum at $x = -\frac{1}{\sqrt[4]{5}}$ and a local minimum at $x = \frac{1}{\sqrt[4]{5}}$
- f has an inflection point at $x = 0$
- f is concave down for $x < 0$ and concave up for $x > 0$

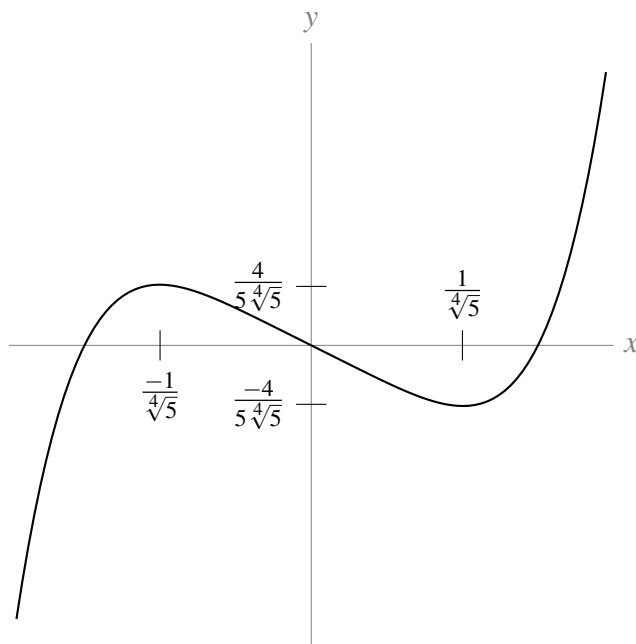

(b) The function $x^5 - x + k$ has a root at $x = x_0$ if and only if $x^5 - x = -k$ at $x = x_0$. So the number of distinct real roots of $x^5 - x + k$ is the number of times the curve $y = x^5 - x$ crosses the horizontal line $y = -k$. The local maximum of $x^5 - x$ (when $x = -\frac{1}{\sqrt[4]{5}}$) is $\frac{4}{5\sqrt[4]{5}}$, and the local minimum of $x^5 - x$ (when $x = \frac{1}{\sqrt[4]{5}}$) is $-\frac{4}{5\sqrt[4]{5}}$. So, looking at the graph of $x^5 - x$ above, we see that the number of distinct real roots of $x^5 - x + k$ is

- 1 when $|k| > \frac{4}{5\sqrt[4]{5}}$
- 2 when $|k| = \frac{4}{5\sqrt[4]{5}}$
- 3 when $|k| < \frac{4}{5\sqrt[4]{5}}$

S-14:

(a) You might not be familiar with hyperbolic sine and cosine, but you don't need to be. We can graph them using the same methods as the other curves in this section. The derivatives are given to us:

$$\begin{aligned} \frac{d}{dx} \{\sinh x\} &= \cosh x = \frac{e^x + e^{-x}}{2} & \frac{d}{dx} \{\cosh x\} &= \sinh x = \frac{e^x - e^{-x}}{2} \\ \left(\frac{d}{dx}\right)^2 \{\sinh x\} &= \sinh x = \frac{e^x - e^{-x}}{2} & \left(\frac{d}{dx}\right)^2 \{\cosh x\} &= \cosh x = \frac{e^x + e^{-x}}{2} \end{aligned}$$

Observe that:

- $\sinh(x)$ has a derivative that is always positive, so $\sinh(x)$ is always increasing. The second derivative of $\sinh(x)$ is negative to the left of $x = 0$ and positive to the right of $x = 0$, so $\sinh(x)$ is concave down to the left of the y -axis and concave up to its right, with an inflection point at $x = 0$.

- $\cosh(x)$ has a derivative that is positive when $x > 0$ and negative when $x < 0$. The second derivative of $\cosh(x)$ is always positive, so it is always concave up.

- $\cosh(0) = 1$ and $\sinh(0) = 0$.

- $\lim_{x \rightarrow \infty} \sinh x = \lim_{x \rightarrow \infty} \cosh x = \lim_{x \rightarrow \infty} \frac{e^x}{2} = \infty$, since $\lim_{x \rightarrow \infty} e^{-x} = 0$

- $\lim_{x \rightarrow -\infty} \sinh x = \lim_{x \rightarrow -\infty} \left(\frac{e^x}{2} - \frac{e^{-x}}{2} \right) = \lim_{x \rightarrow \infty} \left(\frac{e^{-x}}{2} - \frac{e^x}{2} \right) = -\infty$ and

$$\lim_{x \rightarrow -\infty} \cosh x = \lim_{x \rightarrow -\infty} \left(\frac{e^x}{2} + \frac{e^{-x}}{2} \right) = \lim_{x \rightarrow \infty} \left(\frac{e^{-x}}{2} + \frac{e^x}{2} \right) = \infty$$

- $\cosh(x)$ is even, since $\cosh(-x) = \frac{e^{-x} + e^{-(-x)}}{2} = \frac{e^{-x} + e^x}{2} = \cosh(x)$, and

$$\sinh(x) \text{ is odd, since } \sinh(-x) = \frac{e^{-x} - e^{-(-x)}}{2} = \frac{e^{-x} - e^x}{2} = \frac{-(e^x - e^{-x})}{2} = -\sinh(x)$$

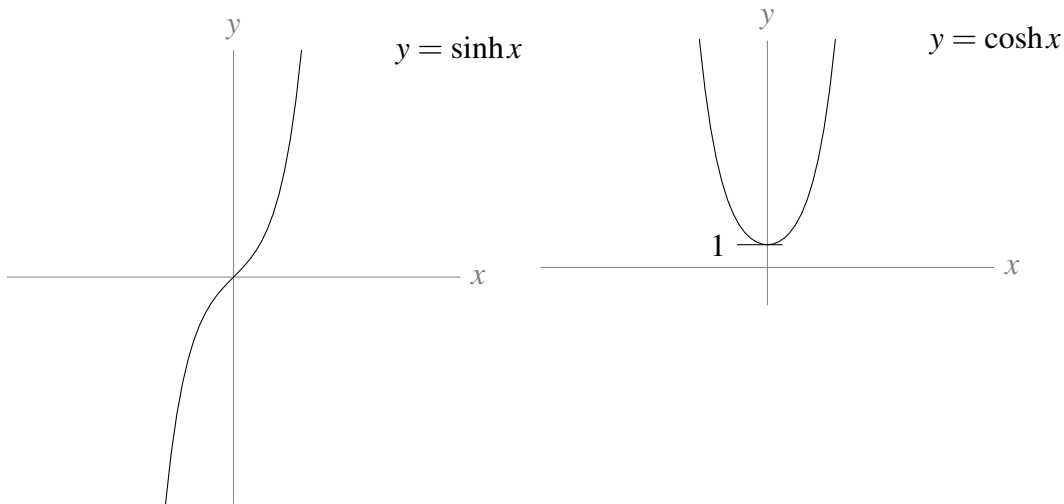

(b)

- As y runs over $(-\infty, \infty)$ the function $\sinh(y)$ takes every real value exactly once. So, for each $x \in (-\infty, \infty)$, define $\sinh^{-1}(x)$ to be the unique solution of $\sinh(y) = x$.

- As y runs over $[0, \infty)$ the function $\cosh(y)$ takes every real value in $[1, \infty)$ exactly once. In particular, the smallest value of $\cosh(y)$ is $\cosh(0) = 1$. So, for each $x \in [1, \infty)$, define $\cosh^{-1}(x)$ to be the unique $y \in [0, \infty)$ that obeys $\cosh(y) = x$.

To graph the inverse of a (one-to-one) function, we reflect the original function over the line $y = x$. Using this method to graph $y = \sinh^{-1}(x)$ is straightforward. To graph $y = \cosh^{-1}(x)$, we need to be careful of the domains: we are restricting $\cosh(x)$ to values of x in $[0, \infty)$. The graphs are

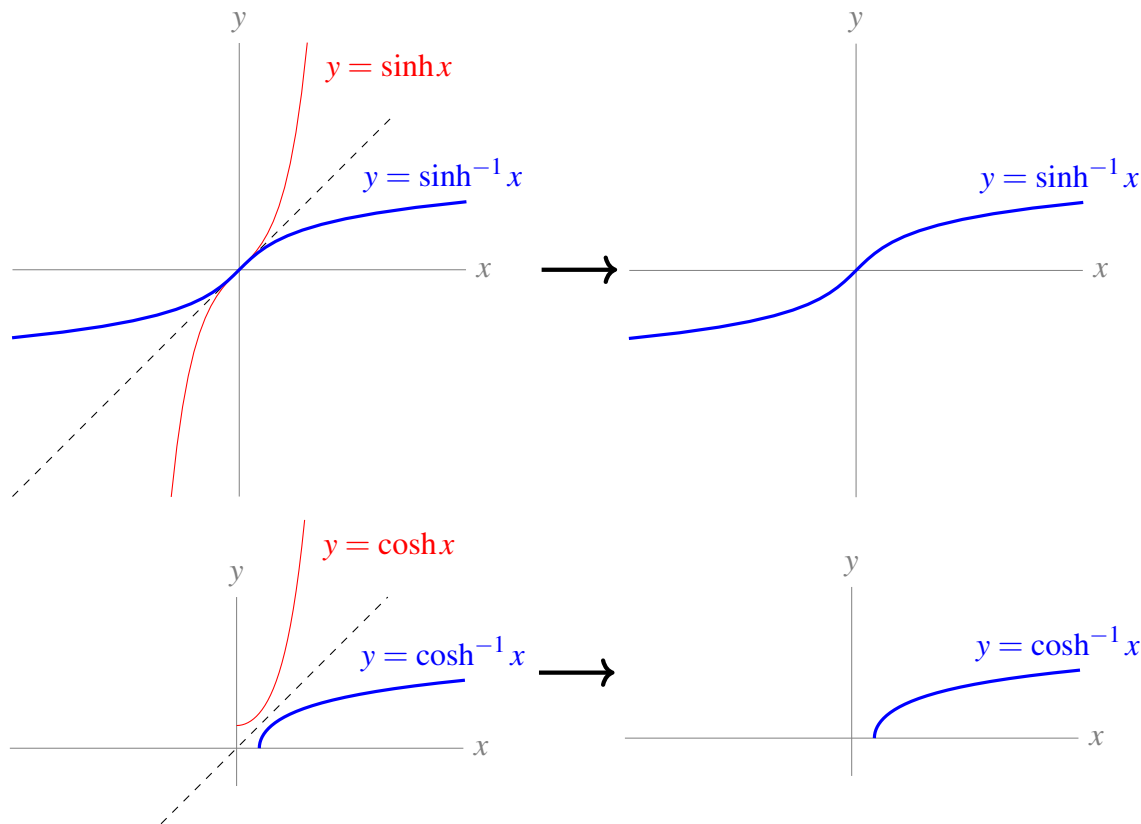

(c) Let $y(x) = \cosh^{-1}(x)$. Then, using the definition of \cosh^{-1} ,

$$\cosh y(x) = x$$

We differentiate with respect to x using the chain rule.

$$\begin{aligned} \frac{d}{dx} \{ \cosh y(x) \} &= \frac{d}{dx} \{ x \} \\ y'(x) \sinh y(x) &= 1 \end{aligned}$$

We solve for $y'(x)$.

$$y'(x) = \frac{1}{\sinh y(x)}$$

We want to have our answer in terms of x , not y . We know that $\cosh y = x$, so if we can convert hyperbolic sine into hyperbolic cosine, we can get rid of y . Our tool for this is the identity, given in the question statement, $\cosh^2(x) - \sinh^2(x) = 1$. This tells us $\sinh^2(y) = 1 - \cosh^2(y)$. Now we have to decide whether $\sinh(y)$ is the positive or negative square root of $1 - \cosh^2(y)$ in our context. Looking at the graph of $y(x) = \cosh^{-1}(x)$, we see $y'(x) > 0$. So we use the positive square root:

$$y'(x) = \frac{1}{\sqrt{\cosh^2 y(x) - 1}} = \frac{1}{\sqrt{x^2 - 1}}$$

Remark: $\frac{d}{dx} \{ \arccos(x) \} = \frac{-1}{\sqrt{1-x^2}}$, so again the hyperbolic trigonometric function has properties similar to (but not exactly the same as) its trigonometric counterpart.

Solutions to Exercises 8.1 — Jump to [TABLE OF CONTENTS](#)

S-1:

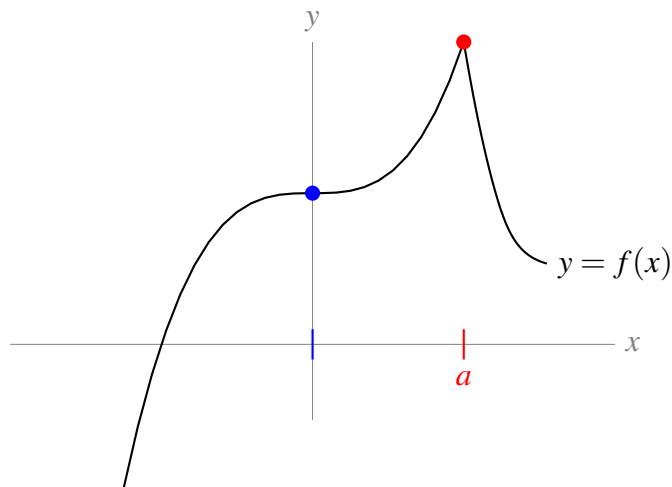

When $x = 0$, the curve $y = f(x)$ appears to have a flat tangent line, so the $x = 0$ is a critical point. However, it is not a local extremum: it is not true that $f(0) \geq f(x)$ for all x near 0, and it is not true that $f(0) \leq f(x)$ for all x near 0.

To the right of the x -axis, there is a spike where the derivative of $f(x)$ does not exist. The x -value corresponding to this spike (call it a) is a singular point, and $f(x)$ has a local maximum at $x = a$.

S-2:

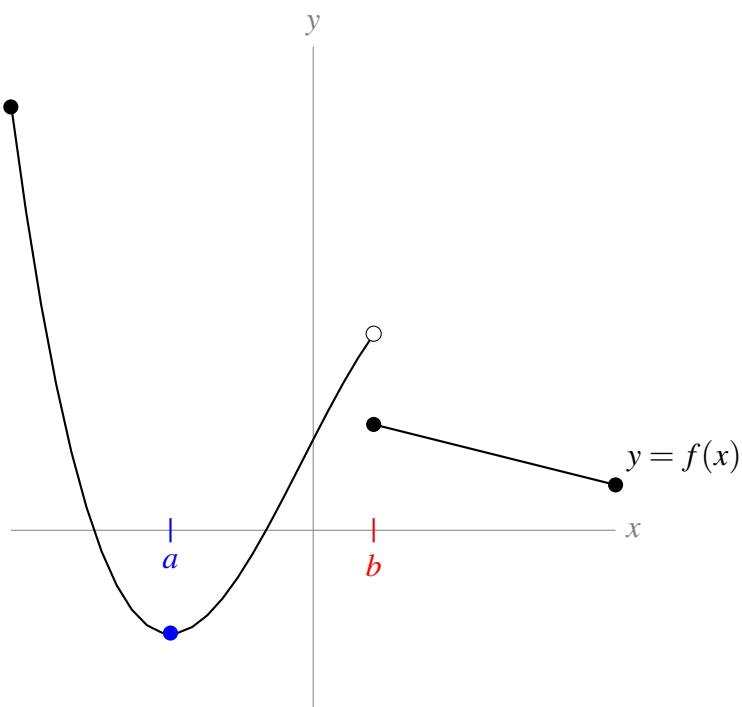

The x -coordinate corresponding to the blue dot (let's call it a) is a critical point, because the tangent

line to $f(x)$ at $x = a$ is horizontal. There is no lower point nearby, and actually no lower point on the whole interval shown, so $f(x)$ has both a local minimum and a global minimum at $x = a$.

If a function is not continuous at a point, then it is not differentiable at that point. So, the x -coordinate corresponding to the discontinuity (let's call it b) is a singular point. Values of $f(x)$ immediately to the right of b are lower, and values immediately to the left of b are higher, so $f(x)$ has no local (or global) extremum at $x = b$.

S-3: One possible answer is shown below.

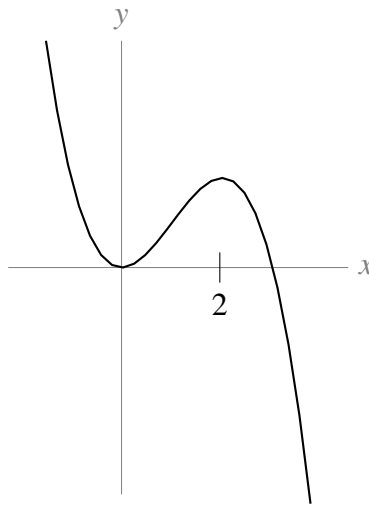

For every x in the red interval shown below, $f(2) \geq f(x)$, so $f(2)$ is a local maximum. However, the point marked with a blue dot shows that $f(x) > f(2)$ for some x , so $f(2)$ is not a global maximum.

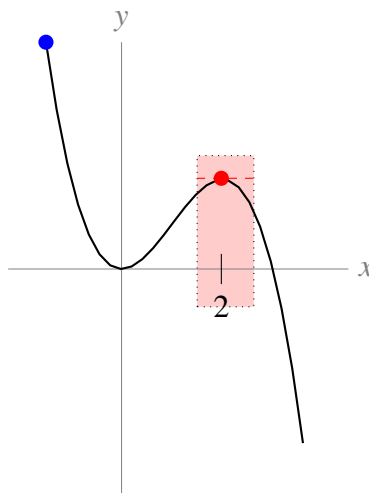

S-4: Critical points are those values of x for which $f'(x) = 0$, and singular points are those values

of x for which $f(x)$ is not differentiable. So, we ought to find $f'(x)$. Using the quotient rule,

$$\begin{aligned} f'(x) &= \frac{(1)(x^2 + 3) - (x - 1)(2x)}{(x^2 + 3)^2} \\ &= \frac{-x^2 + 2x + 3}{(x^2 + 3)^2} \\ &= -\frac{(x - 3)(x + 1)}{(x^2 + 3)^2} \end{aligned}$$

- (a) The derivative $f'(x)$ is zero when $x = 3$ and when $x = -1$, so those are the critical points.
- (b) The denominator of $f'(x)$ is never zero, so the derivative $f'(x)$ exists for all x and $f(x)$ has no singular points.
- (c) Theorem 8.1.3 tells us that local extrema of $f(x)$ can only occur at critical points and singular points. So, the possible points where extrema of $f(x)$ may exist are $x = 3$ and $x = -1$.

S-5:

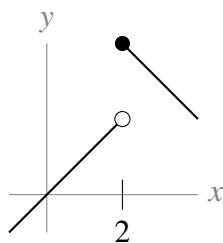

local max

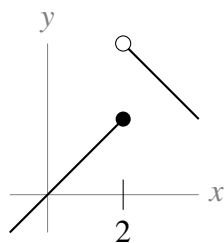

neither

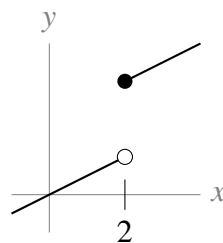

neither

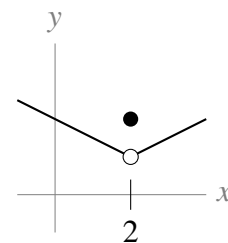

local max

For the first curve, the function's value at $x = 2$ (that is, the y -value of the solid dot) is higher than anything around it. So, it's a local maximum.

For the second curve, the function's value at $x = 2$ (that is, the y -value of the solid dot) is higher than everything to the left, but lower than values immediately to the right. (On the graph reproduced below, $f(x)$ is higher than everything in the red section, and lower than everything in the blue section.) So, it is neither a local max nor a local min.

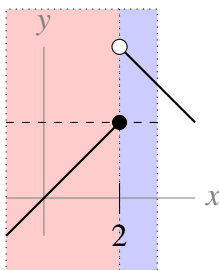

Similarly, for the third curve, $f(2)$ is lower than the values to the right of it, and higher than values to the left of it, so it is neither a local minimum nor a local maximum.

In the final curve, $f(2)$ (remember—this is the y -value of the solid dot) is higher than everything immediately to the left or right of it (for instance, over the interval marked in red below), so it is a

local maximum.

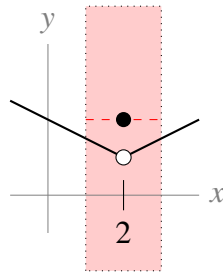

S-6: The question specifies that $x = 2$ must not be an endpoint. By Theorem 8.1.3, if $x = 2$ not a critical point, then it must be a singular point. That is, $f(x)$ is not differentiable at $x = 2$. Two possibilities are shown below, but there are infinitely many possible answers.

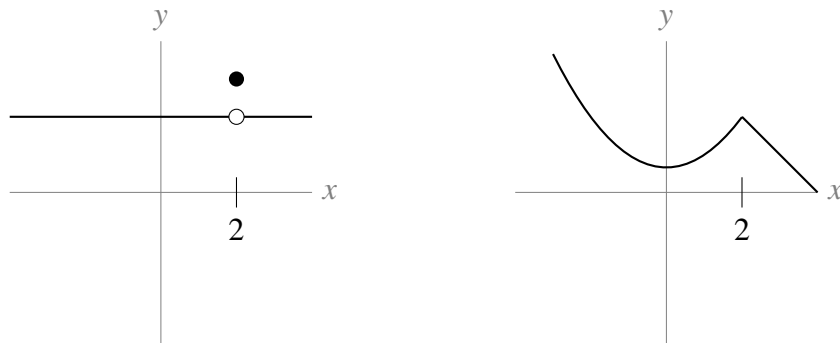

S-7: Critical points are those values of x for which $f'(x) = 0$, and singular points are those values of x for which $f(x)$ is not differentiable. So, we ought to find $f'(x)$. Since $f(x)$ has an absolute value sign, let's re-write it in a version that is friendlier to differentiation. Remember that $|X| = X$ when $X \geq 0$, and $|X| = -X$ when $X < 0$.

$$\begin{aligned}
 f(x) &= \sqrt{|(x-5)(x+7)|} \\
 &= \begin{cases} \sqrt{(x-5)(x+7)} & \text{if } (x-5)(x+7) \geq 0 \\ \sqrt{-(x-5)(x+7)} & \text{if } (x-5)(x+7) < 0 \end{cases}
 \end{aligned}$$

The product $(x-5)(x+7)$ is positive when $(x-5)$ and $(x+7)$ have the same sign, and negative when they have opposite signs, so

$$f(x) = \begin{cases} \sqrt{(x-5)(x+7)} & \text{if } x \in (-\infty, -7] \cup [5, \infty) \\ \sqrt{-(x-5)(x+7)} & \text{if } x \in (-7, 5) \end{cases}$$

Now, when $x \neq -7, 5$, we can differentiate, using the chain rule.

$$f'(x) = \begin{cases} \frac{\frac{d}{dx}\{(x-5)(x+7)\}}{2\sqrt{(x-5)(x+7)}} & \text{if } x \in (-\infty, -7) \cup (5, \infty) \\ \frac{\frac{d}{dx}\{-(x-5)(x+7)\}}{2\sqrt{-(x-5)(x+7)}} & \text{if } x \in (-7, 5) \\ ? & \text{if } x = -7, x = 5 \end{cases}$$

$$= \begin{cases} \frac{2x+2}{2\sqrt{(x-5)(x+7)}} & \text{if } x \in (-\infty, -7) \cup (5, \infty) \\ \frac{-2x-2}{2\sqrt{-(x-5)(x+7)}} & \text{if } x \in (-7, 5) \\ ? & \text{if } x = -7, x = 5 \end{cases}$$

We are tempted to say that the derivative doesn't exist when $x = -7$ and $x = 5$, but be careful— we don't actually know that yet. The formulas we have for the $f'(x)$ are only good when x is *not* -7 or 5 .

The middle formula $\frac{-2x-2}{2\sqrt{-(x-5)(x+7)}}$ tells us $x = -1$ is a critical point: when $x = -1$, $f'(x)$ is given by the middle line, and it is 0. Note that $x = -1$ also makes the top formula 0, but $f'(-1)$ is not given by the top formula, so that doesn't matter.

What we've concluded so far is that $x = -1$ is a critical point of $f(x)$, and $f(x)$ has no other critical points or singular points when $x \neq -7, 5$. It remains to figure out what's going on at -7 and 5 . One way to do this is to use the definition of the derivative to figure out what $f'(-7)$ and $f'(5)$ are, if they exist. This is somewhat laborious. Let's look for a better way.

- First, let's notice that $f(x)$ is defined for all values of x , thanks to that handy absolute value sign.
- Next, notice $f(x) \geq 0$ for all x , since square roots never give a negative value.
- Then if there is some value of x that gives $f(x) = 0$, that x gives a global minimum, and therefore a local minimum.
- $f(x) = 0$ exactly when $(x-5)(x+7) = 0$, which occurs at $x = -7$ and $x = 5$
- Therefore, $f(x)$ has global and local minima at $x = -7$ and $x = 5$
- So, $x = -7$ and $x = 5$ are critical points or singular points by Theorem 8.1.3.

So, all together:

$x = -1$ is a critical point, and $x = -7$ and $x = 5$ are critical points or singular points (but we don't know which).

Remark: if you would like a review of how to use the definition of the derivative, below we show that $f(x)$ is not differentiable at $x = -7$. (In fact, $x = -7$ and $x = 5$ are both singular points.)

$$\begin{aligned}
 f'(-7) &= \lim_{h \rightarrow 0} \frac{f(-7+h) - f(-7)}{h} \\
 &= \lim_{h \rightarrow 0} \frac{\sqrt{|(-13+h)(h)|} - \sqrt{|0|}}{h} \\
 &= \lim_{h \rightarrow 0} \frac{\sqrt{|(-13+h)(h)|}}{h}
 \end{aligned}$$

Let's first consider the case $h > 0$.

$$\begin{aligned}
 \lim_{h \rightarrow 0^+} \frac{\sqrt{|(-13+h)(h)|}}{h} &= \lim_{h \rightarrow 0^+} \frac{\sqrt{(13-h)(h)}}{h} \\
 &= \lim_{h \rightarrow 0^+} \frac{\sqrt{13h-h^2}}{\sqrt{h^2}} \\
 &= \lim_{h \rightarrow 0^+} \sqrt{\frac{13h-h^2}{h^2}} \\
 &= \lim_{h \rightarrow 0^+} \sqrt{\frac{13}{h} - 1} \\
 &= \infty
 \end{aligned}$$

Since one side of the limit doesn't exist,

$$\lim_{h \rightarrow 0} \frac{f(-7+h) - f(-7)}{h} = DNE$$

so $f'(x)$ is not differentiable at $x = -7$. Therefore, $x = -7$ is a singular point.

S-8: For any real number c , c is in the domain of $f(x)$ and $f'(c)$ exists and is equal to zero. So, following Definition 8.1.5, every real number is a critical point of $f(x)$, and $f(x)$ has no singular points.

For every number c , let $a = c - 1$ and $b = c + 1$, so $a < c < b$. Then $f(x)$ is defined for every x in the interval $[a, b]$, and $f(x) = f(c)$ for every $a \leq x \leq b$. That means $f(x) \leq f(c)$ and $f(x) \geq f(c)$. So, comparing with Definition 8.1.2, we see that $f(x)$ has a global and local maximum AND minimum at every real number $x = c$.

Solutions to Exercises 8.2 — Jump to [TABLE OF CONTENTS](#)

S-1: Two examples are given below, but many are possible.

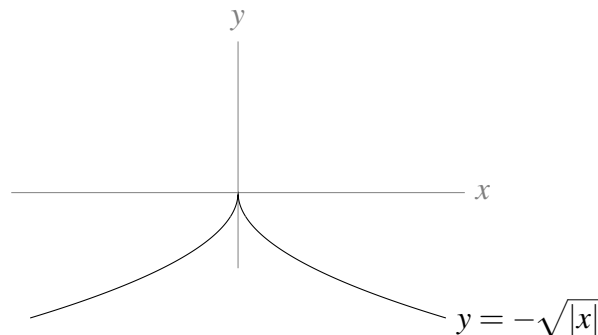
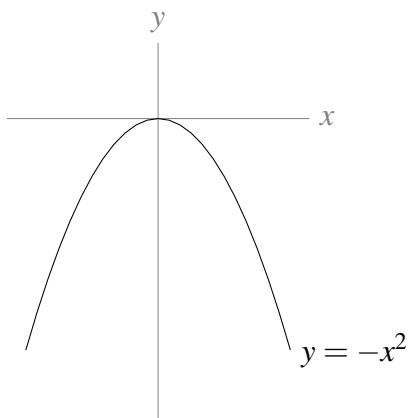

If $f(x) = -x^2$ or $f(x) = -\sqrt{|x|}$, then $f(x)$ has a global maximum at $x = 0$. Since $f(x)$ keeps getting more and more strongly negative as x gets farther and farther from 0, $f(x)$ has no global minimum.

S-2: Two examples are given below, but many are possible.

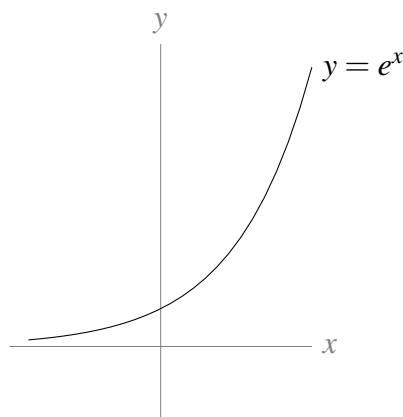

If $f(x) = e^x$, then $f(x) > 0$ for all x . As we move left along the x -axis, $f(x)$ gets smaller and smaller, approaching 0 but never reaching it. Since $f(x)$ gets smaller and smaller as we move left, there is no global minimum. Likewise, $f(x)$ increases more and more as we move right, so there is no maximum.

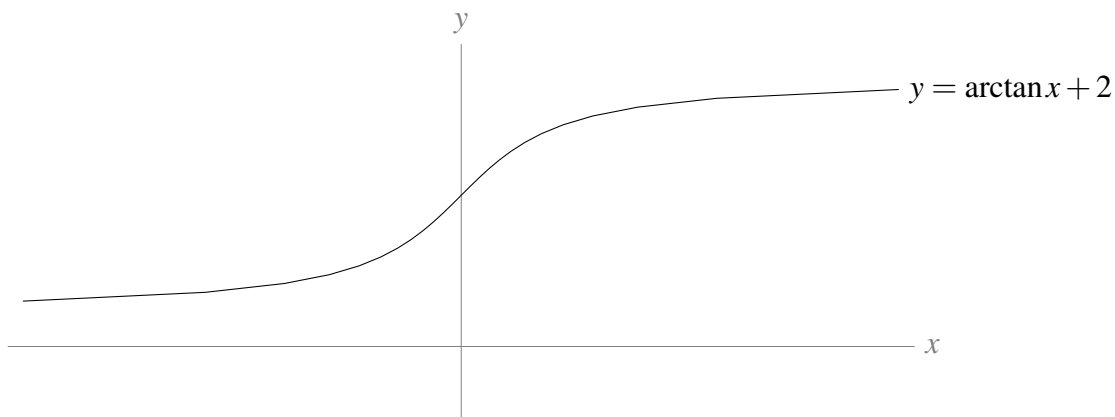

If $f(x) = \arctan(x) + 2$, then $f(x) > (-\frac{\pi}{2}) + 2 > 0$ for all x .

As we move left along the x -axis, $f(x)$ gets smaller and smaller, approaching $(-\frac{\pi}{2} + 2)$ but never reaching it. Since $f(x)$ gets smaller and smaller as we move left, there is no global minimum.

Likewise, as we move right along the x -axis, $f(x)$ gets bigger and bigger, approaching $(\frac{\pi}{2} + 2)$ but never reaching it. Since $f(x)$ gets bigger and bigger as we move right, there is no global maximum.

S-3: Since $f(5)$ is a global minimum, $f(5) \leq f(x)$ for all x , and so in particular $f(5) \leq f(-5)$. Similarly, $f(-5) \leq f(x)$ for all x , so in particular $f(-5) \leq f(5)$. Since $f(-5) \leq f(5)$ AND $f(5) \leq f(-5)$, it must be true that $f(-5) = f(5)$.

A sketch of one such graph is below.

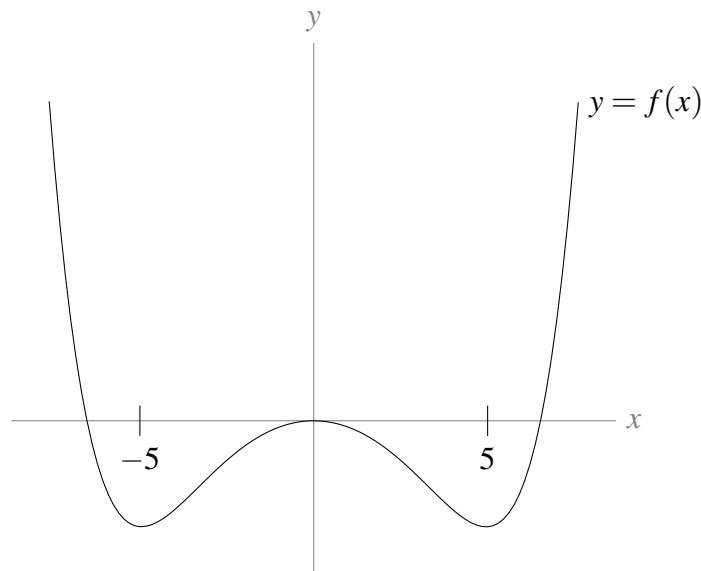

S-4: Global extrema will occur at critical or singular points in the interval $(-5, 5)$ or at the endpoints $x = 5, x = -5$.

$f'(x) = 2x + 6$. Since this is defined for all real numbers, there are no singular points. The only time $f'(x) = 0$ is when $x = -3$. This is inside the interval $[-5, 5]$. So, our points to check are $x = -3, x = -5$, and $x = 5$.

c	-3	-5	5
type	critical point	endpoint	endpoint
$f(c)$	-19	-15	45

The global maximum is 45 at $x = 5$ and the global minimum is -19 at $x = -3$.

S-5: Global extrema will occur at the endpoints of the interval, $x = -4$ and $x = 0$, or at singular or critical points inside the interval. Since $f(x)$ is a polynomial, it is differentiable everywhere, so there are no singular points. To find the critical points, we set the derivative equal to zero.

$$\begin{aligned}
 f'(x) &= 2x^2 - 4x - 30 \\
 0 &= 2x^2 - 4x - 30 &&= (2x - 10)(x + 3) \\
 x &= 5, -3
 \end{aligned}$$

The only critical point inside the interval is $x = -3$.

c	-3	-4	0
type	critical point	endpoint	endpoint
$f(c)$	61	$\frac{157}{3} = 52 + \frac{1}{3}$	7

The global maximum over the interval is 61 at $x = -3$, and the global minimum is 7 at $x = 0$.

Solutions to Exercises 8.3 — Jump to [TABLE OF CONTENTS](#)

S-1: We compute $f'(x) = 5x^4 - 5$, which means that $f(x)$ has no singular points (i.e., it is differentiable for all values of x), but it has two critical points:

$$\begin{aligned}0 &= 5x^4 - 5 \\0 &= x^4 - 1 = (x^2 + 1)(x^2 - 1) \\0 &= x^2 - 1 \\x &= \pm 1\end{aligned}$$

Note, however, that 1 is not in the interval $[-2, 0]$.

The global maximum and the global minimum for $f(x)$ on the interval $[-2, 0]$ will occur at $x = -2$, $x = 0$, or $x = -1$.

c	-2	0	-1
type	endpoint	endpoint	critical point
$f(c)$	-20	2	6

So, the global maximum is $f(-1) = 6$ while the global minimum is $f(-2) = -20$.

S-2: We compute $f'(x) = 5x^4 - 5$, which means that $f(x)$ has no singular points (i.e., it is differentiable for all values of x), but it has two critical points:

$$\begin{aligned}0 &= 5x^4 - 5 \\0 &= x^4 - 1 = (x^2 + 1)(x^2 - 1) \\0 &= x^2 - 1 \\x &= \pm 1\end{aligned}$$

Note, however, that -1 is not in the interval $[0, 2]$.

The global maximum and the global minimum for $f(x)$ on the interval $[0, 2]$ will occur at $x = 2$, $x = 0$, or $x = 1$.

c	2	0	1
type	endpoint	endpoint	critical point
$f(c)$	12	-10	-14

So, the global maximum is $f(2) = 12$ while the global minimum is $f(1) = -14$.

S-3: We compute $f'(x) = 6x^2 - 12x = 6x(x - 2)$, which means that $f(x)$ has no singular points (i.e., it is differentiable for all values of x), but it has the two critical points: $x = 0$ and $x = 2$. Note, however, 0 is not in the interval $[1, 4]$.

c	1	4	2
type	endpoint	endpoint	critical point
$f(c)$	-6	30	-10

So, the global maximum is $f(4) = 30$ while the global minimum is $f(2) = -10$.

S-4: Since $h(x)$ is a polynomial, it has no singular points. We compute its critical points:

$$\begin{aligned} h'(x) &= 3x^2 - 12 \\ 0 &= 3x^2 - 12 \\ x &= \pm 2 \end{aligned}$$

Notice as $x \rightarrow \infty$, $h(x) \rightarrow \infty$, and as $x \rightarrow -\infty$ $h(x) \rightarrow -\infty$. So Theorem 8.3.3 doesn't exactly apply. Instead, let's consider the signs of $h'(x)$.

x	$(-\infty, -2)$	$(-2, 2)$	$(2, \infty)$
$h'(x)$	> 0	< 0	> 0
$h(x)$	increasing	decreasing	increasing

So, $h(x)$ increases until $x = -2$, then decreases. That means $h(x)$ has a local maximum at $x = -2$. The function decreases from -2 until 2, after which it increases, so $h(x)$ has a local minimum at $x = 2$. We compute $f(-2) = 20$ and $f(2) = -12$.

S-5: Since $h(x)$ is a polynomial, it has no singular points. We compute its critical points:

$$\begin{aligned} h'(x) &= 6x^2 - 24 \\ 0 &= 6x^2 - 24 \\ x &= \pm 2 \end{aligned}$$

Notice as $x \rightarrow \infty$, $h(x) \rightarrow \infty$, and as $x \rightarrow -\infty$ $h(x) \rightarrow -\infty$. So Theorem 8.3.3 doesn't exactly apply. Instead, let's consider the signs of $h'(x)$.

x	$(-\infty, -2)$	$(-2, 2)$	$(2, \infty)$
$h'(x)$	> 0	< 0	> 0
$h(x)$	increasing	decreasing	increasing

So, $h(x)$ increases until $x = -2$, then decreases. That means $h(x)$ has a local maximum at $x = -2$. The function decreases from -2 until 2, after which it increases, so $h(x)$ has a local minimum at $x = 2$.

We compute $f(-2) = 33$ and $f(2) = -31$.

S-6: Suppose that Q is a distance of x from A . Then it is a distance of $18 - x$ from B .

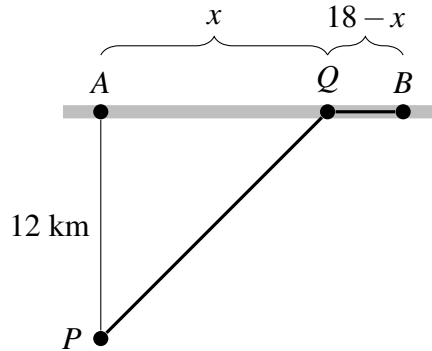

Using the Pythagorean Theorem, the distance from P to Q is $\sqrt{12^2 + x^2}$ kilometres, and the buggy travels 15 kph over this off-road stretch. The travel time from P to Q is $\frac{\sqrt{12^2 + x^2}}{15}$ hours.

The distance from Q to B is $18 - x$ kilometres, and the dune buggy travels 30 kph along this road. The travel time from Q to B is $\frac{18 - x}{30}$ hours. So, the total travel time is

$$f(x) = \frac{\sqrt{12^2 + x^2}}{15} + \frac{18 - x}{30}.$$

We wish to minimize this for $0 \leq x \leq 18$. We will test all singular points, critical points, and endpoints to find which yields the smallest value of $f(x)$. Since there are no singular points, we begin by locating the critical points.

$$\begin{aligned} 0 = f'(x) &= \frac{1}{15} \cdot \frac{1}{2} (144 + x^2)^{-1/2} (2x) - \frac{1}{30} \\ \frac{1}{15} \cdot \frac{x}{\sqrt{144 + x^2}} &= \frac{1}{30} \\ \frac{x}{\sqrt{144 + x^2}} &= \frac{1}{2} \\ \frac{x^2}{144 + x^2} &= \frac{1}{4} \\ 4x^2 &= 144 + x^2 \\ x &= \frac{12}{\sqrt{3}} = 4\sqrt{3} \end{aligned}$$

So the minimum travel times must be one of $f(0)$, $f(18)$, and $f(4\sqrt{3})$.

$$\begin{aligned} f(0) &= \frac{12}{15} + \frac{18}{30} = 1.4 \\ f(18) &= \frac{\sqrt{12^2 + 18^2}}{15} \approx 1.44 \\ f(4\sqrt{3}) &= \frac{\sqrt{144 + 144/3}}{15} + \frac{18 - 12/\sqrt{3}}{30} \approx 1.29 \end{aligned}$$

So Q should be $4\sqrt{3}$ km from A .

S-7: Let ℓ , w and h denote the length, width and height of the box respectively. We are told that $\ell wh = 4500$ and that $\ell = 3w$. Hence $h = \frac{4500}{\ell w} = \frac{4500}{3w^2} = \frac{1500}{w^2}$. The surface area of the box is

$$A = 2\ell w + 2\ell h + 2wh = 2\left(3w^2 + 3w\frac{1500}{w^2} + w\frac{1500}{w^2}\right) = 2\left(3w^2 + \frac{6000}{w}\right) = 6\left(w^2 + \frac{2000}{w}\right)$$

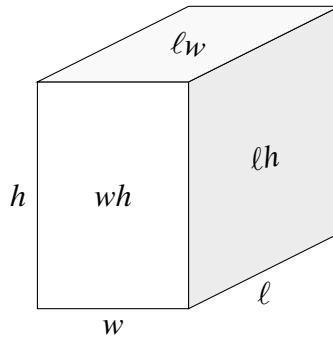

As w tends to zero or to infinity, the surface area approaches infinity. By Theorem 8.3.3 the minimum surface area must occur at a critical point of $w^2 + \frac{2000}{w}$.

$$\begin{aligned} 0 &= \frac{d}{dw} \left\{ w^2 + \frac{2000}{w} \right\} \\ &= 2w - \frac{2000}{w^2} \\ 2w &= \frac{2000}{w^2} \\ w^3 &= 1000 \\ w &= 10 \end{aligned}$$

Therefore,

$$\begin{aligned} \ell &= 3w = 30 \\ h &= \frac{1500}{w^2} = 15. \end{aligned}$$

The dimensions of the box with minimum surface area are $10 \times 30 \times 15$.

S-8: Let the length of the sides of the square base be b metres and let the height be h metres. The area of the base is b^2 , the area of the top is b^2 and the area of each of the remaining four sides is bh so the total cost is

$$\underbrace{5(b^2)}_{\text{cost of base}} + \underbrace{1(b^2 + 4bh)}_{\text{cost of 5 sides}} = 6b^2 + 4bh = 72$$

Solving for h ,

$$\begin{aligned}h &= \frac{72 - 6b^2}{4b} \\ &= \frac{6}{4} \left(\frac{12 - b^2}{b} \right) \\ &= \frac{3}{2} \left(\frac{12 - b^2}{b} \right)\end{aligned}$$

The volume is

$$\begin{aligned}V &= b^2 h = b^2 \cdot \frac{3}{2} \left(\frac{12 - b^2}{b} \right) \\ &= 18b - \frac{3}{2} b^3.\end{aligned}$$

This is the function we want to maximize. Since volume is never negative, the endpoints of the functions are the values of b that make the volume 0. So, the maximum volume will not occur at an endpoint, it will occur at a critical point. The only critical point is $b = 2$:

$$\begin{aligned}0 &= \frac{d}{db} \left\{ 18b - \frac{3}{2} b^3 \right\} \\ &= 18 - \frac{9}{2} b^2 \\ b^2 &= 4 \\ b &= 2, h = \frac{3}{2} \left(\frac{12 - 4}{2} \right) = 6\end{aligned}$$

The desired dimensions are $2 \times 2 \times 6$.

S-9: It suffices to consider X and Y such that the line XY is tangent to the circle. Otherwise we could reduce the area of the triangle by, for example, holding X fixed and reducing Y . So let X and Y be the x - and y -intercepts of the line tangent to the circle at $(\cos \theta, \sin \theta)$. Then $\frac{1}{X} = \cos \theta$ and $\frac{1}{Y} = \cos \left(\frac{\pi}{2} - \theta \right) = \sin \theta$. The area of the triangle is

$$\frac{1}{2} XY = \frac{1}{2 \cos \theta \sin \theta} = \frac{1}{\sin(2\theta)}$$

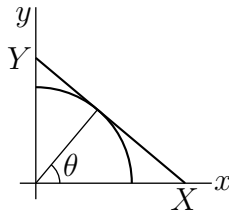

This is a minimum when $\sin(2\theta)$ is a maximum. That is when $2\theta = \frac{\pi}{2}$. Hence $X = \frac{1}{\cos(\pi/4)}$ and $Y = \frac{1}{\sin(\pi/4)}$. That is, $X = Y = \sqrt{2}$.

S-10: For ease of notation, we place the semicircle on a Cartesian plane with diameter along the x -axis and centre at the origin.

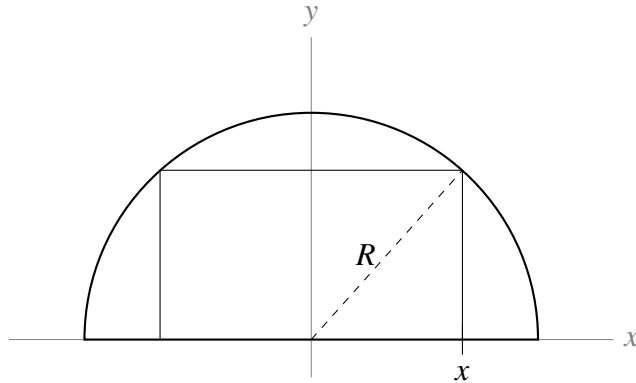

If x is the point where the rectangle touches the diameter to the right of the y -axis, then $2x$ is the width of the rectangle. The origin and the two right corners of the rectangle form a right triangle with hypotenuse R , so by the Pythagorean Theorem, the upper right hand corner of the rectangle is at $(x, \sqrt{R^2 - x^2})$. The perimeter of the rectangle is given by the function:

$$P(x) = 4x + 2\sqrt{R^2 - x^2}$$

So, this is what we optimize. The endpoints of the domain for this function are $x = 0$ and $x = R$. To find the critical points, we differentiate:

$$\begin{aligned} P'(x) &= 4 - \frac{2x}{\sqrt{R^2 - x^2}} \\ P'(x) = 0 &\iff 4 = \frac{2x}{\sqrt{R^2 - x^2}} \\ x &= 2\sqrt{R^2 - x^2} \\ x^2 &= 4(R^2 - x^2) \\ 5x^2 &= 4R^2 \\ x &= \frac{2}{\sqrt{5}}R \end{aligned}$$

Note that since our perimeter formula was defined to work only for x in $[0, R]$, we neglect the negative square root, $-\frac{2}{\sqrt{5}}R$.

Now, we find the size of the perimeter at the critical point and the endpoints:

c	0	R	$\frac{2}{\sqrt{5}}R$
type	endpoint	endpoint	critical point
$P(c)$	$2R$	$4R$	$2\sqrt{5}R$

So, the largest possible perimeter is $2\sqrt{5}R$ and the smallest possible perimeter is $2R$.

Remark: as a check on the correctness of our formula for $P(x)$, when $x = 0$ the rectangle degenerates to the line segment from $(0, 0)$ to $(0, R)$. The perimeter of this “width zero rectangle” is

$2R$, agreeing with $P(0)$. Similarly, when $x = R$ the rectangle degenerates to the line segment from $(R, 0)$ to $(-R, 0)$. The perimeter of this “width zero rectangle” is $4R$, agreeing with $P(R)$.

S-11: Let the cylinder have radius r and height h . If we imagine popping off the ends, they are two circular disks, each with surface area πr^2 . Then we imagine unrolling the remaining tube. It has height h , and its other dimension is given by the circumference of the disks, which is $2\pi r$. Then the area of the “unrolled tube” is $2\pi r h$.

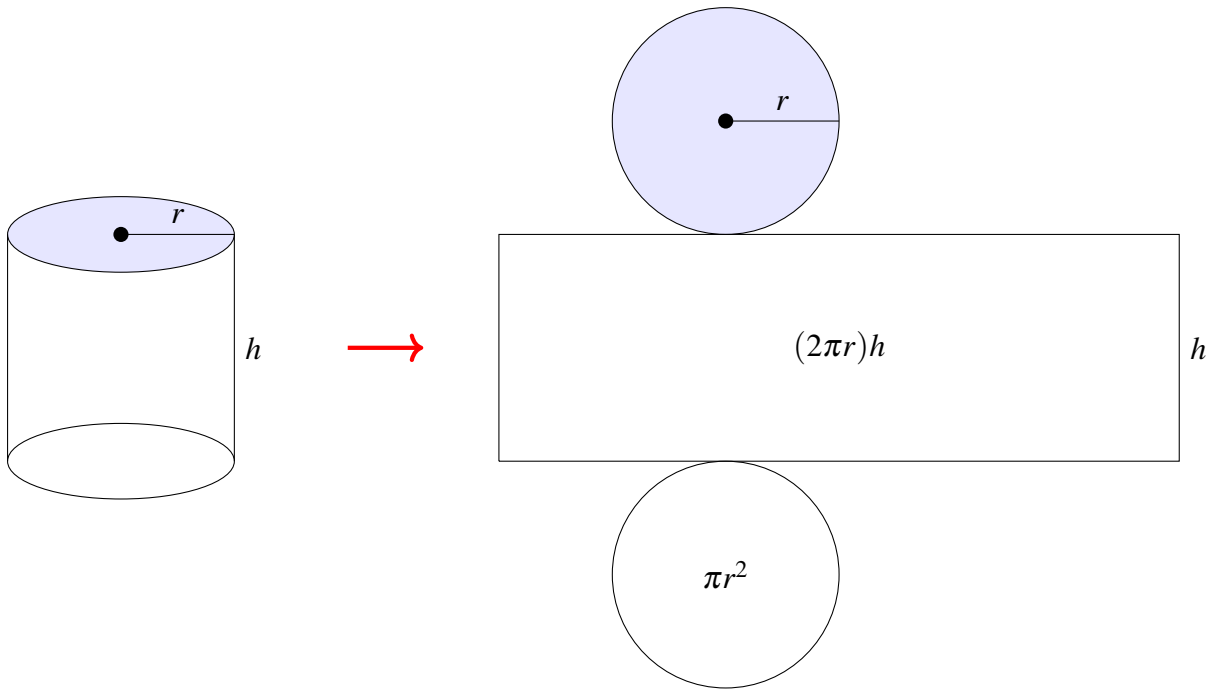

So, the surface area is $2\pi r^2 + 2\pi r h$. Since the area is given as A , we can solve for h :

$$\begin{aligned} A &= 2\pi r^2 + 2\pi r h \\ 2\pi r h &= A - 2\pi r^2 \\ h &= \frac{A - 2\pi r^2}{2\pi r}. \end{aligned}$$

Then we can write the volume as a function of the variable r and the constant A :

$$\begin{aligned} V(r) &= \pi r^2 h \\ &= \pi r^2 \left(\frac{A - 2\pi r^2}{2\pi r} \right) \\ &= \frac{1}{2} (Ar - 2\pi r^3) \end{aligned}$$

This is the function we want to maximize. Let's find its critical points.

$$\begin{aligned} V'(r) &= \frac{1}{2} (A - 6\pi r^2) \\ V'(r) = 0 &\iff A = 6\pi r^2 \iff r = \sqrt{\frac{A}{6\pi}} \end{aligned}$$

since negative values of r don't make sense. At this critical point,

$$\begin{aligned} V\left(\sqrt{\frac{A}{6\pi}}\right) &= \frac{1}{2} \left[A \left(\sqrt{\frac{A}{6\pi}}\right) - 2\pi \left(\sqrt{\frac{A}{6\pi}}\right)^3 \right] \\ &= \frac{1}{2} \left[\frac{A^{3/2}}{\sqrt{6\pi}} - \frac{2\pi A^{3/2}}{6\pi\sqrt{6\pi}} \right] \\ &= \frac{1}{2} \left[\frac{A^{3/2}}{\sqrt{6\pi}} - \frac{A^{3/2}}{3\sqrt{6\pi}} \right] \\ &= \frac{A^{3/2}}{3\sqrt{6\pi}}. \end{aligned}$$

We should also check the volume of the cylinder at the endpoints of the function. Since $r \geq 0$, one endpoint is $r = 0$. Since $h \geq 0$, and r grows as h shrinks, the other endpoint is whatever value of r causes h to be 0. We could find this value of r , but it's not strictly necessary: when $r = 0$, the volume of the cylinder is zero, and when $h = 0$, the volume of the cylinder is still zero. So, the maximum volume does not occur at the endpoints.

Therefore, the maximum volume is achieved at the critical point, where

$$V_{\max} = \frac{A^{3/2}}{3\sqrt{6\pi}}.$$

Remark: as a check, A has units m^2 and, because of the $A^{3/2}$, our answer has units m^3 , which are the correct units for a volume.

S-12: Denote by r the radius of the semicircle, and let h be the height of the rectangle.

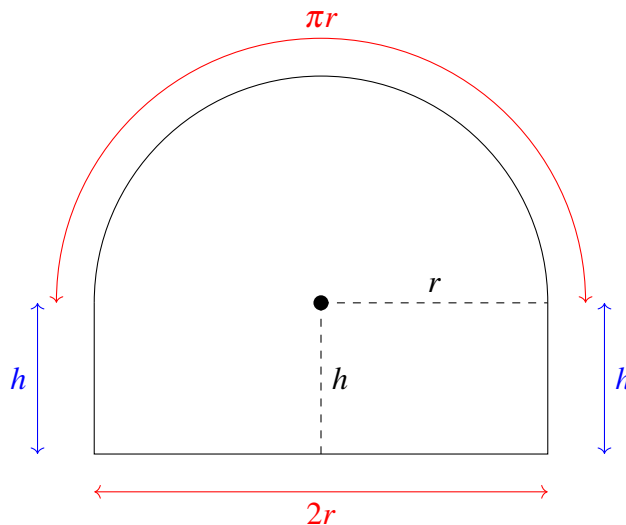

Since the perimeter is required to be P , the height, h , of the rectangle must obey

$$\begin{aligned} P &= \pi r + 2r + 2h \\ h &= \frac{1}{2}(P - \pi r - 2r) \end{aligned}$$

So the area is

$$\begin{aligned} A(r) &= \frac{1}{2}\pi r^2 + 2rh \\ &= \frac{1}{2}\pi r^2 + r(P - \pi r - 2r) \\ &= rP - \frac{1}{2}(\pi + 4)r^2 \end{aligned}$$

Finding all critical points:

$$\begin{aligned} 0 &= A'(r) = P - (\pi + 4)r \\ r &= \frac{P}{\pi + 4} \end{aligned}$$

Now we want to know what radius yields the maximum area. We notice that $A'(r) > 0$ for $r < \frac{P}{\pi + 4}$ and $A'(r) < 0$ for $r > \frac{P}{\pi + 4}$. So, $A(r)$ is increasing until the critical point, then decreasing after it. That means *the global maximum occurs at the critical point*, $r = \frac{P}{\pi + 4}$. The maximum area is

$$\begin{aligned} rP - \frac{1}{2}(\pi + 4)r^2 &= \frac{P^2}{\pi + 4} - \frac{1}{2}(\pi + 4)\frac{P^2}{(\pi + 4)^2} \\ &= \frac{P^2}{2(\pi + 4)} \end{aligned}$$

Remark: another way to see that the global maximum occurs at the critical point is to compare the area at the critical point to the areas at the endpoints of the function. The smallest value of r is 0, while the biggest is $\frac{P}{\pi + 2}$ (when the shape is simply a half-circle). Comparing $A(0)$, $A\left(\frac{P}{\pi + 2}\right)$, and $A\left(\frac{P}{\pi + 4}\right)$ is somewhat laborious, but certainly possible.

S-13:

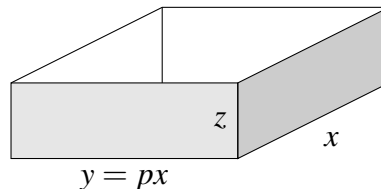

(a) The surface area of the pan is

$$\begin{aligned} xy + 2xz + 2yz &= px^2 + 2xz + 2pxz \\ &= px^2 + 2(1 + p)xz \end{aligned}$$

and the volume of the pan is $xyz = px^2z$. Assuming that all $A \text{ cm}^2$ is used, we have the constraint

$$px^2 + 2(1 + p)xz = A \quad \text{or} \quad z = \frac{A - px^2}{2(1 + p)x}$$

So

$$\begin{aligned}V(x) &= xyz = x(px) \left(\frac{A - px^2}{2(1+p)x} \right) \\ &= \frac{p}{2(1+p)} x(A - px^2)\end{aligned}$$

Using the product rule,

$$\begin{aligned}V'(x) &= \frac{p}{2(1+p)} [x(-2px) + (A - px^2)] \\ &= \frac{p}{2(1+p)} [A - 3px^2]\end{aligned}$$

The derivative $V'(x)$ is 0 when $x = \sqrt{\frac{A}{3p}}$. The derivative is positive (i.e. $V(x)$ is increasing) for $x < \sqrt{\frac{A}{3p}}$ and is negative (i.e. $V(x)$ is decreasing) for $x > \sqrt{\frac{A}{3p}}$. So the pan of maximum volume has dimensions $x = \sqrt{\frac{A}{3p}}$, $y = p\sqrt{\frac{A}{3p}} = \sqrt{\frac{Ap}{3}}$ and $z = \frac{2A/3}{2(1+p)\sqrt{A/(3p)}} = \frac{\sqrt{Ap}}{\sqrt{3}(1+p)}$.

(b) The volume of the pan from part (a) is

$$V(p) = \left(\sqrt{\frac{A}{3p}} \right) \left(p\sqrt{\frac{A}{3p}} \right) \frac{\sqrt{Ap}}{\sqrt{3}(1+p)} = \left(\frac{A}{3} \right)^{3/2} \frac{\sqrt{p}}{1+p}$$

Since

$$\frac{d}{dp} \left\{ \frac{\sqrt{p}}{1+p} \right\} = \frac{\frac{1}{2}(1+p)/\sqrt{p} - \sqrt{p}}{(1+p)^2} = \frac{\sqrt{p} \left(\frac{1}{p} - 1 \right)}{2(1+p)^2}$$

the volume is increasing with p for $p < 1$ and decreasing with p for $p > 1$. So the maximum volume is achieved for $p = 1$ (a square base).

S-14: (a) We use logarithmic differentiation.

$$\begin{aligned}f(x) &= x^x \\ \log f(x) &= \log(x^x) = x \log x \\ \frac{d}{dx} \{ \log f(x) \} &= \frac{d}{dx} \{ x \log x \} \\ \frac{f'(x)}{f(x)} &= x \left(\frac{1}{x} \right) + \log x = 1 + \log x \\ f'(x) &= f(x) (1 + \log x) = x^x (1 + \log x)\end{aligned}$$

(b) Since $x > 0$, $x^x > 0$. Therefore,

$$f'(x) = 0 \iff 1 + \log x = 0 \iff \log x = -1 \iff x = \frac{1}{e}$$

(c) Since $x > 0$, $x^x > 0$. So, the sign of $f'(x)$ is the same as the sign of $1 + \log x$.

For $x < \frac{1}{e}$, $\log x < -1$ and $f'(x) < 0$. That is, $f(x)$ decreases as x increases, when $x < \frac{1}{e}$. For $x > \frac{1}{e}$, $\log x > -1$ and $f'(x) > 0$. That is, $f(x)$ increases as x increases, when $x > \frac{1}{e}$. Hence $f(x)$ is a local minimum at $x = \frac{1}{e}$.

S-15: Call the length of the wire L units and suppose that it is cut ℓ units from one end. Make the square from the piece of length ℓ , and make the circle from the remaining piece of length $L - \ell$.

The square has perimeter ℓ , so its side length is $\ell/4$ and its area is $\left(\frac{\ell}{4}\right)^2$. The circle has circumference $L - \ell$, so its radius is $\frac{L - \ell}{2\pi}$ and its area is $\pi \left(\frac{L - \ell}{2\pi}\right)^2 = \frac{(L - \ell)^2}{4\pi}$.

The area enclosed by the shapes, when the square is made from a length of size ℓ , is

$$A(\ell) = \frac{\ell^2}{16} + \frac{(L - \ell)^2}{4\pi}$$

We want to find the global max and min for this function, given the constraint $0 \leq \ell \leq L$, so we find its derivative:

$$A'(\ell) = \frac{\ell}{8} - \frac{L - \ell}{2\pi} = \frac{\pi + 4}{8\pi}\ell - \frac{L}{2\pi}$$

Now, we find the critical point.

$$\begin{aligned} A'(\ell) &= 0 \\ \frac{\pi + 4}{8\pi}\ell &= \frac{L}{2\pi} \\ \ell &= \frac{4L}{\pi + 4} \end{aligned}$$

ℓ	0	L	$\frac{4L}{\pi + 4}$
type	endpoint	endpoint	critical point
$A(\ell)$	$\frac{L^2}{4\pi}$	$\frac{L^2}{16}$	$A\left(\frac{4L}{\pi + 4}\right)$

It seems obnoxious to evaluate $A\left(\frac{4L}{\pi + 4}\right)$, and the problem doesn't ask for it—but we still have to figure out whether it is a global max or min.

When $\ell < \frac{4L}{\pi + 4}$, $A'(\ell) < 0$, and when $\ell > \frac{4L}{\pi + 4}$, $A'(\ell) > 0$. So, $A(\ell)$ is decreasing until $\ell = \frac{4L}{\pi + 4}$, then increasing. That means our critical point $\ell = \frac{4L}{\pi + 4}$ is a local minimum.

So, the minimum occurs at the only critical point, which is $\ell = \left(\frac{4}{4 + \pi}\right)L$. This corresponds to $\frac{\ell}{L} = \frac{4}{4 + \pi}$: the proportion of the wire that is cut is $\frac{4}{4 + \pi}$.

The maximum has to be either at $\ell = 0$ or at $\ell = L$. As $A(0) = \frac{L^2}{4\pi} > A(L) = \frac{L^2}{16}$, the maximum has $\ell = 0$ (that is, no square).

Solutions to Exercises 8.4 — Jump to [TABLE OF CONTENTS](#)

Solutions to Exercises 9.1 — Jump to [TABLE OF CONTENTS](#)

S-1: Since $f(0)$ is closer to $g(0)$ than it is to $h(0)$, you would probably want to estimate $f(0) \approx g(0) = 1 + 2\sin(1)$ if you had the means to efficiently figure out what $\sin(1)$ is, and if you were concerned with accuracy. If you had a calculator, you could use this estimation. Also, later in this chapter we will learn methods of approximating $\sin(1)$ that do not require a calculator, but they do require time.

Without a calculator, or without a lot of time, using $f(0) \approx h(0) = 0.7$ probably makes the most sense. It isn't as accurate as $f(0) \approx g(0)$, but you get an estimate very quickly, without worrying about figuring out what $\sin(1)$ is.

Remark: when you're approximating something in real life, there probably won't be an obvious "correct" way to do it. There's usually a trade-off between accuracy and ease.

S-2: 0.93 is pretty close to 1, and we know $\log(1) = 0$, so we estimate $\log(0.93) \approx \log(1) = 0$.

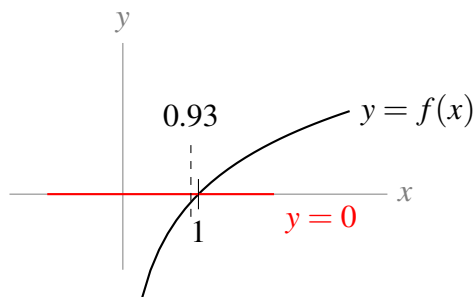

S-3: We don't know $\arcsin(0.1)$, but 0.1 is reasonably close to 0, and $\arcsin(0) = 0$. So, we estimate $\arcsin(0.1) \approx 0$.

S-4: We don't know $\tan(1)$, but we do know $\tan\left(\frac{\pi}{3}\right) = \sqrt{3}$. Since $\frac{\pi}{3} \approx 1.047$ is pretty close to 1, we estimate $\sqrt{3}\tan(1) \approx \sqrt{3}\tan\left(\frac{\pi}{3}\right) = (\sqrt{3})^2 = 3$.

S-5: Since 10.1 is pretty close to 10, we estimate $10.1^3 \approx 10^3 = 1000$.

Remark: these kinds of approximations are very useful when you are doing computations. It's easy to make a mistake in your work, and having in mind that 10.1^3 should be *about* a thousand is a good way to check that whatever answer you have makes sense.

Solutions to Exercises 9.2 — Jump to [TABLE OF CONTENTS](#)

S-1: The linear approximation is $L(x) = 3x - 9$. Since we're approximating at $x = 5$, $f(5) = L(5)$, and $f'(5) = L'(5)$. However, there is no guarantee that $f(x)$ and $L(x)$ have the same value when $x \neq 5$. So:

(a) $f(5) = L(5) = 6$

(b) $f'(5) = L'(5) = 3$

(c) there is not enough information to find $f(0)$.

S-2: The linear approximation is a line, passing through $(2, f(2))$, with slope $f'(2)$. That is, the linear approximation to $f(x)$ about $x = 2$ is the tangent line to $f(x)$ at $x = 2$. It is shown below in red.

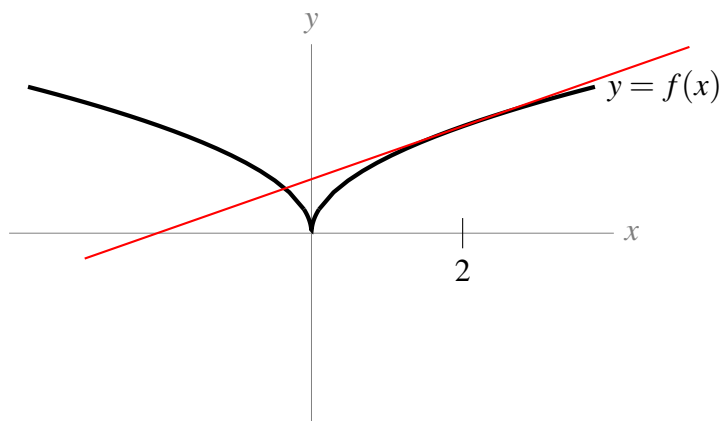

S-3: For any constant a , $f(a) = (2a + 5)$, and $f'(a) = 2$, so our approximation gives us

$$f(x) \approx (2a + 5) + 2(x - a) = 2x + 5$$

Since $f(x)$ itself is a linear function, the linear approximation is actually just $f(x)$ itself. As a consequence, the linear approximation is perfectly accurate for all values of x .

S-4: We have no idea what $f(0.93)$ is, but 0.93 is pretty close to 1, and we definitely know $f(1)$. The linear approximation of $f(x)$ about $x = 1$ is given by

$$f(x) \approx f(1) + f'(1)(x - 1)$$

So, we calculate:

$$f(1) = \log(1) = 0$$

$$f'(x) = \frac{1}{x}$$

$$f'(1) = \frac{1}{1} = 1$$

Therefore,

$$f(x) \approx 0 + 1(x - 1) = x - 1$$

When $x = 0.93$:

$$f(0.93) \approx 0.93 - 1 = -0.07$$

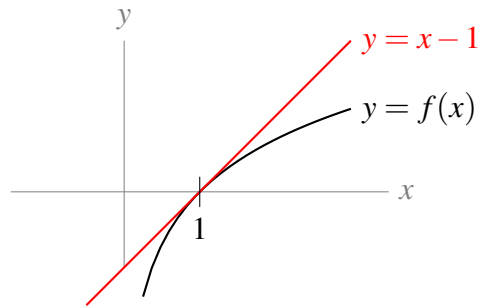

S-5: We approximate the function $f(x) = \sqrt{x}$ about $x = 4$, since 4 is a perfect square and it is close to 5.

$$\begin{aligned} f(4) &= \sqrt{4} = 2 \\ f'(x) &= \frac{1}{2\sqrt{x}} \quad \Rightarrow \quad f'(4) = \frac{1}{2\sqrt{4}} = \frac{1}{4} \\ f(x) &\approx f(4) + f'(4)(x - 4) = 2 + \frac{1}{4}(x - 4) \\ f(5) &\approx 2 + \frac{1}{4}(5 - 4) = \frac{9}{4} \end{aligned}$$

We estimate $\sqrt{5} \approx \frac{9}{4}$.

Remark: $\left(\frac{9}{4}\right)^2 = \frac{81}{16}$, which is pretty close to $\frac{80}{16} = 5$. Our approximation seems pretty good.

S-6: We approximate the function $f(x) = \sqrt[5]{x}$. We need to centre the approximation about some value $x = a$ such that we know $f(a)$ and $f'(a)$, and a is not too far from 30.

$$\begin{aligned} f(x) &= \sqrt[5]{x} = x^{\frac{1}{5}} \\ f'(x) &= \frac{1}{5}x^{-\frac{4}{5}} = \frac{1}{5\sqrt[5]{x^4}} \end{aligned}$$

a needs to be a number whose fifth root we know. Since $\sqrt[5]{32} = 2$, and 32 is reasonably close to 30, $a = 32$ is a great choice.

$$\begin{aligned} f(32) &= \sqrt[5]{32} = 2 \\ f'(32) &= \frac{1}{5 \cdot 2^4} = \frac{1}{80} \end{aligned}$$

The linear approximation of $f(x)$ about $x = 32$ is

$$f(x) \approx 2 + \frac{1}{80}(x - 32)$$

When $x = 30$:

$$f(30) \approx 2 + \frac{1}{80}(30 - 32) = 2 - \frac{1}{40} = \frac{79}{40}$$

We estimate $\sqrt[5]{30} \approx \frac{79}{40}$.

Remark: $\frac{79}{40} = 1.975$, while $\sqrt[5]{30} \approx 1.97435$. This is a decent estimation.

S-7: If $f(x) = x^3$, then $f(10.1) = 10.1^3$, which is the value we want to estimate. Let's take the linear approximation of $f(x)$ about $x = 10$:

$$\begin{aligned} f(10) &= 10^3 = 1000 \\ f'(x) &= 3x^2 \\ f'(10) &= 3(10^2) = 300 \\ f(a) &\approx f(10) + f'(10)(x - 10) \\ &= 1000 + 300(x - 10) \\ f(10.1) &\approx 1000 + 300(10.1 - 10) = 1030 \end{aligned}$$

We estimate $10.1^3 \approx 1030$. If we calculate 10.1^3 exactly (which is certainly possible to do by hand), we get 1030.301.

Remark: in the previous subsection, we used a constant approximation to estimate $10.1^3 \approx 1000$. That approximation was easy to do in your head, in a matter of seconds. The linear approximation is more accurate, but not much faster than simply calculating 10.1^3 .

S-8: There are many possible answers. One is:

$$f(x) = \sin x \quad a = 0 \quad b = \pi$$

We know that $f(\pi) = 0$ and $f(0) = 0$. Using a constant approximation of $f(x)$ about $x = 0$, our estimation is $f(\pi) \approx f(0) = 0$, which is exactly the correct value. However, if we make a linear approximation of $f(x)$ about $x = 0$, we get

$$f(\pi) \approx f(0) + f'(0)(\pi - 0) = \sin(0) + \cos(0)\pi = \pi$$

which is not exactly the correct value.

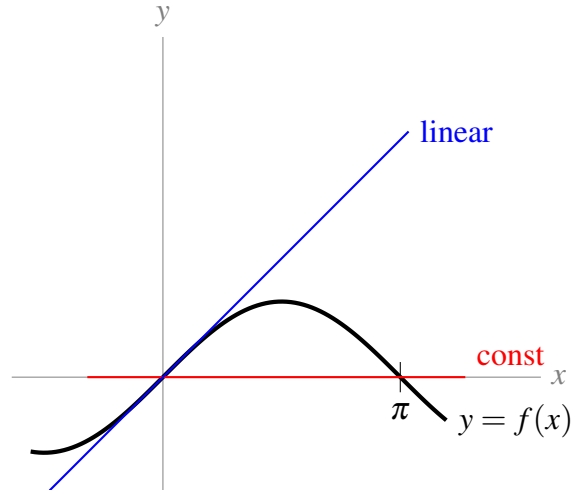

Remark: in reality, we wouldn't estimate $\sin(\pi)$, because we know its value exactly. The purpose of this problem is to demonstrate that fancier approximations are not *always* more accurate. At the of this section, we'll talk about how to bound the error of your estimations, to make sure that you are finding something sufficiently accurate.

S-9: The linear approximation $L(x)$ of $f(x)$ about $x = a$ is chosen so that $L(a) = f(a)$ and $L'(a) = f'(a)$. So,

$$L'(a) = f'(a) = \frac{1}{1+a^2}$$

$$\frac{1}{4} = \frac{1}{1+a^2}$$

$$a = \pm\sqrt{3}$$

We've narrowed down a to $\sqrt{3}$ or $-\sqrt{3}$. Recall the linear approximation of $f(x)$ about $x = a$ is $f(a) + f'(a)(x-a)$, so its constant term is $f(a) - af'(a) = \arctan(a) - \frac{a}{1+a^2}$. We compute this for $a = \sqrt{3}$ and $a = -\sqrt{3}$.

$$a = \sqrt{3}: \arctan(a) - \frac{a}{1+a^2} = \arctan(\sqrt{3}) - \frac{\sqrt{3}}{1+(\sqrt{3})^2} = \frac{\pi}{3} - \frac{\sqrt{3}}{4} = \frac{4\pi - \sqrt{27}}{12}$$

$$a = -\sqrt{3}: \arctan(a) - \frac{a}{1+a^2} = \arctan(-\sqrt{3}) - \frac{-\sqrt{3}}{1+(-\sqrt{3})^2} = -\frac{\pi}{3} + \frac{\sqrt{3}}{4} = \frac{-4\pi + \sqrt{27}}{12}$$

So, when $a = \sqrt{3}$,

$$L(x) = \frac{1}{4}x + \frac{4\pi - \sqrt{27}}{12}$$

and this does not hold when $a = -\sqrt{3}$. We conclude $a = \sqrt{3}$.

◆◆◆
Solutions to Exercises 9.3 — Jump to [TABLE OF CONTENTS](#)

S-1: If $Q(x)$ is the quadratic approximation of f about 3, then $Q(3) = f(3)$, $Q'(3) = f'(3)$, and $Q''(3) = f''(3)$. There is no guarantee that $f(x)$ and $Q(x)$ share the same third derivative, though, so we do not have enough information to know $f'''(3)$.

$$\begin{aligned}f(3) &= -3^2 + 6(3) = 9 \\f'(3) &= \left. \frac{d}{dx} \{-x^2 + 6x\} \right|_{x=3} = -2x + 6 \Big|_{x=3} = 0 \\f''(3) &= \left. \frac{d^2}{dx^2} \{-x^2 + 6x\} \right|_{x=3} = \left. \frac{d}{dx} \{-2x + 6\} \right|_{x=3} = -2\end{aligned}$$

S-2: The quadratic approximation of $f(x)$ about $x = a$ is

$$f(x) \approx f(a) + f'(a)(x-a) + \frac{1}{2}f''(a)(x-a)^2$$

We substitute $f(a) = 2a + 5$, $f'(a) = 2$, and $f''(a) = 0$:

$$f(x) \approx (2a + 5) + 2(x - a) = 2x + 5$$

So, our approximation is $f(x) \approx 2x + 5$.

Remark: Our approximation is exact for every value of x . This will always happen with a quadratic approximation of a function that is quadratic, linear, or constant.

S-3: We approximate the function $f(x) = \log x$ about the point $x = 1$. We choose 1 because it is close to 0.93, and we can evaluate $f(x)$ and its first two derivatives at $x = 1$.

$$\begin{aligned}f(1) &= 0 \\f'(x) &= \frac{1}{x} \quad \Rightarrow \quad f'(1) = 1 \\f''(x) &= \frac{-1}{x^2} \quad \Rightarrow \quad f''(1) = -1\end{aligned}$$

So,

$$\begin{aligned}f(x) &\approx f(1) + f'(1)(x-1) + \frac{1}{2}f''(1)(x-1)^2 \\&= 0 + (x-1) - \frac{1}{2}(x-1)^2\end{aligned}$$

When $x = 0.93$:

$$f(0.93) \approx (0.93 - 1) - \frac{1}{2}(0.93 - 1)^2 = -0.07 - \frac{1}{2}(0.0049) = -0.07245$$

We estimate $\log(0.93) \approx -0.07245$.

Remark: a calculator approximates $\log(0.93) \approx -0.07257$. We're pretty close.

S-4: We approximate the function $f(x) = \cos x$. We can easily evaluate $\cos x$ and $\sin x$ ($\sin x$ will appear in the first derivative) at $x = 0$, and 0 is quite close to $\frac{1}{15}$, so we centre our approximation about $x = 0$.

$$\begin{aligned}f(0) &= 1 \\f'(x) &= -\sin x \\f'(0) &= -\sin(0) = 0 \\f''(x) &= -\cos x \\f''(0) &= -\cos(0) = -1\end{aligned}$$

Using the quadratic approximation $f(x) \approx f(0) + f'(0)(x-0) + \frac{1}{2}f''(0)(x-0)^2$:

$$\begin{aligned}f(x) &\approx 1 - \frac{1}{2}x^2 \\f\left(\frac{1}{15}\right) &\approx 1 - \frac{1}{2 \cdot 15^2} = \frac{449}{450}\end{aligned}$$

We approximate $\cos\left(\frac{1}{15}\right) \approx \frac{449}{450}$.

Remark: $\frac{449}{450} = 0.9977\bar{7}$, while a calculator gives $\cos\left(\frac{1}{15}\right) \approx 0.9977786$. Our approximation has an error of about 0.000001.

S-5: The quadratic approximation of a function $f(x)$ about $x = a$ is

$$f(x) \approx f(a) + f'(a)(x-a) + \frac{1}{2}f''(a)(x-a)^2$$

We compute derivatives.

$$\begin{aligned}f(0) &= e^0 = 1 \\f'(x) &= 2e^{2x} \\f'(0) &= 2e^0 = 2 \\f''(x) &= 4e^{2x} \\f''(0) &= 4e^0 = 4\end{aligned}$$

Substituting:

$$\begin{aligned}f(x) &\approx 1 + 2(x-0) + \frac{4}{2}(x-0)^2 \\f(x) &\approx 1 + 2x + 2x^2\end{aligned}$$

S-6: There are a few functions we could choose to approximate. For example:

- $f(x) = x^{4/3}$. In this case, we would probably choose to approximate $f(x)$ about $x = 8$ (since 8 is a cube, $8^{4/3} = 2^4 = 16$ is something we can evaluate) or $x = 1$.
- $f(x) = 5^x$. We can easily figure out $f(x)$ when x is a whole number, so we would want to centre our approximation around some whole number $x = a$, but then $f'(a) = 5^a \log(5)$ gives us a problem: without a calculator, it's hard to know what $\log(5)$ is.
- Since $5^{4/3} = 5\sqrt[3]{5}$, we can use $f(x) = 5\sqrt[3]{x}$. As in the first bullet, we would centre about $x = 8$, or $x = 1$.

There isn't much difference between the first and third bullets. We'll go with $f(x) = 5\sqrt[3]{x}$, centred about $x = 8$.

$$\begin{aligned} f(x) &= 5x^{\frac{1}{3}} & \Rightarrow & f(8) = 5 \cdot 2 = 10 \\ f'(x) &= \frac{5}{3}x^{-\frac{2}{3}} & \Rightarrow & f'(8) = \frac{5}{3}(2^{-2}) = \frac{5}{12} \\ f''(x) &= \frac{5}{3}\left(-\frac{2}{3}\right)x^{-\frac{5}{3}} = -\frac{10}{9}x^{-\frac{5}{3}} & \Rightarrow & f''(8) = -\frac{10}{9}(2^{-5}) = -\frac{5}{144} \end{aligned}$$

Using the quadratic approximation $f(x) \approx f(a) + f'(a)(x-a) + \frac{1}{2}f''(a)(x-a)^2$:

$$\begin{aligned} f(x) &\approx 10 + \frac{5}{12}(x-8) - \frac{5}{288}(x-8)^2 \\ f(5) &\approx 10 + \frac{5}{12}(-3) - \frac{5}{288}(9) = \frac{275}{32} \end{aligned}$$

We estimate $5^{4/3} \approx \frac{275}{32}$

Remark: $\frac{275}{32} = 8.59375$, and a calculator gives $5^{4/3} \approx 8.5499$. Although 5 and 8 are somewhat far apart, our estimate is only off by about 0.04.

S-7:

- (a) For every value of n , the term being added is simply the constant 1. So,

$$\sum_{n=5}^{30} 1 = 1 + 1 + \cdots + 1. \text{ The trick is figuring out how many 1s are added. Our index } n \text{ takes}$$

on all integers from 5 to 30, *including* 5 and 30, which is 26 numbers. So, $\sum_{n=5}^{30} = 26$.

If you're having a hard time seeing why the sum is 26, instead of 25, think of it this way: there are thirty numbers in the collection $\{1, 2, 3, 4, 5, 6, \dots, 29, 30\}$. If we remove the first four, we get $30 - 4 = 26$ numbers in the collection $\{5, 6, \dots, 30\}$.

- (b)

$$\begin{aligned} \sum_{n=1}^3 [2(n+3) - n^2] &= \underbrace{2(1+3) - 1^2}_{n=1} + \underbrace{2(2+3) - 2^2}_{n=2} + \underbrace{2(3+3) - 3^2}_{n=3} \\ &= 8 - 1 + 10 - 4 + 12 - 9 = 16 \end{aligned}$$

(c)

$$\begin{aligned} \sum_{n=1}^{10} \left[\frac{1}{n} - \frac{1}{n+1} \right] &= \underbrace{\frac{1}{1} - \frac{1}{1+1}}_{n=1} + \underbrace{\frac{1}{2} - \frac{1}{2+1}}_{n=2} + \underbrace{\frac{1}{3} - \frac{1}{3+1}}_{n=3} + \underbrace{\frac{1}{4} - \frac{1}{4+1}}_{n=4} + \underbrace{\frac{1}{5} - \frac{1}{5+1}}_{n=5} \\ &+ \underbrace{\frac{1}{6} - \frac{1}{6+1}}_{n=6} + \underbrace{\frac{1}{7} - \frac{1}{7+1}}_{n=7} + \underbrace{\frac{1}{8} - \frac{1}{8+1}}_{n=8} + \underbrace{\frac{1}{9} - \frac{1}{9+1}}_{n=9} + \underbrace{\frac{1}{10} - \frac{1}{10+1}}_{n=10} \end{aligned}$$

Most of these cancel!

$$\begin{aligned} &= \frac{1}{1} - \underbrace{\frac{1}{2} + \frac{1}{2}}_0 + \underbrace{\frac{1}{3} - \frac{1}{3}}_0 + \underbrace{\frac{1}{4} - \frac{1}{4}}_0 + \underbrace{\frac{1}{5} - \frac{1}{5}}_0 + \underbrace{\frac{1}{6} - \frac{1}{6}}_0 \\ &\quad - \underbrace{\frac{1}{7} + \frac{1}{7}}_0 + \underbrace{\frac{1}{8} - \frac{1}{8}}_0 + \underbrace{\frac{1}{9} - \frac{1}{9}}_0 + \underbrace{\frac{1}{10} - \frac{1}{10}}_0 - \frac{1}{11} \\ &= 1 - \frac{1}{11} = \frac{10}{11} \end{aligned}$$

(d)

$$\begin{aligned} \sum_{n=1}^4 \frac{5 \cdot 2^n}{4^{n+1}} &= 5 \sum_{n=1}^4 \frac{2^n}{4 \cdot 4^n} = \frac{5}{4} \sum_{n=1}^4 \frac{2^n}{4^n} = \frac{5}{4} \sum_{n=1}^4 \frac{1}{2^n} \\ &= \frac{5}{4} \left(\underbrace{\frac{1}{2}}_{n=1} + \underbrace{\frac{1}{4}}_{n=2} + \underbrace{\frac{1}{8}}_{n=3} + \underbrace{\frac{1}{16}}_{n=4} \right) = \frac{75}{64} \end{aligned}$$

S-8: For each of these, there are many solutions. We provide some below.

(a) $1 + 2 + 3 + 4 + 5 = \sum_{n=1}^5 n$

(b) $2 + 4 + 6 + 8 = \sum_{n=1}^4 2n$

(c) $3 + 5 + 7 + 9 + 11 = \sum_{n=1}^5 (2n + 1)$

(d) $9 + 16 + 25 + 36 + 49 = \sum_{n=3}^7 n^2$

(e) $9 + 4 + 16 + 5 + 25 + 6 + 36 + 7 + 49 + 8 = \sum_{n=3}^7 (n^2 + n + 1)$

$$(f) \quad 8 + 15 + 24 + 35 + 48 = \sum_{n=3}^7 (n^2 - 1)$$

$$(g) \quad 3 - 6 + 9 - 12 + 15 - 18 = \sum_{n=1}^6 (-1)^{n+1} 3n$$

Remark: if we had written $(-1)^n$ instead of $(-1)^{n+1}$, with everything else the same, the signs would have been reversed.

S-9: Let's start by taking the first two derivative of $f(x)$.

$$\begin{aligned} f(x) &= 2 \arcsin x && \Rightarrow && f(0) = 2(0) = 0 \\ f'(x) &= \frac{2}{\sqrt{1-x^2}} && \Rightarrow && f'(0) = \frac{2}{1} = 2 \\ f''(x) &= \frac{d}{dx} \left\{ 2(1-x^2)^{-\frac{1}{2}} \right\} \\ &= 2 \left(-\frac{1}{2} \right) (1-x^2)^{-\frac{3}{2}} (-2x) && \text{(chain rule)} \\ &= \frac{2x}{\left(\sqrt{1-x^2} \right)^3} && \Rightarrow && f''(0) = 0 \end{aligned}$$

Now, we can find the quadratic approximation about $x = 0$.

$$\begin{aligned} f(x) &\approx f(0) + f'(0)x + \frac{1}{2}f''(0)x^2 \\ &= 2x \\ f(1) &\approx 2 \end{aligned}$$

Our quadratic approximation gives $2 \arcsin(1) \approx 2$. However, $2 \arcsin(1)$ is exactly equal to $2 \left(\frac{\pi}{2} \right) = \pi$. We've just made the rather unfortunate approximation $\pi \approx 2$.

S-10: From the text, the quadratic approximation of e^x about $x = 0$ is

$$e^x \approx 1 + x + \frac{1}{2}x^2$$

So,

$$e = e^1 \approx 1 + 1 + \frac{1}{2} = 2.5$$

We estimate $e \approx 2.5$.

Remark: actually, $e \approx 2.718$.

S-11:

- First, we'll show that

(a), (d), (e)

are equivalent:

$$(d) = 2 \sum_{n=1}^{10} n = 2(1 + 2 + \cdots + 10) = 2(1) + 2(2) + \cdots + 2(10) = \sum_{n=1}^{10} 2n = (a)$$

So (a) and (d) are equivalent.

$$(e) = 2 \sum_{n=2}^{11} (n-1) = 2(1 + 2 + \cdots + 10) = (d)$$

So (e) and (d) are equivalent.

- Second, we'll show that

(b), (g)

are equivalent.

$$(g) = \frac{1}{4} \sum_{n=1}^{10} \left(\frac{4^{n+1}}{2^n} \right) = \frac{1}{4} \sum_{n=1}^{10} \left(\frac{4 \cdot 4^n}{2^n} \right) = \frac{4}{4} \sum_{n=1}^{10} \left(\frac{4^n}{2^n} \right) = \sum_{n=1}^{10} \left(\frac{4}{2} \right)^n = \sum_{n=1}^{10} 2^n = (b)$$

- Third, we'll show that

(c), (f)

are equivalent.

$$(f) = \sum_{n=5}^{14} (n-4)^2 = 1^2 + 2^2 + \cdots + 10^2 = \sum_{n=1}^{10} n^2 = (c)$$

- Now, we have three groups, where each group consists of equivalent expressions. To be quite thorough, we should show that no two of these groups contain expressions that are secretly equivalent. They would be hard to evaluate, but we can bound them and show that no two expressions in two separate groups could possibly be equivalent. Notice that

$$\sum_{n=1}^{10} 2^n = 2^1 + 2^2 + \cdots + 2^{10} > 2^{10} = 1024$$

$$\sum_{n=1}^{10} n^2 < \sum_{n=1}^{10} 10^2 = 10(100) = 1000$$

$$\sum_{n=1}^{10} n^2 = 1^2 + 2^2 + \cdots + 8^2 + 9^2 + 10^2 > 8^2 + 9^2 + 10^2 = 245$$

$$\sum_{n=1}^{10} 2n < \sum_{n=1}^{10} 20 = 200$$

The expressions in the blue group add to less than 200, but the expressions in the green group add to more than 245, and the expressions in the red group add to more than 1024, so the blue groups expressions can't possibly simplify to the same number as the red and green group expressions.

The expressions in the green group add to less than 1000. Since the expressions in the red group add to more than 1024, the expressions in the green and red groups can't possibly simplify to the same numbers.

We group our expressions in to collections of equivalent expressions as follows:

$\{(a), (d), (e)\}$, $\{(b), (g)\}$, $\{(c), (f)\}$

Solutions to Exercises 9.4 — Jump to [TABLE OF CONTENTS](#)

S-1: Since $T_3(x)$ is the third-degree Taylor polynomial for $f(x)$ about $x = 1$:

- $T_3(1) = f(1)$
- $T_3'(1) = f'(1)$
- $T_3''(1) = f''(1)$
- $T_3'''(1) = f'''(1)$

In particular, $f''(1) = T_3''(1)$.

$$T_3'(x) = 3x^2 - 10x + 9$$

$$T_3''(x) = 6x - 10$$

$$T_3''(1) = 6 - 10 = -4$$

So, $f''(1) = -4$.

S-2: In Question 1, we differentiated the Taylor polynomial to find its derivative. We don't really want to differentiate this ten times, though, so let's look for another way. Unlike Question 1, our Taylor polynomial is given to us in a form very similar to its definition. The n th degree Taylor polynomial for $f(x)$ about $x = 5$ is

$$T_n(x) = \sum_{k=0}^n \frac{f^{(k)}(5)}{k!} (x-5)^k$$

So,

$$\sum_{k=0}^n \frac{f^{(k)}(5)}{k!} (x-5)^k = \sum_{k=0}^n \frac{2k+1}{3k-9} (x-5)^k$$

For any k from 0 to n ,

$$\frac{f^{(k)}(5)}{k!} = \frac{2k+1}{3k-9}$$

In particular, when $k = 10$,

$$\frac{f^{(10)}(5)}{10!} = \frac{20+1}{30-9} = 1$$
$$f^{(10)}(5) = 10!$$

S-3: The fourth-degree Maclaurin polynomial for $f(x)$ is

$$T_4(x) = f(0) + f'(0)x + \frac{1}{2}f''(0)x^2 + \frac{1}{3!}f'''(0)x^3 + \frac{1}{4!}f^{(4)}(0)x^4$$

while the third-degree Maclaurin polynomial for $f(x)$ is

$$T_3(x) = f(0) + f'(0)x + \frac{1}{2}f''(0)x^2 + \frac{1}{3!}f'''(0)x^3$$

So, we simply “chop off” the part of $T_4(x)$ that includes x^4 :

$$T_3(x) = -x^3 + x^2 - x + 1$$

S-4: We saw this kind of problem in Question 3. The fourth-degree Taylor polynomial for $f(x)$ about $x = 1$ is

$$T_4(x) = f(1) + f'(1)(x-1) + \frac{1}{2}f''(1)(x-1)^2 + \frac{1}{3!}f'''(1)(x-1)^3 + \frac{1}{4!}f^{(4)}(1)(x-1)^4$$

while the third-degree Taylor polynomial for $f(x)$ about $x = 1$ is

$$T_3(x) = f(1) + f'(1)(x-1) + \frac{1}{2}f''(1)(x-1)^2 + \frac{1}{3!}f'''(1)(x-1)^3$$

In Question 3 we “chopped off” the term of degree 4 to get $T_3(x)$. However, *our polynomial is not in this form*. It’s not clear, right away, what the term $f^{(4)}(x-1)^4$ is in our given $T_4(x)$. So, we will use a different method from Question 3.

One option is to do some fancy algebra to get $T_4(x)$ into the standard form of a Taylor polynomial. Another option (which we will use) is to recover $f(1)$, $f'(1)$, $f''(1)$, and $f'''(1)$ from $T_4(x)$.

Recall that $T_4(x)$ and $f(x)$ have the same values at $x = 1$ (although maybe not anywhere else!), and they also have the same first, second, third, and fourth derivatives at $x = 1$ (but again, maybe not anywhere else, and maybe their fifth derivatives don’t agree). This tells us the following:

$$\begin{array}{lll} T_4(x) = x^4 + x^3 - 9 & \Rightarrow & f(1) = T_4(1) = -7 \\ T_4'(x) = 4x^3 + 3x^2 & \Rightarrow & f'(1) = T_4'(1) = 7 \\ T_4''(x) = 12x^2 + 6x & \Rightarrow & f''(1) = T_4''(1) = 18 \\ T_4'''(x) = 24x + 6 & \Rightarrow & f'''(1) = T_4'''(1) = 30 \end{array}$$

Now, we can write the third-degree Taylor polynomial for $f(x)$ about $x = 1$:

$$\begin{aligned} T_3(x) &= -7 + 7(x-1) + \frac{1}{2}(18)(x-1)^2 + \frac{1}{3!}(30)(x-1)^3 \\ &= -7 + 7(x-1) + 9(x-1)^2 + 5(x-1)^3 \end{aligned}$$

Remark: expanding the expression above, we get the equivalent polynomial

$T_3(x) = 5x^3 - 6x^2 + 4x - 10$. From this, it is clear that we can't just "chop off" the term with x^4 to change $T_4(x)$ into $T_3(x)$ when the Taylor polynomial is not centred about $x = 0$.

S-5: The n th degree Taylor polynomial for $f(x)$ about $x = 5$ is

$$T_n(x) = \sum_{k=0}^n \frac{1}{k!} f^{(k)}(5)(x-5)^k$$

We expand this somewhat:

$$T_n(x) = f(5) + f'(x-5) + \cdots + \boxed{\frac{1}{10!} f^{(10)}(5)(x-5)^{10}} + \cdots + \frac{1}{n!} f^{(n)}(5)(x-1)^n$$

So, the coefficient of $(x-5)^{10}$ is $\frac{1}{10!} f^{(10)}(5)$. Expanding the given form of the Taylor polynomial:

$$\begin{aligned} T_n(x) &= \sum_{k=0}^{n/2} \frac{2k+1}{3k-9} (x-5)^{2k} \\ &= \underbrace{\frac{1}{-9}}_{k=0} + \underbrace{\frac{3}{-6}(x-5)^2}_{k=1} + \cdots + \boxed{\frac{11}{6}(x-5)^{10}}_{k=5} + \cdots + \underbrace{\frac{n+1}{(3/2)n-9}(x-5)^n}_{k=n/2} \end{aligned}$$

Equating the coefficients of $(x-5)^{10}$ in the two expressions:

$$\begin{aligned} \frac{1}{10!} f^{(10)}(5) &= \frac{11}{6} \\ f^{(10)}(5) &= \frac{11 \cdot 10!}{6} \end{aligned}$$

S-6: Since $T_3(x)$ is the third-degree Taylor polynomial for $f(x)$ about $x = a$, we know the following things to be true:

- $f(a) = T_3(a)$
- $f'(a) = T_3'(a)$
- $f''(a) = T_3''(a)$
- $f'''(a) = T_3'''(a)$

But, some of these don't look super useful. For instance, if we try to use the first bullet, we get this equation:

$$a^3 \left[2\log a - \frac{11}{3} \right] = -\frac{2}{3}\sqrt{e^3} + 3ea - 6\sqrt{ea^2} + a^3$$

Solving this would be terrible. Instead, let's think about how the equations look when we move further down the list. Since $T_3(x)$ is a cubic equation, $T_3'''(x)$ is a constant (and so $T_3'''(a)$ does not depend on a). That sounds like it's probably the simplest option. Let's start differentiating. We'll need to know both $f'''(a)$ and $T_3'''(a)$.

$$\begin{aligned} f(x) &= x^3 \left[2\log x - \frac{11}{3} \right] \\ f'(x) &= x^3 \left[\frac{2}{x} \right] + 3x^2 \left[2\log x - \frac{11}{3} \right] = 6x^2 \log x - 9x^2 \\ f''(x) &= 6x^2 \cdot \frac{1}{x} + 12x \log x - 18x = 12x \log x - 12x \\ f'''(x) &= 12x \cdot \frac{1}{x} + 12 \log x - 12 = 12 \log x \\ f'''(a) &= 12 \log a \end{aligned}$$

Now, let's move to the Taylor polynomial. Remember that e is a constant.

$$\begin{aligned} T_3(x) &= -\frac{2}{3}\sqrt{e^3} + 3ex - 6\sqrt{ex^2} + x^3 \\ T_3'(x) &= 3e - 12\sqrt{ex} + 3x^2 \\ T_3''(x) &= -12\sqrt{e} + 6x \\ T_3'''(x) &= 6 \\ T_3'''(a) &= 6 \end{aligned}$$

The final bullet point gives us the equation:

$$\begin{aligned} f'''(a) &= T_3'''(a) \\ 12 \log a &= 6 \\ \log a &= \frac{1}{2} \\ a &= e^{\frac{1}{2}} \end{aligned}$$

So, $a = \sqrt{e}$.

Solutions to Exercises 9.5 — Jump to [TABLE OF CONTENTS](#)

S-1: If we were to find the 16th degree Maclaurin polynomial for a generic function, we might expect to have to differentiate 16 times (ugh). But, we know that the derivatives of sines and cosines

repeat themselves. So, it's enough to figure out the pattern:

$$\begin{array}{ll}
 f(x) = \sin x + \cos x & f(0) = 1 \\
 f'(x) = \cos x - \sin x & f'(0) = 1 \\
 f''(x) = -\sin x - \cos x & f''(0) = -1 \\
 f'''(x) = -\cos x + \sin x & f'''(0) = -1 \\
 f^{(4)}(x) = \sin x + \cos x & f^{(4)}(0) = 1
 \end{array}$$

Since $f^{(4)}(x) = f(x)$, our derivatives repeat from here. They follow the pattern: $+1, +1, -1, -1$.

$$\begin{aligned}
 T_{16}(x) = & 1 + x - \frac{1}{2}x^2 - \frac{1}{3!}x^3 + \frac{1}{4!}x^4 + \frac{1}{5!}x^5 - \frac{1}{6!}x^6 - \frac{1}{7!}x^7 + \frac{1}{8!}x^8 + \frac{1}{9!}x^9 - \frac{1}{10!}x^{10} - \frac{1}{11!}x^{11} \\
 & + \frac{1}{12!}x^{12} + \frac{1}{13!}x^{13} - \frac{1}{14!}x^{14} - \frac{1}{15!}x^{15} + \frac{1}{16!}x^{16}
 \end{aligned}$$

S-2: A Taylor polynomial gives a polynomial approximation for a function $s(t)$. Since $s(t)$ is itself a polynomial, any n th-degree Taylor polynomial, with n greater than or equal to the degree of $s(t)$, will simply give $s(t)$. So, in our case, $T_{100}(t) = s(t) = 4.9t^2 - t + 10$.

If that isn't satisfying, you can go through the normal method of calculating $T_{100}(t)$.

$$\begin{array}{ll}
 s(t) = 4.9t^2 - t + 10 & s(5) = 4.9(25) - 5 + 10 = 127.5 \\
 s'(t) = 9.8t - 1 & s'(5) = 9.8(5) - 1 = 48 \\
 s''(t) = 9.8 & s''(5) = 9.8
 \end{array}$$

The rest of the derivatives of $s(t)$ are identically zero, so they are (in particular) zero when $t = 5$. Therefore,

$$\begin{aligned}
 T_{100}(t) &= 127.5 + 48(t-5) + \frac{1}{2}9.8(t-5)^2 \\
 &= 127.5 + 48(t-5) + 4.9(t-5)^2
 \end{aligned}$$

We can now check that $T_{100}(t)$ really is the same as $s(t)$.

$$\begin{aligned}
 T_{100}(t) &= 127.5 + 48(t-5) + 4.9(t-5)^2 \\
 &= 127.5 + 48(t-5) + 4.9(t^2 - 10t + 25) \\
 &= [127.5 + 48(-5) + 4.9(25)] + [48 - 4.9(10)]t + 4.9t^2 \\
 &= 10 - t + 4.9t^2 = s(t)
 \end{aligned}$$

as expected.

S-3: Let's start by differentiating $f(x)$ and looking for a pattern. Remember that $\log 2 = \log_e 2$ is a constant number.

$$\begin{aligned} f(x) &= 2^x \\ f'(x) &= 2^x \log 2 \\ f''(x) &= 2^x (\log 2)^2 \\ f^{(3)}(x) &= 2^x (\log 2)^3 \\ f^{(4)}(x) &= 2^x (\log 2)^4 \\ f^{(5)}(x) &= 2^x (\log 2)^5 \end{aligned}$$

So, in general,

$$f^{(k)}(x) = 2^x (\log 2)^k$$

We notice that this formula works even when $k = 0$ and $k = 1$. When $x = 1$,

$$f^{(k)}(1) = 2(\log 2)^k$$

The n th degree Taylor polynomial of $f(x)$ about $x = 1$ is

$$\begin{aligned} T_n(x) &= \sum_{k=0}^n \frac{f^{(k)}(1)}{k!} (x-1)^k \\ &= \sum_{k=0}^n \frac{2(\log 2)^k}{k!} (x-1)^k \end{aligned}$$

S-4: We need to know the first six derivatives of $f(x)$ at $x = 1$. Let's get started.

$$\begin{aligned} f(x) &= x^2 \log x + 2x^2 + 5 & f(1) &= 7 \\ f'(x) &= (x^2) \frac{1}{x} + (2x) \log x + 4x & & \\ &= 2x \log x + 5x & f'(1) &= 5 \\ f''(x) &= (2x) \frac{1}{x} + (2) \log x + 5 & & \\ &= 2 \log x + 7 & f''(1) &= 7 \\ f'''(x) &= 2x^{-1} & f'''(1) &= 2 \\ f^{(4)} &= -2x^{-2} & f^{(4)}(1) &= -2 \\ f^{(5)} &= 4x^{-3} & f^{(5)}(1) &= 4 \\ f^{(6)} &= -12x^{-4} & f^{(6)}(1) &= -12 \end{aligned}$$

Now, we can plug in.

$$\begin{aligned}T_6(x) &= f(1) + f'(1)(x-1) + \frac{1}{2}f''(1)(x-1)^2 + \frac{1}{3!}f'''(1)(x-1)^3 \\ &\quad + \frac{1}{4!}f^{(4)}(1)(x-1)^4 + \frac{1}{5!}f^{(5)}(1)(x-1)^5 + \frac{1}{6!}f^{(6)}(1)(x-1)^6 \\ &= 7 + 5(x-1) + \frac{1}{2}(7)(x-1)^2 + \frac{1}{3!}(2)(x-1)^3 \\ &\quad + \frac{1}{4!}(-2)(x-1)^4 + \frac{1}{5!}(4)(x-1)^5 + \frac{1}{6!}(-12)(x-1)^6 \\ &= 7 + 5(x-1) + \frac{7}{2}(x-1)^2 + \frac{1}{3}(x-1)^3 - \frac{1}{12}(x-1)^4 + \frac{1}{30}(x-1)^5 - \frac{1}{60}(x-1)^6\end{aligned}$$

S-5: We'll start by differentiating and looking for a pattern.

$$f(x) = \frac{1}{1-x} = (1-x)^{-1}$$

Using the chain rule,

$$\begin{aligned}f'(x) &= (-1)(1-x)^{-2}(-1) = (1-x)^{-2} \\ f''(x) &= (-2)(1-x)^{-3}(-1) = 2(1-x)^{-3} \\ f^{(3)}(x) &= (-3)(2)(1-x)^{-4}(-1) = 2(3)(1-x)^{-4} \\ f^{(4)}(x) &= (-4)(2)(3)(1-x)^{-5}(-1) = 2(3)(4)(1-x)^{-5} \\ f^{(5)}(x) &= (-5)(2)(3)(4)(1-x)^{-6}(-1) = 2(3)(4)(5)(1-x)^{-6}\end{aligned}$$

Recognizing the pattern,

$$\begin{aligned}f^{(k)}(x) &= k!(1-x)^{-(k+1)} \\ f^{(k)}(0) &= k!(1)^{-(k+1)} = k!\end{aligned}$$

The n th degree Maclaurin polynomial for $f(x)$ is

$$\begin{aligned}T_n(x) &= \sum_{k=0}^n \frac{f^{(k)}(0)}{k!} x^k \\ &= \sum_{k=0}^n \frac{k!}{k!} x^k \\ &= \sum_{k=0}^n x^k\end{aligned}$$

S-6: We'll need to know the first three derivatives of x^x at $x = 1$. This is a good review of logarithmic differentiation, covered in Section 4.4.

$$\begin{aligned}
 f(x) &= x^x & f(1) &= 1 \\
 \log(f(x)) &= \log(x^x) = x \log x \\
 \frac{d}{dx} \{\log(f(x))\} &= \frac{d}{dx} \{x \log x\} \\
 \frac{f'(x)}{f(x)} &= x \cdot \frac{1}{x} + \log x = 1 + \log x \\
 f'(x) &= x^x [1 + \log x] & f'(1) &= 1 \\
 f''(x) &= \frac{d}{dx} \{x^x\} [1 + \log x] + x^x \frac{d}{dx} \{1 + \log x\} \\
 &= (x^x [1 + \log x]) [1 + \log x] + x^x \cdot \frac{1}{x} \\
 &= x^x \left((1 + \log x)^2 + \frac{1}{x} \right) & f''(1) &= 2 \\
 f'''(x) &= \frac{d}{dx} \{x^x\} \left((1 + \log x)^2 + \frac{1}{x} \right) + x^x \frac{d}{dx} \left\{ (1 + \log x)^2 + \frac{1}{x} \right\} \\
 &= x^x [1 + \log x] \left((1 + \log x)^2 + \frac{1}{x} \right) + x^x \left[\frac{2}{x} (1 + \log x) - \frac{1}{x^2} \right] \\
 &= x^x \left((1 + \log x)^3 + \frac{3}{x} (1 + \log x) - \frac{1}{x^2} \right) & f'''(1) &= 3
 \end{aligned}$$

Now, we can plug in:

$$\begin{aligned}
 T_3(x) &= f(1) + f'(1)(x-1) + \frac{1}{2}f''(1)(x-1)^2 + \frac{1}{3!}f'''(1)(x-1)^3 \\
 &= 1 + 1(x-1) + \frac{1}{2}(2)(x-1)^2 + \frac{1}{6}(3)(x-1)^3 \\
 &= 1 + (x-1) + (x-1)^2 + \frac{1}{2}(x-1)^3
 \end{aligned}$$

S-7: We note that $6 \arctan\left(\frac{1}{\sqrt{3}}\right) = 6\left(\frac{\pi}{6}\right) = \pi$. We will find the 5th-degree Maclaurin polynomial $T_5(x)$ for $f(x) = 6 \arctan x$. Then $\pi = f\left(\frac{1}{\sqrt{3}}\right) \approx T_5\left(\frac{1}{\sqrt{3}}\right)$. Let's begin by finding

the first five derivatives of $f(x) = 6 \arctan x$.

$$\begin{aligned}
 f(x) &= 6 \arctan x & f(0) &= 0 \\
 f'(x) &= 6 \left(\frac{1}{1+x^2} \right) & f'(0) &= 6 \\
 f''(x) &= 6 \left(\frac{0-2x}{(1+x^2)^2} \right) = -12 \left(\frac{x}{(1+x^2)^2} \right) & f''(0) &= 0 \\
 f'''(x) &= -12 \left(\frac{(1+x^2)^2 - x \cdot 2(1+x^2)(2x)}{(1+x^2)^4} \right) \\
 &= -12 \left(\frac{(1+x^2) - 4x^2}{(1+x^2)^3} \right) & f'''(0) &= -12 \\
 &= -12 \left(\frac{1-3x^2}{(1+x^2)^3} \right) \\
 f^{(4)}(x) &= -12 \left(\frac{(1+x^2)^3(-6x) - (1-3x^2) \cdot 3(1+x^2)^2(2x)}{(1+x^2)^6} \right) \\
 &= -12 \left(\frac{-6x(1+x^2) - 6x(1-3x^2)}{(1+x^2)^4} \right) \\
 &= 144 \left(\frac{x-x^3}{(1+x^2)^4} \right) & f^{(4)}(0) &= 0 \\
 f^{(5)}(x) &= 144 \left(\frac{(1+x^2)^4(1-3x^2) - (x-x^3) \cdot 4(1+x^2)^3(2x)}{(1+x^2)^8} \right) \\
 &= 144 \left(\frac{(1+x^2)(1-3x^2) - 8x(x-x^3)}{(1+x^2)^5} \right) \\
 &= 144 \frac{5x^4 - 10x^2 + 1}{(1+x^2)^5} & f^{(5)}(0) &= 144
 \end{aligned}$$

We now use these values to compute the 5th-degree Maclaurin polynomial for $f(x)$.

$$\begin{aligned}
 T_5(x) &= f(0) + f'(0)x + \frac{1}{2}f''(0)x^2 + \frac{1}{3!}f'''(0)x^3 + \frac{1}{4!}f^{(4)}(0)x^4 + \frac{1}{5!}f^{(5)}(0)x^5 \\
 &= 6x - \frac{12}{6}x^3 + \frac{144}{120}x^5 \\
 &= 6x - 2x^3 + \frac{6}{5}x^5
 \end{aligned}$$

Now, if we want to approximate $f\left(\frac{1}{\sqrt{3}}\right) = 6 \arctan\left(\frac{1}{\sqrt{3}}\right) = \pi$:

$$\begin{aligned}
 \pi &= f\left(\frac{1}{\sqrt{3}}\right) \approx T_5\left(\frac{1}{\sqrt{3}}\right) = \frac{6}{\sqrt{3}} - \frac{2}{\sqrt{3}^3} + \frac{6}{5\sqrt{3}^5} \\
 &= 2\sqrt{3} \left(1 - \frac{1}{3 \cdot 3} + \frac{1}{5 \cdot 9} \right) \approx 3.156
 \end{aligned}$$

Remark: There are numerous methods for computing π to any desired degree of accuracy. Many of them use the Maclaurin expansion of $\arctan x$. In 1706 John Machin computed π to 100 decimal digits by using the Maclaurin expansion together with

$$\pi = 16 \arctan \frac{1}{5} - 4 \arctan \frac{1}{239}.$$

S-8: Let's start by differentiating, and looking for a pattern.

$$\begin{aligned} f(x) &= x(\log x - 1) & f(1) &= -1 \\ f'(x) &= x\left(\frac{1}{x}\right) + \log x - 1 = \log x & f'(1) &= 0 \\ f''(x) &= \frac{1}{x} = x^{-1} & f''(1) &= 1 \\ f^{(3)}(x) &= (-1)x^{-2} & f^{(3)}(1) &= -1 \\ f^{(4)}(x) &= (-2)(-1)x^{-3} = 2!x^{-3} & f^{(4)}(1) &= 2! \\ f^{(5)}(x) &= (-3)(-2)(-1)x^{-4} = -3!x^{-4} & f^{(5)}(1) &= -3! \\ f^{(6)}(x) &= (-4)(-3)(-2)(-1)x^{-5} = 4!x^{-5} & f^{(6)}(1) &= 4! \\ f^{(7)}(x) &= (-5)(-4)(-3)(-2)(-1)x^{-6} = -5!x^{-6} & f^{(7)}(1) &= -5! \\ f^{(8)}(x) &= (-6)(-5)(-4)(-3)(-2)(-1)x^{-7} = 6!x^{-7} & f^{(8)}(1) &= 6! \end{aligned}$$

When $k \geq 2$, making use of the fact that $0! = 1$ and $(-1)^{k-2} = (-1)^k$:

$$f^{(k)}(x) = (-1)^{k-2}(k-2)!x^{-(k-1)} \qquad f^{(k)}(1) = (-1)^k(k-2)!$$

Now we use the standard form of a Taylor polynomial. Since the first two terms don't fit the pattern, we add those outside of the sigma.

$$\begin{aligned} T_{100}(x) &= \sum_{k=0}^{100} \frac{f^{(k)}(1)}{k!} (x-1)^k \\ &= f(1) + f'(1)(x-1) + \sum_{k=2}^{100} \frac{f^{(k)}(1)}{k!} (x-1)^k \\ &= -1 + 0(x-1) + \sum_{k=2}^{100} \frac{(-1)^k(k-2)!}{k!} (x-1)^k \\ &= -1 + \sum_{k=2}^{100} \frac{(-1)^k}{k(k-1)} (x-1)^k \end{aligned}$$

S-9: Recall that

$$T_{2n}(x) = \sum_{k=0}^{2n} \frac{f^{(k)}\left(\frac{\pi}{4}\right)}{k!} \left(x - \frac{\pi}{4}\right)^k$$

Let's start by taking some derivatives. Of course, since we're differentiating sine, the derivatives

will repeat every four iterations.

$$\begin{array}{ll}
 f(x) = \sin x & f\left(\frac{\pi}{4}\right) = \frac{1}{\sqrt{2}} \\
 f'(x) = \cos x & f'\left(\frac{\pi}{4}\right) = \frac{1}{\sqrt{2}} \\
 f''(x) = -\sin x & f''\left(\frac{\pi}{4}\right) = -\frac{1}{\sqrt{2}} \\
 f'''(x) = -\cos x & f'''\left(\frac{\pi}{4}\right) = -\frac{1}{\sqrt{2}}
 \end{array}$$

So, the pattern of derivatives is $\frac{1}{\sqrt{2}}, \frac{1}{\sqrt{2}}, -\frac{1}{\sqrt{2}}, -\frac{1}{\sqrt{2}}, \frac{1}{\sqrt{2}}, \frac{1}{\sqrt{2}}, -\frac{1}{\sqrt{2}}, -\frac{1}{\sqrt{2}}$, etc. This is a little tricky to write in sigma notation. We can deal with the “doubles” by separating the even and odd powers. The first few terms of T_{2n} that contain even powers of $(x - \frac{\pi}{4})$ are

$$\underbrace{\frac{1}{\sqrt{2}}}_{k=0} - \underbrace{\frac{1}{2!\sqrt{2}}\left(x - \frac{\pi}{4}\right)^2}_{k=2} + \underbrace{\frac{1}{4!\sqrt{2}}\left(x - \frac{\pi}{4}\right)^4}_{k=4}$$

Observe that the signs alternate between successive terms. So if we rename k to 2ℓ these terms are

$$\underbrace{\frac{1}{\sqrt{2}}}_{\ell=0} - \underbrace{\frac{1}{2!\sqrt{2}}\left(x - \frac{\pi}{4}\right)^2}_{\ell=1} + \underbrace{\frac{1}{4!\sqrt{2}}\left(x - \frac{\pi}{4}\right)^4}_{\ell=2}$$

and the ℓ^{th} term here is $\frac{(-1)^\ell}{(2\ell)!\sqrt{2}}\left(x - \frac{\pi}{4}\right)^{2\ell}$. To verify that this really is the ℓ^{th} term, evaluate this for $\ell = 0, 1, 2$ explicitly. When $k = 2n$, $\ell = n$ so that

$$\sum_{\substack{0 \leq k \leq 2n \\ k \text{ even}}} \frac{f^{(k)}\left(\frac{\pi}{4}\right)}{k!} \left(x - \frac{\pi}{4}\right)^k = \sum_{\ell=0}^n \frac{(-1)^\ell}{(2\ell)!\sqrt{2}} \left(x - \frac{\pi}{4}\right)^{2\ell}$$

Now for the odd powers. The first few terms of T_{2n} that contain odd powers of $(x - \frac{\pi}{4})$ are

$$\underbrace{\frac{1}{\sqrt{2}}\left(x - \frac{\pi}{4}\right)}_{k=1} - \underbrace{\frac{1}{3!\sqrt{2}}\left(x - \frac{\pi}{4}\right)^3}_{k=3} + \underbrace{\frac{1}{5!\sqrt{2}}\left(x - \frac{\pi}{4}\right)^5}_{k=5}$$

Observe that the signs again alternate between successive terms. So if we rename k to $2\ell + 1$ these terms are

$$\underbrace{\frac{1}{\sqrt{2}}\left(x - \frac{\pi}{4}\right)}_{\ell=0} - \underbrace{\frac{1}{3!\sqrt{2}}\left(x - \frac{\pi}{4}\right)^3}_{\ell=1} + \underbrace{\frac{1}{5!\sqrt{2}}\left(x - \frac{\pi}{4}\right)^5}_{\ell=2}$$

and the ℓ^{th} term here is $\frac{(-1)^\ell}{(2\ell+1)!\sqrt{2}} \left(x - \frac{\pi}{4}\right)^{2\ell+1}$. To verify that this really is the ℓ^{th} term, evaluate this for $\ell = 0, 1, 2$ explicitly. The largest odd integer that is smaller than $2n$ is $2n - 1$ and when $k = 2n - 1 = 2\ell + 1$, $\ell = n - 1$ so that

$$\sum_{\substack{0 \leq k \leq 2n \\ k \text{ odd}}} \frac{f^{(k)}\left(\frac{\pi}{4}\right)}{k!} \left(x - \frac{\pi}{4}\right)^k = \sum_{\ell=0}^{n-1} \frac{(-1)^\ell}{(2\ell+1)!\sqrt{2}} \left(x - \frac{\pi}{4}\right)^{2\ell+1}$$

Putting the even and odd powers together

$$T_{2n}(x) = \sum_{\ell=0}^n \frac{(-1)^\ell}{(2\ell)!\sqrt{2}} \left(x - \frac{\pi}{4}\right)^{2\ell} + \sum_{\ell=0}^{n-1} \frac{(-1)^\ell}{(2\ell+1)!\sqrt{2}} \left(x - \frac{\pi}{4}\right)^{2\ell+1}$$

S-10: From Example 9.5.1 in the text, we see that the n th Maclaurin polynomial for $f(x) = e^x$ is

$$T_n(x) = \sum_{k=0}^n \frac{1}{k!} x^k = 1 + x + \frac{x^2}{2} + \frac{x^3}{3!} + \frac{x^4}{4!} + \cdots + \frac{x^n}{n!}$$

If $n = 157$ and $x = 1$,

$$T_{157}(1) = \sum_{k=0}^{157} \frac{1}{k!} = 1 + 1 + \frac{1}{2} + \frac{1}{3!} + \frac{1}{4!} + \cdots + \frac{1}{157!}$$

Although we wouldn't expect $T_{157}(1)$ to be exactly equal to e^1 , it's probably pretty close. So, we estimate

$$1 + \frac{1}{2} + \frac{1}{3!} + \frac{1}{4!} + \cdots + \frac{1}{157!} \approx e - 1$$

S-11: While you're working with sums, it's easy to mistake a constant for a function. The sum given in this question is some *number*: π is a constant, and k is an index—if you wrote out all 100 terms of this sum, there would be no letter k . So, the sum given is indeed a number, but we don't want to have to add 100 terms to get a good idea of what number it is.

From Example 9.5.3 in the text, we see that the $(2n)$ th-degree Maclaurin polynomial for $f(x) = \cos x$ is

$$T_{2n}(x) = \sum_{k=0}^n \frac{(-1)^k}{(2k)!} \cdot x^{2k}$$

If $n = 100$ and $x = \frac{5\pi}{4}$, this equation becomes

$$T_{200}\left(\frac{5\pi}{4}\right) = \sum_{k=0}^{100} \frac{(-1)^k}{(2k)!} \cdot \left(\frac{5\pi}{4}\right)^{2k}$$

So, the sum corresponds to the 200th Maclaurin polynomial for $f(x) = \cos x$ evaluated at $x = \frac{5\pi}{4}$. We should be careful to understand that $T_{200}(x)$ is *not* equal to $f(x)$, in general. However, when x is reasonably close to 0, these two functions are approximations of one another. So, we estimate

$$\sum_{k=0}^{100} \frac{(-1)^k}{2k!} \left(\frac{5\pi}{4}\right)^{2k} = T_{200}\left(\frac{5\pi}{4}\right) \approx \cos\left(\frac{5\pi}{4}\right) = -\frac{1}{\sqrt{2}}$$

Solutions to Exercises 9.6 — Jump to [TABLE OF CONTENTS](#)

S-1: From the given information,

$$|R(10)| = |f(10) - F(10)| = |-3 - 5| = |-8| = 8$$

So, (a) is false (since 8 is not less than or equal to 7), while (b), (c), and (d) are true.

Remark: $R(x)$ is the error in our approximation. As mentioned in the text, we almost never know R exactly, but we can give a bound. We don't need the tightest bound—just a reasonable one that is easy to calculate. If we were dealing with real functions and approximations, we might not know that $|R(10)| = 8$, but if we knew it was at most 9, that would be a pretty decent approximation.

Often in this section, we will make simplifying assumptions to get a bound that is easy to calculate. But, don't go overboard! It is a true statement to say that our absolute error is at most 100, but this statement would probably not be very helpful as a bound.

S-2: Equation 9.6.6 tells us that, when $T_n(x)$ is the n th degree Taylor polynomial for a function $f(x)$ about $x = a$, then

$$|f(x) - T_n(x)| = \left| \frac{f^{(n+1)}(c)}{(n+1)!} (x-a)^{n+1} \right|$$

for some c strictly between x and a . In our case, $n = 3$, $a = 0$, $x = 2$, and $f^{(4)}(c) = e^c$, so

$$\begin{aligned} |f(2) - T_3(2)| &= \left| \frac{f^{(4)}(c)}{4!} (2-0)^4 \right| \\ &= \frac{2^4}{4!} e^c = \frac{2}{3} e^c \end{aligned}$$

Since c is strictly between 0 and 2, $e^c < e^2$:

$$\leq \frac{2}{3} e^2$$

but this isn't a number we really know. Indeed: e^2 is the very number we're trying to approximate. So, we use the estimation $e < 3$:

$$< \frac{2}{3} \cdot 3^2 = 6$$

We conclude that the error $|f(2) - T_3(2)|$ is *less than* 6.

Now we'll get a more exact idea of the error using a calculator. (Calculators will also only give approximations of numbers like e , but they are generally very good approximations.)

$$\begin{aligned}|f(2) - T_3(2)| &= \left| e^2 - \left(1 + 2 + \frac{1}{2} \cdot 2^2 + \frac{1}{3!} \cdot 2^3 \right) \right| \\ &= \left| e^2 - \left(1 + 2 + 2 + \frac{4}{3} \right) \right| \\ &= \left| e^2 - \frac{19}{3} \right| \approx 1.056\end{aligned}$$

So, our actual answer was only off by about 1.

Remark: $1 < 6$, so this does not in any way contradict our bound $|f(2) - T_3(2)| < 6$.

S-3: Whenever you approximate a polynomial with a Taylor polynomial of greater or equal degree, your Taylor polynomial is *exactly the same* as the function you are approximating. So, the error is zero.

S-4: The constant approximation gives

$$\sin(33) \approx \sin(0) = 0$$

while the linear approximation gives

$$\begin{aligned}f(x) &\approx f(0) + f'(0)x \\ \sin(x) &\approx \sin(0) + \cos(0)x \\ &= x \\ \sin(33) &\approx 33\end{aligned}$$

Since $-1 \leq \sin(33) \leq 1$, the constant approximation is better. (But both are a little silly.)

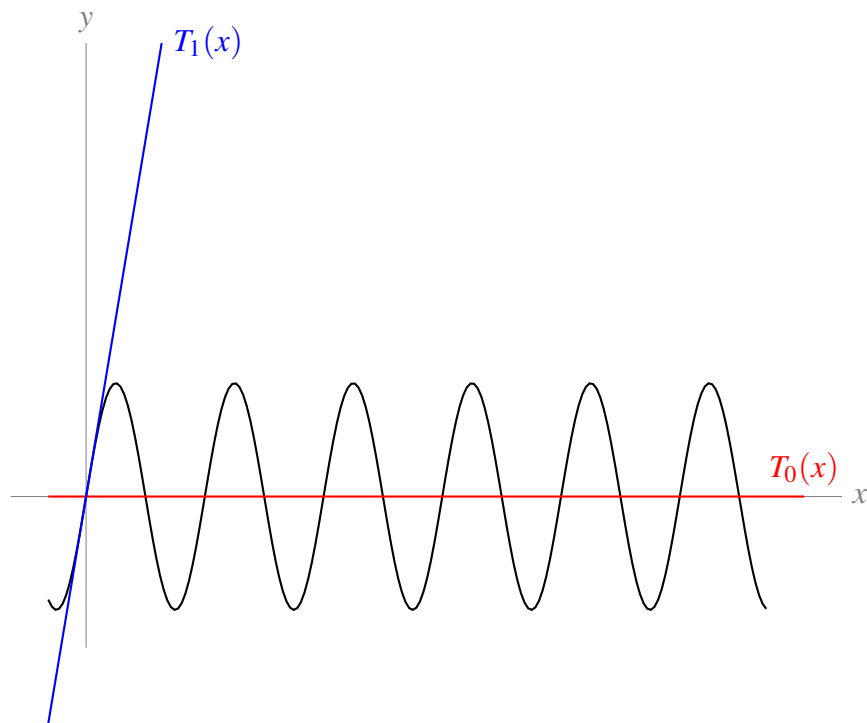

S-5: Equation 9.6.6 tells us that, when $T_n(x)$ is the n th degree Taylor polynomial for a function $f(x)$ about $x = a$, then

$$|f(x) - T_n(x)| = \left| \frac{f^{(n+1)}(c)}{(n+1)!} (x-a)^{n+1} \right|$$

for some c strictly between x and a . In our case, $n = 5$, $a = 11$, $x = 11.5$, and $f^{(6)}(c) = \frac{6!(2c-5)}{c+3}$.

$$\begin{aligned} |f(11.5) - T_5(11.5)| &= \left| \frac{1}{6!} \left(\frac{6!(2c-5)}{c+3} \right) (11.5 - 11)^6 \right| \\ &= \left| \frac{2c-5}{c+3} \right| \cdot \frac{1}{2^6} \end{aligned}$$

for some c in $(11, 11.5)$. We don't know exactly which c this is true for, but since we know that c lies in $(11, 11.5)$, we can provide bounds.

- $2c - 5 < 2(11.5) - 5 = 18$
- $c + 3 > 11 + 3 = 14$
- Therefore, $\left| \frac{2c-5}{c+3} \right| = \frac{2c-5}{c+3} < \frac{18}{14} = \frac{9}{7}$ when $c \in (11, 11.5)$.

With this bound, we see

$$\begin{aligned} |f(11.5) - T_5(11.5)| &= \left| \frac{2c-5}{c+3} \right| \cdot \frac{1}{2^6} \\ &< \left(\frac{9}{7} \right) \left(\frac{1}{2^6} \right) \approx 0.0201 \end{aligned}$$

Our error is less than 0.02.

S-6: Equation 9.6.6 tells us that, when $T_n(x)$ is the n th degree Taylor polynomial for a function $f(x)$ about $x = a$, then

$$|f(x) - T_n(x)| = \left| \frac{f^{(n+1)}(c)}{(n+1)!} (x-a)^{n+1} \right|$$

for some c strictly between x and a . In our case, $n = 2$, $a = 0$, and $x = 0.1$, so

$$\begin{aligned} |f(0.1) - T_2(0.1)| &= \left| \frac{f^{(3)}(c)}{3!} (0.1 - 0)^3 \right| \\ &= \frac{|f'''(c)|}{6000} \end{aligned}$$

for some c in $(0, 0.1)$.

We will find $f'''(x)$, and use it to give an upper bound for

$$|f(0.1) - T_2(0.1)| = \frac{|f'''(c)|}{6000}$$

when c is in $(0, 0.1)$.

$$\begin{aligned} f(x) &= \tan x \\ f'(x) &= \sec^2 x \\ f''(x) &= 2 \sec x \cdot \sec x \tan x \\ &= 2 \sec^2 x \tan x \\ f'''(x) &= (2 \sec^2 x) \sec^2 x + (4 \sec x \cdot \sec x \tan x) \tan x \\ &= 2 \sec^4 x + 4 \sec^2 x \tan^2 x \end{aligned}$$

When $0 < c < \frac{1}{10}$, also $0 < c < \frac{\pi}{6}$, so:

- $\tan c < \tan\left(\frac{\pi}{6}\right) = \frac{1}{\sqrt{3}}$
- $\cos c > \cos\left(\frac{\pi}{6}\right) = \frac{\sqrt{3}}{2}$
- $\sec c < \frac{2}{\sqrt{3}}$

With these bounds in mind for secant and tangent, we return to the expression we found for our error.

$$\begin{aligned} |f(0.1) - T_2(0.1)| &= \frac{|f'''(c)|}{6000} = \frac{|2 \sec^4 x + 4 \sec^2 x \tan^2 x|}{6000} \\ &< \frac{2 \left(\frac{2}{\sqrt{3}}\right)^4 + 4 \left(\frac{2}{\sqrt{3}}\right)^2 \left(\frac{1}{\sqrt{3}}\right)^2}{6000} \\ &= \frac{1}{1125} \end{aligned}$$

The error is less than $\frac{1}{1125}$.

S-7: Equation 9.6.6 tells us that, when $T_n(x)$ is the n th degree Taylor polynomial for a function $f(x)$ about $x = a$, then

$$|f(x) - T_n(x)| = \left| \frac{f^{(n+1)}(c)}{(n+1)!} (x-a)^{n+1} \right|$$

for some c strictly between x and a . In our case, $n = 5$, $a = 0$, and $x = -\frac{1}{4}$, so

$$\begin{aligned} \left| f\left(-\frac{1}{4}\right) - T_5\left(-\frac{1}{4}\right) \right| &= \left| \frac{f^{(6)}(c)}{6!} \left(-\frac{1}{4} - 0\right)^6 \right| \\ &= \frac{|f^{(6)}(c)|}{6! \cdot 4^6} \end{aligned}$$

for some c in $(-\frac{1}{4}, 0)$. We'll need to know the sixth derivative of $f(x)$.

$$\begin{aligned} f(x) &= \log(1-x) \\ f'(x) &= -(1-x)^{-1} \\ f''(x) &= -(1-x)^{-2} \\ f'''(x) &= -2(1-x)^{-3} \\ f^{(4)}(x) &= -3!(1-x)^{-4} \\ f^{(5)}(x) &= -4!(1-x)^{-5} \\ f^{(6)}(x) &= -5!(1-x)^{-6} \end{aligned}$$

Plugging in $|f^{(6)}(c)| = \frac{5!}{(1-c)^6}$:

$$\left| f\left(-\frac{1}{4}\right) - T_5\left(-\frac{1}{4}\right) \right| = \frac{5!}{6! \cdot 4^6 \cdot (1-c)^6} = \frac{1}{6 \cdot 4^6 \cdot (1-c)^6}$$

for some c in $(-\frac{1}{4}, 0)$.

We're interested in an upper bound for the error: we want to know the worst case scenario, so we can say that the error is *no worse* than that. We need to know what the biggest possible value of $\frac{1}{6 \cdot 4^6 \cdot (1-c)^6}$ is, given $-\frac{1}{4} < c < 0$. That means we want to know the biggest possible value of $\frac{1}{(1-c)^6}$. This corresponds to the smallest possible value of $(1-c)^6$, which in turn corresponds to the smallest absolute value of $1-c$.

- Since $-\frac{1}{4} \leq c \leq 0$, the smallest absolute value of $1-c$ occurs when $c = 0$. In other words, $|1-c| \leq 1$.
- That means the smallest possible value of $(1-c)^6$ is $1^6 = 1$.

- Then the largest possible value of $\frac{1}{(1-c)^6}$ is 1.
- Then the largest possible value of $\frac{1}{6 \cdot 4^6} \cdot \frac{1}{(1-c)^6}$ is $\frac{1}{6 \cdot 4^6} \approx 0.0000407$.

Finally, we conclude

$$\left| f\left(-\frac{1}{4}\right) - T_5\left(-\frac{1}{4}\right) \right| = \frac{1}{6 \cdot 4^6 \cdot (1-c)^6} < \frac{1}{6 \cdot 4^6} < 0.00004$$

S-8: Equation 9.6.6 tells us that, when $T_n(x)$ is the n th degree Taylor polynomial for a function $f(x)$ about $x = a$, then

$$|f(x) - T_n(x)| = \left| \frac{f^{(n+1)}(c)}{(n+1)!} (x-a)^{n+1} \right|$$

for some c strictly between x and a . In our case, $n = 3$, $a = 30$, and $x = 32$, so

$$\begin{aligned} |f(30) - T_3(30)| &= \left| \frac{f^{(4)}(c)}{4!} (30-32)^4 \right| \\ &= \frac{2}{3} |f^{(4)}(c)| \end{aligned}$$

for some c in $(30, 32)$.

We will now find $f^{(4)}(x)$. Then we can give an upper bound on $|f(30) - T_3(30)| = \frac{2}{3} |f^{(4)}(c)|$ when $c \in (30, 32)$.

$$\begin{aligned} f(x) &= x^{\frac{1}{5}} \\ f'(x) &= \frac{1}{5} x^{-\frac{4}{5}} \\ f''(x) &= -\frac{4}{5^2} x^{-\frac{9}{5}} \\ f'''(x) &= \frac{4 \cdot 9}{5^3} x^{-\frac{14}{5}} \\ f^{(4)}(x) &= -\frac{4 \cdot 9 \cdot 14}{5^4} x^{-\frac{19}{5}} \end{aligned}$$

Using this,

$$\begin{aligned} |f(30) - T_3(30)| &= \frac{2}{3} |f^{(4)}(c)| \\ &= \frac{2}{3} \left| -\frac{4 \cdot 9 \cdot 14}{5^4} c^{-\frac{19}{5}} \right| \\ &= \frac{336}{5^4 \cdot c^{\frac{19}{5}}} \end{aligned}$$

Since $30 < c < 32$,

$$\begin{aligned} &< \frac{336}{5^4 \cdot 30^{\frac{19}{5}}} = \frac{336}{5^4 \cdot 30^3 \cdot 30^{\frac{4}{5}}} \\ &= \frac{14}{5^7 \cdot 9 \cdot 30^{\frac{4}{5}}} \end{aligned}$$

This isn't a number we know. We're trying to find the error in our estimation of $\sqrt[5]{30}$, but $\sqrt[5]{30}$ shows up in our error. From here, we have to be a little creative to get a bound that actually makes sense to us. There are different ways to go about it. You could simply use $30^{\frac{4}{5}} > 1$. We will be a little more careful, and use the following estimation:

$$\begin{aligned} \frac{14}{5^7 \cdot 9 \cdot 30^{\frac{4}{5}}} &= \frac{14 \cdot 30^{\frac{1}{5}}}{5^7 \cdot 9 \cdot 30} \\ &< \frac{14 \cdot 32^{\frac{1}{5}}}{5^7 \cdot 9 \cdot 30} \\ &< \frac{14 \cdot 2}{5^7 \cdot 9 \cdot 30} \\ &< \frac{14}{5^7 \cdot 9 \cdot 15} \\ &< 0.000002 \end{aligned}$$

We conclude $|f(30) - T_3(30)| < 0.000002$.

S-9: Equation 9.6.6 tells us that, when $T_n(x)$ is the n th degree Taylor polynomial for a function $f(x)$ about $x = a$, then

$$|f(x) - T_n(x)| = \left| \frac{f^{(n+1)}(c)}{(n+1)!} (x-a)^{n+1} \right|$$

for some c strictly between x and a . In our case, $n = 1$, $a = \frac{1}{\pi}$, and $x = 0.01$, so

$$\begin{aligned} |f(0.01) - T_1(0.01)| &= \left| \frac{f''(c)}{2} \left(0.01 - \frac{1}{\pi}\right)^2 \right| \\ &= \frac{1}{2} \left(\frac{100 - \pi}{100\pi} \right)^2 \cdot |f''(c)| \end{aligned}$$

for some c in $\left(\frac{1}{100}, \frac{1}{\pi}\right)$.

Let's find $f''(x)$.

$$\begin{aligned}f(x) &= \sin\left(\frac{1}{x}\right) \\f'(x) &= \cos\left(\frac{1}{x}\right) \cdot \frac{-1}{x^2} = \frac{-\cos\left(\frac{1}{x}\right)}{x^2} \\f''(x) &= \frac{x^2 \sin\left(\frac{1}{x}\right) (-x^{-2}) + \cos\left(\frac{1}{x}\right) (2x)}{x^4} \\&= \frac{2x \cos\left(\frac{1}{x}\right) - \sin\left(\frac{1}{x}\right)}{x^4}\end{aligned}$$

Now we can plug in a better expression for $f''(c)$:

$$\begin{aligned}|f(0.01) - T_1(0.01)| &= \frac{1}{2} \left(\frac{100 - \pi}{200\pi}\right)^2 \cdot |f''(c)| \\&= \frac{1}{2} \left(\frac{100 - \pi}{100\pi}\right)^2 \cdot \frac{|2c \cos\left(\frac{1}{c}\right) - \sin\left(\frac{1}{c}\right)|}{c^4}\end{aligned}$$

for some c in $\left(\frac{1}{100}, \frac{1}{\pi}\right)$.

What we want to do now is find an upper bound on this expression containing c ,

$$\frac{1}{2} \left(\frac{100 - \pi}{100\pi}\right)^2 \cdot \frac{|2c \cos\left(\frac{1}{c}\right) - \sin\left(\frac{1}{c}\right)|}{c^4}.$$

- Since $c \geq \frac{1}{100}$, it follows that $c^4 \geq \frac{1}{100^4}$, so $\frac{1}{c^4} \leq 100^4$.
- For any value of x , $|\cos x|$ and $|\sin x|$ are at most 1. Since $|c| < 1$, also $|c \cos\left(\frac{1}{c}\right)| < |\cos\left(\frac{1}{c}\right)| \leq 1$. So, $|2c \cos\left(\frac{1}{c}\right) - \sin\left(\frac{1}{c}\right)| < 3$
- Therefore,

$$\begin{aligned}|f(0.01) - T_n(0.01)| &= \frac{1}{2} \left(\frac{100 - \pi}{100\pi}\right)^2 \cdot \frac{1}{c^4} \cdot \left|2c \cos\left(\frac{1}{c}\right) - \sin\left(\frac{1}{c}\right)\right| \\&< \frac{1}{2} \left(\frac{100 - \pi}{100\pi}\right)^2 \cdot 100^4 \cdot 3 \\&= \frac{3 \cdot 100^2}{2} \left(\frac{100}{\pi} - 1\right)^2\end{aligned}$$

Equation 9.6.6 gives the bound $|f(0.01) - T_1(0.01)| \leq \frac{3 \cdot 100^2}{2} \left(\frac{100}{\pi} - 1\right)^2$.

The bound above works out to approximately fourteen million. One way to understand why the bound is so high is that $\sin\left(\frac{1}{x}\right)$ moves about crazily when x is near zero—it moves up and down incredibly fast, so a straight line isn't going to approximate it very well at all.

That being said, because $\sin\left(\frac{1}{x}\right)$ is still “sine of something,” we know $-1 \leq f(0.01) \leq 1$. To get a better bound on the error, let’s find $T_1(x)$.

$$\begin{aligned} f(x) &= \sin\left(\frac{1}{x}\right) & f\left(\frac{1}{\pi}\right) &= \sin(\pi) = 0 \\ f'(x) &= \frac{-\cos\left(\frac{1}{x}\right)}{x^2} & f'\left(\frac{1}{\pi}\right) &= -\pi^2 \cos(\pi) = \pi^2 \end{aligned}$$

$$\begin{aligned} T_1(x) &= f\left(\frac{1}{\pi}\right) + f'\left(\frac{1}{\pi}\right)\left(x - \frac{1}{\pi}\right) \\ &= 0 + \pi^2\left(x - \frac{1}{\pi}\right) \\ &= \pi^2 x - \pi \\ T_1(0.01) &= \frac{\pi^2}{100} - \pi \end{aligned}$$

Now that we know $T_1(0.01)$, and we know $-1 \leq f(0.01) \leq 1$, we can give the bound

$$\begin{aligned} |f(0.01) - T_1(0.01)| &\leq |f(0.01)| + |T_1(0.01)| \\ &\leq 1 + \left|\frac{\pi^2}{100} - \pi\right| \\ &= 1 + \pi\left|1 - \frac{\pi}{100}\right| \\ &< 1 + \pi \\ &< 1 + 4 = 5 \end{aligned}$$

A more reasonable bound on the error is that it is less than 5.

Still more reasonably, we would not use $T_1(x)$ to evaluate $\sin(100)$ approximately. We would write $\sin(100) = \sin(100 - 32\pi)$ and approximate the right hand side, which is roughly $\sin(-\pi/6)$.

S-10: Equation 9.6.6 tells us that, when $T_n(x)$ is the n th degree Taylor polynomial for a function $f(x)$ about $x = a$, then

$$|f(x) - T_n(x)| = \left| \frac{f^{(n+1)}(c)}{(n+1)!} (x-a)^{n+1} \right|$$

for some c strictly between x and a . In our case, $n = 2$, $a = 0$, and $x = \frac{1}{2}$, so

$$\begin{aligned} \left| f\left(\frac{1}{2}\right) - T_2\left(\frac{1}{2}\right) \right| &= \left| \frac{f^{(3)}(c)}{3!} \left(\frac{1}{2} - 0\right)^3 \right| \\ &= \frac{|f^{(3)}(c)|}{3! \cdot 2^3} \end{aligned}$$

for some c in $(0, \frac{1}{2})$.

The next task that suggests itself is finding $f^{(3)}(x)$.

$$\begin{aligned}f(x) &= \arcsin x \\f'(x) &= \frac{1}{\sqrt{1-x^2}} = (1-x^2)^{-\frac{1}{2}} \\f''(x) &= -\frac{1}{2}(1-x^2)^{-\frac{3}{2}}(-2x) \\&= x(1-x^2)^{-\frac{3}{2}} \\f'''(x) &= x\left(-\frac{3}{2}\right)(1-x^2)^{-\frac{5}{2}}(-2x) + (1-x^2)^{-\frac{3}{2}} \\&= 3x^2(1-x^2)^{-\frac{5}{2}} + (1-x^2)^{-\frac{5}{2}+1} \\&= (1-x^2)^{-\frac{5}{2}}(3x^2 + (1-x^2)) \\&= (1-x^2)^{-\frac{5}{2}}(2x^2 + 1)\end{aligned}$$

Since $|f(\frac{1}{2}) - T_2(\frac{1}{2})| = \frac{|f^{(3)}(c)|}{3! \cdot 2^3}$ for some c in $(0, \frac{1}{2})$,

$$\left|f\left(\frac{1}{2}\right) - T_2\left(\frac{1}{2}\right)\right| = \frac{\left|\frac{1+2c^2}{(\sqrt{1-c^2})^5}\right|}{3! \cdot 2^3} = \frac{1+2c^2}{48(\sqrt{1-c^2})^5}$$

for some c in $(0, \frac{1}{2})$.

We want to know what is the worst case scenario-what's the biggest this expression can be. **So, now we find an upper bound on $\frac{1+2c^2}{48(\sqrt{1-c^2})^5}$ when $0 \leq c \leq \frac{1}{2}$.** Remember that our bound doesn't have to be exact, but it should be relatively easy to calculate.

- When $0 \leq c \leq \frac{1}{2}$, the biggest $1+2c^2$ can be is $1+2\left(\frac{1}{2}\right)^2 = \frac{3}{2}$.

So, the **numerator** of $\frac{1+2c^2}{48(\sqrt{1-c^2})^5}$ is at most $\frac{3}{2}$.

- The smallest $1-c^2$ can be is $1-\left(\frac{1}{2}\right)^2 = \frac{3}{4}$.

- So, the smallest $(\sqrt{1-c^2})^5$ can be is $\left(\sqrt{\frac{3}{4}}\right)^5 = \left(\frac{\sqrt{3}}{2}\right)^5$.

- Then smallest possible value for the **denominator** of $\frac{1+2c^2}{48(\sqrt{1-c^2})^5}$ is $48\left(\frac{\sqrt{3}}{2}\right)^5$

- Then

$$\begin{aligned}\frac{1+2c^2}{48(\sqrt{1-c^2})^5} &\leq \frac{\frac{3}{2}}{48\left(\frac{\sqrt{3}}{2}\right)^5} \\ &= \frac{1}{\sqrt{3}^5} = \frac{1}{9\sqrt{3}} \\ &< \frac{1}{10}\end{aligned}$$

Let's put together these pieces. We found that

$$\left|f\left(\frac{1}{2}\right) - T_2\left(\frac{1}{2}\right)\right| = \frac{1+2c^2}{48(\sqrt{1-c^2})^5}$$

for some c in $(0, \frac{1}{2})$. We also found that

$$\frac{1+2c^2}{48(\sqrt{1-c^2})^5} < \frac{1}{10}$$

when c is in $(0, \frac{1}{2})$. We conclude

$$\left|f\left(\frac{1}{2}\right) - T_2\left(\frac{1}{2}\right)\right| < \frac{1}{10}.$$

For the second part of the question, we need to find $f\left(\frac{1}{2}\right)$ and $T_2\left(\frac{1}{2}\right)$.

Finding $f\left(\frac{1}{2}\right)$ is not difficult.

$$\begin{aligned}f(x) &= \arcsin x \\ f\left(\frac{1}{2}\right) &= \arcsin\left(\frac{1}{2}\right) = \frac{\pi}{6}\end{aligned}$$

In order to find $T_2\left(\frac{1}{2}\right)$, we need to find $T_2(x)$.

$$T_2(x) = f(0) + f'(0)x + \frac{1}{2}f''(0)x^2$$

Conveniently, we've already found the first few derivatives of $f(x)$.

$$\begin{aligned}T_2(x) &= \arcsin(0) + \left(\frac{1}{\sqrt{1-0^2}}\right)x + \frac{1}{2}\left(\frac{0}{(\sqrt{1-0^2})^3}\right)x^2 \\ &= 0 + x + 0 \\ &= x \\ T_2\left(\frac{1}{2}\right) &= \frac{1}{2}\end{aligned}$$

So, the actual error is

$$\left| f\left(\frac{1}{2}\right) - T_2\left(\frac{1}{2}\right) \right| = \left| \frac{\pi}{6} - \frac{1}{2} \right| = \frac{\pi}{6} - \frac{1}{2}$$

A calculator tells us that this is about 0.02.

S-11: Our error will have the form $\frac{f^{(n+1)}(c)}{(n+1)!}(x-1)^{n+1}$ for some constant c , so let's find an equation for $f^{(n)}(x)$. This has been done before in the text, but we'll do it again here: we'll take several derivatives, then notice the pattern.

$$\begin{aligned} f(x) &= \log x \\ f'(x) &= x^{-1} \\ f''(x) &= -x^{-2} \\ f'''(x) &= 2!x^{-3} \\ f^{(4)}(x) &= -3!x^{-4} \\ f^{(5)}(x) &= 4!x^{-5} \end{aligned}$$

So, when $n \geq 1$,

$$f^{(n)}(x) = (-1)^{n-1}(n-1)! \cdot x^{-n}$$

Now that we know the derivative of $f(x)$, we have a better idea what the error in our approximation looks like.

$$\begin{aligned} |f(1.1) - T_n(1.1)| &= \left| \frac{f^{(n+1)}(c)}{(n+1)!} (1.1-1)^{n+1} \right| \\ &= \left| f^{(n+1)}(c) \right| \frac{0.1^{n+1}}{(n+1)!} \\ &= \left| \frac{n!}{c^{n+1}} \right| \frac{1}{10^{n+1}(n+1)!} \\ &= \frac{1}{|c|^{n+1} \cdot 10^{n+1} \cdot (n+1)} \end{aligned}$$

for some c in $(1, 1.1)$

$$\begin{aligned} &< \frac{1}{(n+1)10^{n+1} \cdot 1^{n+1}} \\ &= \frac{1}{(n+1)10^{n+1}} \end{aligned}$$

What we've shown so far is

$$|f(1.1) - T_n(1.1)| < \frac{1}{(n+1)10^{n+1}}$$

If we can show that $\frac{1}{(n+1)10^{n+1}} \leq 10^{-4}$, then we'll be able to conclude

$$|f(1.1) - T_n(1.1)| < \frac{1}{(n+1)10^{n+1}} \leq 10^{-4}$$

That is, our error is less than 10^{-4} .

So, our goal for the problem is to find a value of n that makes $\frac{1}{(n+1)10^{n+1}} \leq 10^{-4}$. Certainly, $n = 3$ is such a number. Therefore, any n greater than or equal to 3 is an acceptable value.

S-12: We will approximate $f(x) = x^{\frac{1}{7}}$ using a Taylor polynomial. Since $3^7 = 2187$, we will use $x = 2187$ as our centre.

We need to figure out which degree Taylor polynomial will result in a small-enough error.

If we use the n th Taylor polynomial, our error will be

$$\begin{aligned} |f(2200) - T_n(2200)| &= \left| \frac{f^{(n+1)}(c)}{(n+1)!} (2200 - 2187)^{n+1} \right| \\ &= \left| f^{(n+1)}(c) \right| \cdot \frac{13^{n+1}}{(n+1)!} \end{aligned}$$

for some c in $(2187, 2200)$. In order for this to be less than 0.001, we need

$$\begin{aligned} \left| f^{(n+1)}(c) \right| \cdot \frac{13^{n+1}}{(n+1)!} &< 0.001 \\ \left| f^{(n+1)}(c) \right| &< \frac{(n+1)!}{1000 \cdot 13^{n+1}} \end{aligned}$$

It's a tricky thing to figure out which n makes this true. Let's make a table. We won't show all the work of filling it in, but the work is standard.

n	$\frac{(n+1)!}{1000 \cdot 13^{n+1}}$	$\left f^{(n+1)}(c) \right $	Is $\left f^{(n+1)}(c) \right < \frac{(n+1)!}{1000 \cdot 13^{n+1}}$?
0	$\frac{1}{1000 \cdot 13}$	$ f'(c) = \frac{1}{7c^{6/7}} < \frac{1}{7 \cdot 3^6}$	
1	$\frac{2}{1000 \cdot 13^2}$	$ f''(c) = \frac{6}{7^2 \cdot c^{13/7}} < \frac{6}{7^2 \cdot 3^{13}}$	Yes!

That is: if we use the first-degree Taylor polynomial, then for some c between 2187 and 2200,

$$\begin{aligned} |f(2200) - T_1(2200)| &= |f''(c)| \cdot \frac{13^2}{2!} \\ &= \frac{6}{7^2 \cdot c^{\frac{13}{7}}} \cdot \frac{13^2}{2} \\ &< \frac{6}{7^2 \cdot 3^{13}} \cdot \frac{13^2}{2} \\ &= \frac{3 \cdot 13^2}{7^2 \cdot 3^{13}} \approx 0.0000065 \end{aligned}$$

So, actually, the linear Taylor polynomial (or any higher-degree Taylor polynomial) will result in an approximation that is much more accurate than required. (We don't know, however, that the constant approximation will be accurate enough—so we'd better stick with $n \geq 1$.)

Now that we know we can take the first-degree Taylor polynomial, let's compute $T_1(x)$. Recall we are taking the Taylor polynomial for $f(x) = x^{\frac{1}{7}}$ about $x = 2187$.

$$\begin{aligned} f(2187) &= 2187^{\frac{1}{7}} = 3 \\ f'(x) &= \frac{1}{7}x^{-\frac{6}{7}} \\ f'(2187) &= \frac{1}{7\sqrt[7]{2187^6}} = \frac{1}{7 \cdot 3^6} \\ T_1(x) &= f(2187) + f'(2187)(x - 2187) \\ &= 3 + \frac{x - 2187}{7 \cdot 3^6} \\ T_1(2200) &= 3 + \frac{2200 - 2187}{7 \cdot 3^6} \\ &= 3 + \frac{13}{7 \cdot 3^6} \\ &\approx 3.00255 \end{aligned}$$

We conclude $\sqrt[7]{2200} \approx 3.00255$.

S-13: If we're going to use Equation 9.6.6, then we'll probably be taking a Taylor polynomial. Using Example 9.5.5, the 6th-degree Maclaurin polynomial for $\sin x$ is

$$T_6(x) = T_5(x) = x - \frac{x^3}{3!} + \frac{x^5}{5!}$$

so let's play with this a bit. Equation 9.6.6 tells us that the error will depend on the seventh

derivative of $f(x)$, which is $-\cos x$:

$$\begin{aligned}f(1) - T_6(1) &= f^{(7)}(c) \frac{1^7}{7!} \\ \sin(1) - \left(1 - \frac{1}{3!} + \frac{1}{5!}\right) &= \frac{-\cos c}{7!} \\ \sin(1) - \frac{101}{5!} &= \frac{-\cos c}{7!} \\ \sin(1) &= \frac{4242 - \cos c}{7!}\end{aligned}$$

for some c between 0 and 1. Since $-1 \leq \cos c \leq 1$,

$$\begin{aligned}\frac{4242 - 1}{7!} &\leq \sin(1) \leq \frac{4242 + 1}{7!} \\ \frac{4241}{7!} &\leq \sin(1) \leq \frac{4243}{7!} \\ \frac{4241}{5040} &\leq \sin(1) \leq \frac{4243}{5040}\end{aligned}$$

Remark: there are lots of ways to play with this idea to get better estimates. One way is to take a higher-degree Maclaurin polynomial. Another is to note that, since $0 < c < 1 < \frac{\pi}{3}$, then

$\frac{1}{2} < \cos c < 1$, so

$$\begin{aligned}\frac{4242 - 1}{7!} < \sin(1) < \frac{4242 - \frac{1}{2}}{7!} \\ \frac{4241}{5040} < \sin(1) < \frac{8483}{10080} < \frac{4243}{5040}\end{aligned}$$

If you got tighter bounds than asked for in the problem, congratulations!

S-14: (a) For every whole number n , the n th derivative of e^x is e^x . So:

$$T_4(x) = \sum_{n=0}^4 \frac{e^0}{n!} x^n = \sum_{n=0}^4 \frac{x^n}{n!}$$

(b)

$$\begin{aligned}T_4(1) &= \sum_{n=0}^4 \frac{1^n}{n!} = \sum_{n=0}^4 \frac{1}{n!} \\ &= \frac{1}{0!} + \frac{1}{1!} + \frac{1}{2!} + \frac{1}{3!} + \frac{1}{4!} \\ &= \frac{1}{1} + \frac{1}{1} + \frac{1}{2} + \frac{1}{6} + \frac{1}{24} \\ &= \frac{65}{24}\end{aligned}$$

(c) Using Equation 9.6.6,

$$\begin{aligned}e^1 - T_4(1) &= \frac{1}{5!}e^c \quad \text{for some } c \text{ strictly between 0 and 1. So,} \\e - \frac{65}{24} &= \frac{e^c}{120} \\e &= \frac{65}{24} + \frac{e^c}{120}\end{aligned}$$

Since e^x is a strictly increasing function, and $0 < c < 1$, we conclude $e^0 < e^c < e^1$:

$$\frac{65}{24} + \frac{1}{120} < e < \frac{65}{24} + \frac{e}{120}$$

Simplifying the left inequality, we see

$$\frac{326}{120} < e$$

From the right inequality, we see

$$\begin{aligned}e &< \frac{65}{24} + \frac{e}{120} \\e - \frac{e}{120} &< \frac{65}{24} \\e \cdot \frac{119}{120} &< \frac{65}{24} \\e &< \frac{65}{24} \cdot \frac{120}{119} = \frac{325}{119}\end{aligned}$$

So, we conclude

$$\frac{326}{120} < e < \frac{325}{119},$$

as desired.

Remark: $\frac{326}{120} \approx 2.717$, and $\frac{325}{119} \approx 2.731$.

Solutions to Exercises 10 — Jump to [TABLE OF CONTENTS](#)

S-3: Before we start, we may want to get a feel for the problem with a quick sketch of $y = g(x)$. A full sketch, like we did in Chapter 7, isn't necessary (or really possible, since we don't know where the critical points are – although we can guess from the question text that there is only one critical point). But we can do a quick sketch using the ideas from Chapter 1. Namely: close to the origin, we expect $g(x) \approx x$; far from the origin, we expect $g(x) \approx -x^4$.

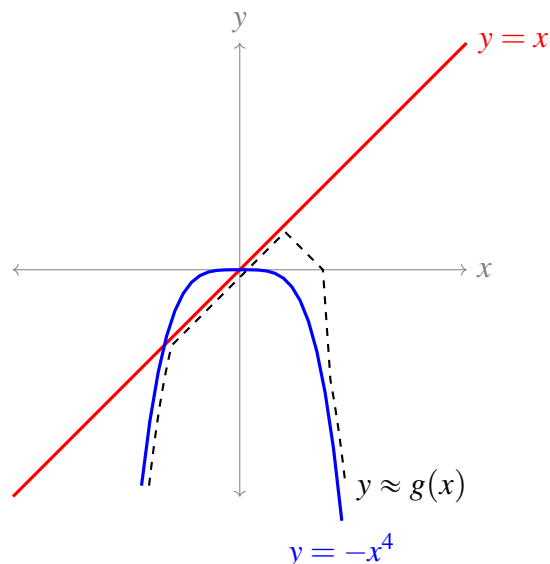

This helps us guess that our critical point should be at a positive value of x .

The critical points of the function are the roots of its derivative. So, we set

$$f(x) = g'(x) = 1 - 2x - 4x^3$$

and use Newton's Method to approximate the values of x that make $f(x)$ close to 0. The formula for refining our guess will be

$$x_{n+1} = x_n - \frac{f(x_n)}{f'(x_n)} = x_n - \frac{1 - 2x_n - 4x_n^3}{-2 - 12x_n^2} = x_n + \frac{1 - 2x_n - 4x_n^3}{2 + 12x_n^2}$$

This question doesn't tell us where to start, so we have to figure that out on our own. From our sketch, it seems small nonnegative values of x are good starting places. We'll try a few to see which are close to a root. (This is something we could also do without having first made the sketch.)

x	$f(x)$
0	1
1	-5

So it seems that $x = 0$ is a good starting point. (We also see that f changes from positive to negative somewhere between $x = 0$ and $x = 1$, so we expect our root to be somewhere between those two numbers.)

$$\begin{aligned} x_0 &= 0 \\ x_1 &= 0 + \frac{1}{2} = \frac{1}{2} \\ x_2 &= \frac{1}{2} + \frac{1 - 1 - \frac{4}{8}}{2 + 3} = \frac{1}{2} - \frac{1}{10} = \frac{2}{5} \end{aligned}$$

So, two iterations of Newton's method gives us an approximate critical point of $g(x)$ at $x = \frac{2}{5}$.

Since we know the root is between 0 and 1, we also could have started at $x = 1/2$, which would have lead to the following:

$$\begin{aligned}x_0 &= \frac{1}{2} \\x_1 &= \frac{1}{2} + \frac{1 - 1 - \frac{4}{8}}{2 + 3} = \frac{2}{5} \\x_2 &= \frac{2}{5} + \frac{1 - \frac{4}{5} - 4\left(\frac{2}{5}\right)^3}{2 + 12 \cdot \frac{4}{25}} = \frac{2}{5} - \frac{7}{5 \cdot 98} = \frac{27}{70}\end{aligned}$$

Other starting points are possible, but don't offer much benefit. Starting at $x_0 = 1$ gives us an integer starting point, which we usually go for, but it's not as good as starting at $x_0 = 0$, since $f(0)$ is closer to 0 than $f(1)$ is.

S-4: Newton's Method finds roots, so the first thing to do is to rephrase the question in terms of root finding. So, we set

$$f(x) = \arctan x - x + 10$$

and find where $f(x) = 0$.

Now, we need to find a starting place for Newton's method. That is, we should find a (preferable integer) value of x such that $f(x)$ is reasonably close to 0. Rather than use a calculator to find exact values of $\arctan x$, recall $\lim_{x \rightarrow \infty} \arctan x = \frac{\pi}{2}$. So, for large positive values of x , $\arctan x \approx \frac{\pi}{2}$. With these ideas in mind, let's start evaluating $f(x)$ at different places:

$$\begin{aligned}f(0) &= \arctan 0 - 0 + 10 = 10 && \text{This is pretty far from 0.} \\f(1) &= \arctan 1 - 1 + 10 = \frac{\pi}{4} + 9 && \text{Still pretty far from 0. Let's try bigger } x\text{'s.} \\f(9) &= \arctan 9 - 9 + 10 \approx \frac{\pi}{2} + 1 \\f(10) &= \arctan 10 - 10 + 10 \approx \frac{\pi}{2} \\f(11) &= \arctan 11 - 11 + 10 \approx \frac{\pi}{2} - 1\end{aligned}$$

Two good candidates are $x_0 = 11$ (since $\frac{\pi}{2} - 1 \approx 0.5$, which is relatively close to 0) and $x_0 = 10$ (since $f(10)$ is still relatively close to 0, but 10 is a 'rounder' number than 11.)

In both cases, the formula we'll use to get an updated approximation is

$$x_{n+1} = x_n - \frac{f(x_n)}{f'(x_n)} = x_n - \frac{\arctan x_n - x_n + 10}{\frac{1}{1+x_n^2} - 1} = x_n + \frac{(1+x_n^2)(\arctan x_n - x_n + 10)}{x_n^2}.$$

- Starting with $x_0 = 11$ would give us an approximate intersection point of

$$x_1 = 11 + \frac{122(\arctan 11 - 1)}{121}.$$

- Starting with $x_0 = 10$ would give us an approximate intersection point of

$$x_1 = 10 + \frac{101(\arctan 10)}{100}.$$

S-5: The formula we'll use is

$$x_{n+1} = x_n - \frac{x_n^3 - 12x_n + 15}{3x_n^2 - 12} = x_n - \frac{1}{3} \cdot \frac{x_n^3 - 12x_n + 15}{x_n^2 - 4}.$$

We know we want a root close to $x = 2$, so ordinarily, $x_0 = 2$ would be our choice. However, $x = 2$ is not in the domain of the function above. Geometrically, the function $f(x)$ has a horizontal tangent line at $x = 2$. Newton's method finds roots of tangent lines, but horizontal tangent lines either have no roots (as is the case here) or infinitely many roots. So, we'll need a different starting point.

The two obvious choices are $x = 1$ and $x = 3$. Note $f(1) = 4$ and $f(3) = -25$, so $x = 1$ seems like a better choice. But actually, if you start with $x = 3$, you get close to a different root. So, we'll show both below.

- Starting with $x = 1$:

$$\begin{aligned} x_0 &= 1 \\ x_1 &= 1 - \frac{1}{3} \cdot \frac{1 - 12 + 15}{1 - 4} = \frac{13}{9} \\ x_2 &= \frac{13}{9} - \frac{1}{3} \cdot \frac{\left(\frac{13}{9}\right)^3 - 12\left(\frac{13}{9}\right) + 15}{\left(\frac{13}{9}\right)^2 - 4} \end{aligned}$$

- Starting with $x = 3$:

$$\begin{aligned} x_0 &= 3 \\ x_1 &= 3 - \frac{1}{3} \cdot \frac{27 - 36 + 15}{9 - 4} = \frac{13}{5} \\ x_2 &= \frac{13}{5} - \frac{1}{3} \cdot \frac{\left(\frac{13}{5}\right)^3 - 12 \cdot \frac{13}{5} + 15}{\left(\frac{13}{5}\right)^2 - 4} \end{aligned}$$

Solutions to Exercises 11 — Jump to [TABLE OF CONTENTS](#)

Solutions to Exercises 12 — Jump to [TABLE OF CONTENTS](#)

S-21: To get from 0 to 0.03 in three steps, we use $\Delta t = 0.01 = \frac{1}{100}$.

t	y	y'
0	0	0
0.01	$0 + (0.01)(0) = 0$ $\underbrace{\hspace{1.5cm}}_{y+\Delta x \cdot y'}$	$\underbrace{0 - 0.01}_{y-t} = -0.01 = -\frac{1}{100}$
0.02	$0 + \frac{1}{100} \left(-\frac{1}{100} \right) = -\frac{1}{10^4}$ $\underbrace{\hspace{1.5cm}}_{y+\Delta x \cdot y'}$	$\underbrace{-\frac{1}{10^4} - \frac{2}{100}}_{y-t} = -\frac{201}{10^4}$
0.03	$-\frac{1}{10^4} + \frac{1}{100} \left(-\frac{201}{10^4} \right) = -\frac{301}{10^6}$ $\underbrace{\hspace{1.5cm}}_{y+\Delta x \cdot y'}$	

Note $-\frac{301}{10^6} = -0.000301$.

S-22: To get from 0 to 0.03 in three steps, we use $\Delta t = 0.01 = \frac{1}{100}$.

t	y	y'
0	0	0
0.01	$0 + (0.01)(0) = 0$ $\underbrace{\hspace{1.5cm}}_{y+\Delta x \cdot y'}$	$\underbrace{0 + 0.01}_{y+t} = 0.01 = \frac{1}{100}$
0.02	$0 + \frac{1}{100} \left(\frac{1}{100} \right) = \frac{1}{10^4}$ $\underbrace{\hspace{1.5cm}}_{y+\Delta x \cdot y'}$	$\underbrace{\frac{1}{10^4} + \frac{2}{100}}_{y+t} + \frac{201}{10^4}$
0.03	$\frac{1}{10^4} + \frac{1}{100} \left(\frac{201}{10^4} \right) = \frac{301}{10^6}$ $\underbrace{\hspace{1.5cm}}_{y+\Delta x \cdot y'}$	

Note $\frac{301}{10^6} = 0.000301$.

S-24: To get from $x = 0$ to $x = 1$ in two steps, we use $\Delta x = \frac{1}{2}$.

t	y	y'
0	0	0
$\frac{1}{2}$	$1 + \frac{1}{2}(0) = 1$ $\underbrace{\hspace{1.5cm}}_{y+\Delta x \cdot y'}$	$\underbrace{\sqrt{\frac{1}{2}}}_{\sqrt{t}}$
1	$0 + \frac{1}{2} \cdot \sqrt{\frac{1}{2}} = \frac{1}{2\sqrt{2}}$ $\underbrace{\hspace{1.5cm}}_{y+\Delta x \cdot y'}$	

S-25: To get from $x = 0$ to $x = 1$ in two steps, we'll use $\Delta x = \frac{1}{2}$.

t	y	y'
0	0	0
$\frac{1}{2}$	$0 + \frac{1}{2}(0) = 0$	0
1	$0 + \frac{1}{2}(0) = 0$	

Note: what's happened is that we chanced upon a steady state solution: the constant solution $y = 0$ is the solution to the initial value problem. So in this case, our approximation is actually exact.

S-26: To get from $x = 2$ to $x = 3$ in two steps, we'll use $\Delta x = \frac{1}{2}$.

t	y	y'
2	1	1
2.5	$1 + \frac{1}{2}(1) = \frac{3}{2}$	$\sqrt{\frac{3}{2}}$
3	$\frac{3}{2} + \frac{1}{2} \cdot \sqrt{\frac{3}{2}}$	

S-27: To get from $x = 1.1$ to $x = 1.5$ in three equal steps, each step should be $\Delta x = \frac{1.5-1.1}{3} = \frac{0.4}{3} = \frac{4}{30}$.

t	y	y'
1.1	$\frac{1}{7}$	$\frac{1/7}{1.1} = \frac{1}{7.7} = \frac{10}{77}$
$1.1 + \frac{2}{15} = \frac{3.7}{3}$	$\frac{1}{7} + \frac{2}{15} \cdot \frac{1}{7.7} = \frac{37}{231}$	$\frac{37/231}{37/30} = \frac{30}{231} = \frac{10}{77}$
$1.1 + \frac{0.8}{3} = \frac{4.1}{3}$	$\frac{37}{231} + \frac{2}{15} \cdot \frac{30}{231} = \frac{41}{231}$	$\frac{41/231}{30/41} = \frac{30}{231} = \frac{10}{77}$
$1.1 + \frac{1.2}{3} = 1.5$	$\frac{41}{231} + \frac{2}{15} \cdot \frac{30}{231} = \frac{45}{231} = \frac{15}{77}$	

Remark: the exact solution to this initial value problem is $y(t) = \frac{10}{77}t$, which is a line (and so has constant slope). Note the slopes in the table are constant as well. Furthermore, our 'approximate' value for $y(1.5)$ turns out to be the exact value of $y(1.5)$.

Solutions to Exercises 13 — Jump to [TABLE OF CONTENTS](#)

Solutions to Exercises 14.1 — Jump to [TABLE OF CONTENTS](#)

S-1:

The xz plane is filled with vertical lines; the yz plane is crosshatched; and the xy plane is solid.

The left bottom triangle vertex is $(1, 0, 0)$; the right bottom triangle vertex is $(0, 1, 0)$; the top triangle vertex is $(0, 0, 1)$.

S-2: (a) The point (x, y, z) satisfies $x^2 + y^2 + z^2 = 2x - 4y + 4$ if and only if it satisfies $x^2 - 2x + y^2 + 4y + z^2 = 4$, or equivalently $(x - 1)^2 + (y + 2)^2 + z^2 = 9$. Since $\sqrt{(x - 1)^2 + (y + 2)^2 + z^2}$ is the distance from $(1, -2, 0)$ to (x, y, z) , our point satisfies the given equation if and only if its distance from $(1, -2, 0)$ is three. So the set is the sphere of radius 3 centered on $(1, -2, 0)$.

(b) As in part (a), $x^2 + y^2 + z^2 < 2x - 4y + 4$ if and only if $(x - 1)^2 + (y + 2)^2 + z^2 < 9$. Hence our point satisfies the given inequality if and only if its distance from $(1, -2, 0)$ is strictly smaller than three. The set is the interior of the sphere of radius 3 centered on $(1, -2, 0)$.

S-3: (a) $x = y$ is a straight line and passes through the points $(0, 0)$ and $(1, 1)$. So it is the straight line through the origin that makes an angle 45° with the x - and y -axes. It is sketched in the figure on the left below.

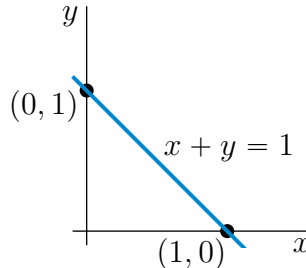
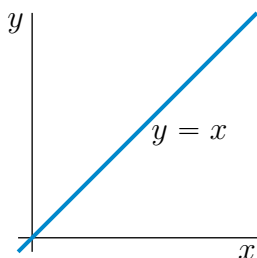

(b) $x + y = 1$ is the straight line through the points $(1, 0)$ and $(0, 1)$. It is sketched in the figure on the right above.

(c) $x^2 + y^2$ is the square of the distance from $(0, 0)$ to (x, y) . So $x^2 + y^2 = 4$ is the circle with centre $(0, 0)$ and radius 2. It is sketched in the figure on the left below.

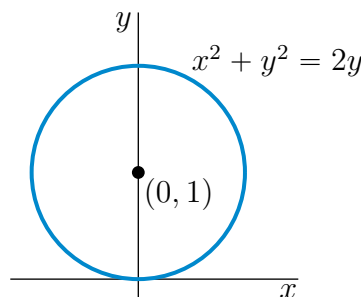
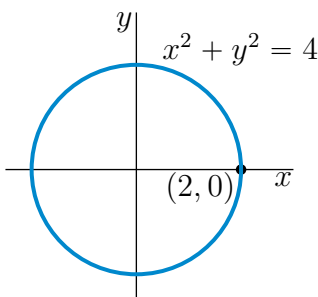

(d) The equation $x^2 + y^2 = 2y$ is equivalent to $x^2 + (y - 1)^2 = 1$. As $x^2 + (y - 1)^2$ is the square of the distance from $(0, 1)$ to (x, y) , $x^2 + (y - 1)^2 = 1$ is the circle with centre $(0, 1)$ and radius 1. It is sketched in the figure on the right above.

(e) As in part (d),

$$x^2 + y^2 < 2y \iff x^2 + y^2 - 2y < 0 \iff x^2 + y^2 - 2y + 1 < 1 \iff x^2 + (y - 1)^2 < 1$$

As $x^2 + (y - 1)^2$ is the square of the distance from $(0, 1)$ to (x, y) , $x^2 + (y - 1)^2 < 1$ is the set of points whose distance from $(0, 1)$ is strictly less than 1. That is, it is the set of points strictly inside the circle with centre $(0, 1)$ and radius 1. That set is the shaded region (not including the dashed circle) in the sketch below.

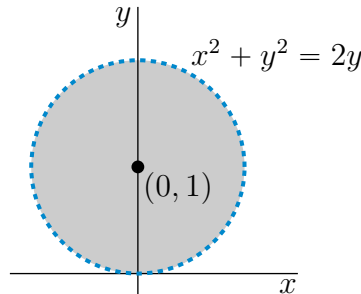

S-4: (a) For each fixed y_0 , $z = x$, $y = y_0$ is a straight line that lies in the plane, $y = y_0$ (which is parallel to the plane containing the x and z axes and is a distance y_0 from it). This line passes through $x = z = 0$ and makes an angle 45° with the xy -plane. Such a line (with $y_0 = 0$) is sketched in the figure below. The set $z = x$ is the union of all the lines $z = x$, $y = y_0$ with all values of y_0 . As y_0 varies $z = x$, $y = y_0$ sweeps out the plane which contains the y -axis and which makes an angle 45° with the xy -plane. Here is a sketch of the part of the plane that is in the first octant.

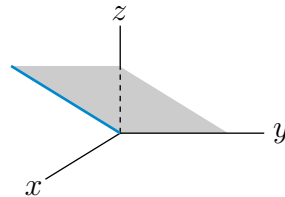

(b) $x^2 + y^2 + z^2$ is the square of the distance from $(0, 0, 0)$ to (x, y, z) . So $x^2 + y^2 + z^2 = 4$ is the set of points whose distance from $(0, 0, 0)$ is 2. It is the sphere with centre $(0, 0, 0)$ and radius 2. Here is a sketch of the part of the sphere that is in the first octant.

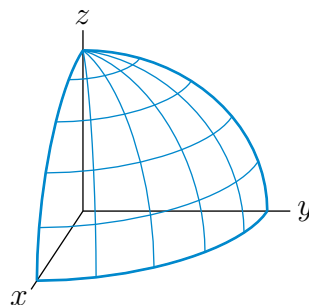

(c) $x^2 + y^2 + z^2 = 4$, $z = 1$ or equivalently $x^2 + y^2 = 3$, $z = 1$, is the intersection of the plane $z = 1$ with the sphere of centre $(0, 0, 0)$ and radius 2. It is a circle in the plane $z = 1$ that has centre $(0, 0, 1)$ and radius $\sqrt{3}$. The part of the circle in the first octant is the heavy quarter circle in the sketch

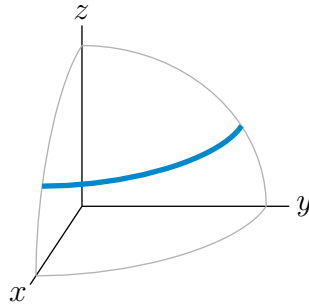

(d) For each fixed z_0 , $x^2 + y^2 = 4$, $z = z_0$ is a circle in the plane $z = z_0$ with centre $(0, 0, z_0)$ and radius 2. So $x^2 + y^2 = 4$ is the union of $x^2 + y^2 = 4$, $z = z_0$ for all possible values of z_0 . It is a vertical stack of horizontal circles. It is the cylinder of radius 2 centered on the z -axis. Here is a sketch of the part of the cylinder that is in the first octant.

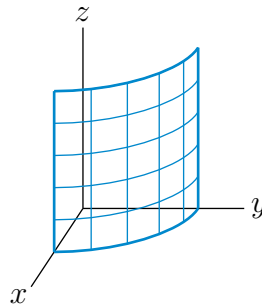

(e) For each fixed $z_0 \geq 0$, the curve $z = x^2 + y^2$, $z = z_0$ is the circle in the plane $z = z_0$ with centre $(0, 0, z_0)$ and radius $\sqrt{z_0}$. As $z = x^2 + y^2$ is the union of $z = x^2 + y^2$, $z = z_0$ for all possible values of $z_0 \geq 0$, it is a vertical stack of horizontal circles. The intersection of the surface with the yz -plane is the parabola $z = y^2$. Here is a sketch of the part of the paraboloid that is in the first octant.

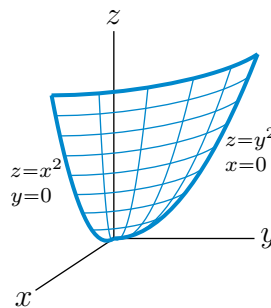

S-5: From the text, the distance from the point (x, y, z) to the point (x', y', z') is

$$\sqrt{(x - x')^2 + (y - y')^2 + (z - z')^2}$$

So, our distance is

$$\sqrt{(1 - 4)^2 + (2 - (-5))^2 + (3 - 6)^2} = \sqrt{9 + 49 + 9} = \sqrt{67}$$

S-6: From the text, the distance from the point (x, y, z) to the xy -plane is $|z|$. In this case, 9.

S-7: From the text, the distance from the point (x, y, z) to the xy -plane is $|z|$. Let the nest be the origin $(0, 0, 0)$ with the z -axis pointing north, the x -axis pointing south, and the y -axis pointing east. Then the bird's coordinates after flying are $(-1, 2, 0.1)$. So, its distance from its nest is

$$\sqrt{(-1-0)^2 + (2-0)^2 + (0.1-0)^2} = \sqrt{1+4+0.01} = \sqrt{5.01} \text{ km}$$

S-8: Let the nest be the origin $(0, 0, 0)$ with the z -axis pointing north, the x -axis pointing south, and the y -axis pointing east. From the text, the distance from the point (x, y, z) to the xy -plane (which, in this case, is the ground) is $|z|$. Then the bird's coordinates after flying are $(-2, 2, z)$. So,

$$\begin{aligned} 3 &= \sqrt{(-2-0)^2 + (2-0)^2 + (z-0)^2} = \sqrt{4+4+z^2} \\ 9 &= 8+z^2 \\ |z| &= 1 \end{aligned}$$

So, the bird is 1 km above the ground. (Or, possibly, 1 km below it.)

S-9: The first 2 km of the journey bring you 2 km away from the wall. Walking parallel to the wall neither increases nor decreases your distance to the wall. Similarly, moving vertically neither increases nor decreases your distance to the wall. So, the murder hornets are 2 km from the wall.

If we wanted to impose a coordinate system, we could place the wall as the xz axis, with z being the vertical direction, and the origin the place where you started walking. Then the murder hornets are at the point $(1, 2, 0.003)$. The distance from (x, y, z) to the xz axis is $|y|$. In this case, 2 km.

S-10: For each fixed c , the isobar $p(x, y) = c$ is the curve $x^2 - 2cx + y^2 = 1$, or equivalently, $(x - c)^2 + y^2 = 1 + c^2$. This is a circle with centre $(c, 0)$ and radius $\sqrt{1 + c^2}$, which for large c is just a bit bigger than c .

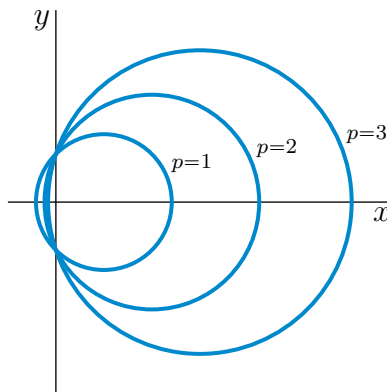

S-11: Let (x, y, z) be a point in P . The distances from (x, y, z) to $(3, -2, 3)$ and to $(3/2, 1, 0)$ are

$$\sqrt{(x-3)^2 + (y+2)^2 + (z-3)^2} \quad \text{and} \quad \sqrt{(x-3/2)^2 + (y-1)^2 + z^2}$$

respectively. To be in P , (x, y, z) must obey

$$\begin{aligned}\sqrt{(x-3)^2 + (y+2)^2 + (z-3)^2} &= 2\sqrt{(x-3/2)^2 + (y-1)^2 + z^2} \\ (x-3)^2 + (y+2)^2 + (z-3)^2 &= 4(x-3/2)^2 + 4(y-1)^2 + 4z^2 \\ x^2 - 6x + 9 + y^2 + 4y + 4 + z^2 - 6z + 9 &= 4x^2 - 12x + 9 + 4y^2 - 8y + 4 + 4z^2 \\ 3x^2 - 6x + 3y^2 - 12y + 3z^2 + 6z - 9 &= 0 \\ x^2 - 2x + y^2 - 4y + z^2 + 2z - 3 &= 0 \\ (x-1)^2 + (y-2)^2 + (z+1)^2 &= 9\end{aligned}$$

This is a sphere of radius 3 centered on $(1, 2, -1)$.

S-12: Call the centre of the circumscribing circle (\bar{x}, \bar{y}) . This centre must be equidistant from the three vertices. So

$$\bar{x}^2 + \bar{y}^2 = (\bar{x} - a)^2 + \bar{y}^2 = (\bar{x} - b)^2 + (\bar{y} - c)^2$$

or, subtracting $\bar{x}^2 + \bar{y}^2$ from the three equal expressions,

$$0 = a^2 - 2a\bar{x} = b^2 - 2b\bar{x} + c^2 - 2c\bar{y}$$

which implies

$$\bar{x} = \frac{a}{2} \quad \bar{y} = \frac{b^2 + c^2 - 2b\bar{x}}{2c} = \frac{b^2 + c^2 - ab}{2c}$$

The radius is the distance from the vertex $(0, 0)$ to the centre (\bar{x}, \bar{y}) , which is $\sqrt{\left(\frac{a}{2}\right)^2 + \left(\frac{b^2 + c^2 - ab}{2c}\right)^2}$.

S-13: The distance from P to the point $(0, 0, 1)$ is $\sqrt{x^2 + y^2 + (z-1)^2}$. The distance from P to the specified plane is $|z+1|$. Hence the equation of the surface is

$$x^2 + y^2 + (z-1)^2 = (z+1)^2 \text{ or } x^2 + y^2 = 4z$$

All points on this surface have $z \geq 0$. The set of points on the surface that have any fixed value, $z_0 \geq 0$, of z consists of a circle that is centred on the z -axis, is parallel to the xy -plane and has radius $2\sqrt{z_0}$. The surface consists of a stack of these circles, starting with a point at the origin and with radius increasing vertically. The surface is a paraboloid and is sketched below.

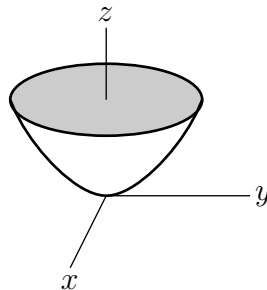

S-1: Any constant function will do. For example, $f(x,y) = 0$ or $f(x,y) = 1$.

S-2:

- (a) The range of $f(x)$ is $[-10, 10]$, since these are the y -values in the sketch.
- (b) The range of $g(x)$ is $[0, 1]$, since these are the y -values in the sketch.
- (c) In order for $f(g(x))$ to be defined, we require $-1 \leq g(x) \leq 1$. That is, the range of g must be in the domain of f . This is true for all values of $g(x)$, so there is no extra domain restriction. The domain of $f(g(x))$ is $[-1, 1]$.
- (d) Since the range of $g(x)$ is $[0, 1]$, the numbers that get plugged into f in the compound function $f(g(x))$ are only the numbers $[0, 1]$. So, the range of this function is $[0, 10]$. $g(x)$ never spits out any negative values, so $f(x)$ is restricted to the nonnegative part of its domain.

Remark: because we're going off imprecise sketches, it wouldn't be wrong to give open intervals, rather than closed intervals, as your answers.

S-3: If $x = 1 = y$, and (x,y,z) is a point on the function, then:

$$\begin{aligned}1 &= z^2(1^3) + z(1^3) + (1)(1) \\0 &= z^2 + z \\0 &= z \text{ or } -1 = z\end{aligned}$$

So yes, $(1, 1)$ is in the domain.

There's some fine print here. There are two different values of z corresponding to the input $(x,y) = (1, 1)$. That means that globally, z isn't a function of x and y , because a function should only ever have at most one output for any one input. Implicitly-defined functions often have this characteristic: it's not possible to write $z = f(x,y)$ for any single function f of x and y .

S-4: The only part of the function that could possibly limit the domain is the square root: we must not try to take the square root of a negative number.

The expression $4x^2 + y^2$ gives nonnegative numbers for any real values of x and y . So no matter what (x,y) we input, there is no danger of taking the square root of a negative number. So, the domain is all of \mathbb{R}^2 .

We've already noted that $4x^2 + y^2$ will give us numbers from $[0, \infty)$, but we should check whether it gives us *all* of those numbers. Indeed, if we set $x = 0$, we see

$$f(0,y) = \sqrt{y^2} = |y|$$

the range of which is $[0, \infty)$.

So by choosing $x = 0$ and the appropriate y , we can indeed get $f(x,y)$ to be any nonnegative number we desire. So, the range of f is $[0, \infty)$.

S-5: The only restriction on our domain is that we can't divide by 0, and $1 + y^2$ is never 0. So, our domain is all of \mathbb{R}^2 .

Since $x^2 \geq 0$ and $1 + y^2 \geq 0$, we see first that $h(x,y)$ is never negative. The question now is whether it can actually achieve all nonnegative real values. If we set $y = 0$, then $h(x,0) = x^2$, which has range $[0, \infty)$. So we can indeed find a point $h(x,y) = h(x,0)$ equal to any nonnegative number our hearts desire. That is, the range of $h(x,y)$ is $[0, \infty)$.

S-6: Recall the domain of the function $\arcsin(x)$ is $[-1, 1]$, and its range is $[-\frac{\pi}{2}, \frac{\pi}{2}]$.

Since we can only put numbers from $[-1, 1]$ into arcsine, we require for our domain

$$-1 \leq x^2 + y^2 \leq 1$$

The left part of the inequality isn't hard, since $x^2 + y^2$ is never negative. The right side tells us

$$x^2 + y^2 \leq 1$$

i.e. (x,y) is inside (or on) the unit circle.

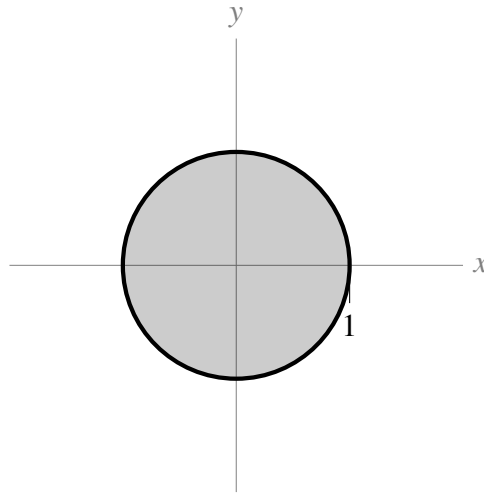

Subject to the constraint $x^2 + y^2 \leq 1$, the domain of $x^2 + y^2$ is $[0, 1]$. The range of $\arcsin x$ subject to the constraint $0 \leq x \leq 1$ is $[0, \frac{\pi}{2}]$.

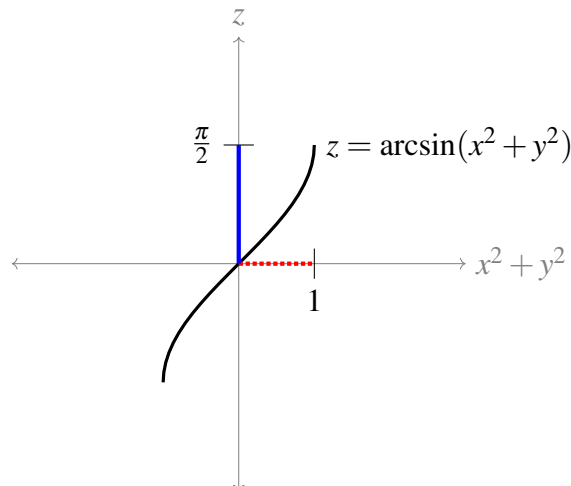

Red dotted line: range of $x^2 + y^2$ subject to restrictions.

Blue solid line: range of $\arcsin(x^2 + y^2)$.

S-7: To find the domain of g , there are two potential limiting issues: we can't divide by 0, and we can't take the logarithm of a nonpositive number.

- Since we can't divide by 0, $\log(xy) \neq 0$, which means $xy \neq 1$, or (equivalently) $y \neq \frac{1}{x}$.
- Since we can't take the logarithm of a nonpositive number, we need $xy > 0$. That is, x and y must be both negative, or both positive.

Combining these two restrictions, the domain of $g(x,y)$ is all points (x,y) such that x and y have the same sign; they are nonzero; and $y \neq \frac{1}{x}$. These points are graphed below. Dashed lines indicate points that are *not* in the domain.

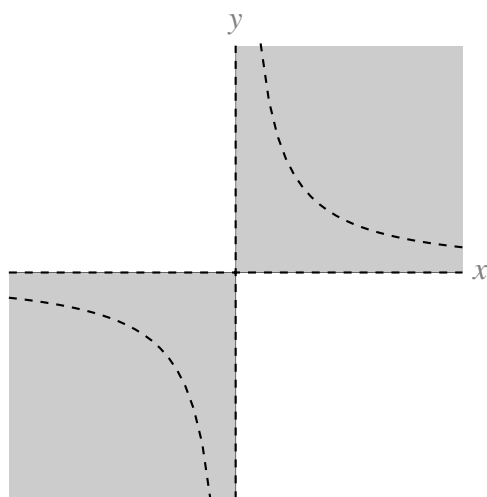

With these restrictions, xy can be *any* nonnegative number except 1; which means $\log(xy)$ can be any real number except 0; and finally the range of the entire function is $(-\infty, 0) \cup (0, \infty)$. (This is illustrated in graphs below.)

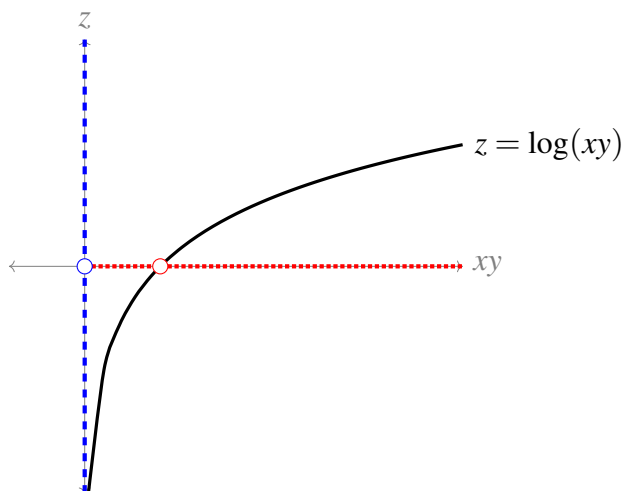

Red dotted line: values of xy . Blue dashed line: values of $\log(xy)$

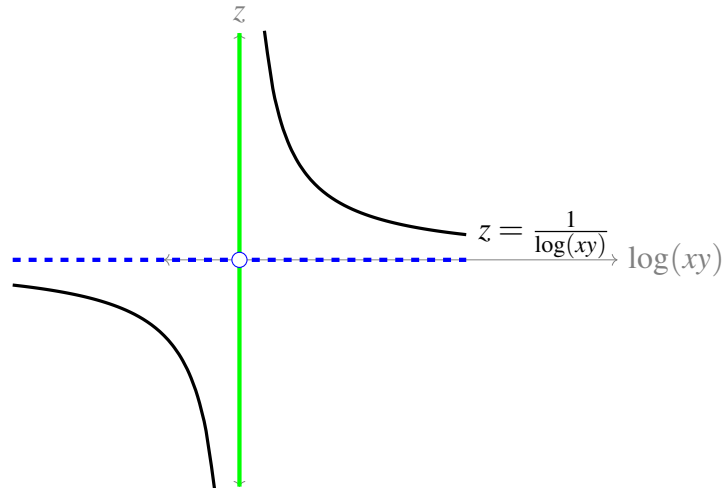

Blue dashed line: values of $\log(xy)$. Green solid line: values of $\frac{1}{\log(xy)}$

S-8: The only thing that might limit the domain of this function is dividing by zero; but since $x^2 + 1 > 0$ for all real values of x , we see the domain of f is the entire plane \mathbb{R}^2 .

Since y doesn't impact the value of f , we can consider the single-variable function

$$g(x) = \frac{x^2}{x^2 + 1}$$

Since $f(x,y) = g(x)$ for any (x,y) , the range of g will be the same as the range of f . Note $g(x)$ is continuous over all real numbers. So, its range will be (global min) $\leq g(x) \leq$ (global max). To help picture how $g(x)$ behaves, note further that $z = g(x)$ has a horizontal asymptote at $z = 1$, and $g(x)$ is an even function. Let's find the critical points of $g(x)$.

$$g'(x) = \frac{(x^2 + 1)(2x) - x^2(2x)}{(x^2 + 1)^2} = \frac{2x}{(x^2 + 1)^2}$$

The only CP of this function is $x = 0$. Its horizontal asymptotes are 1 in both directions. So, the basic shape of the function is:

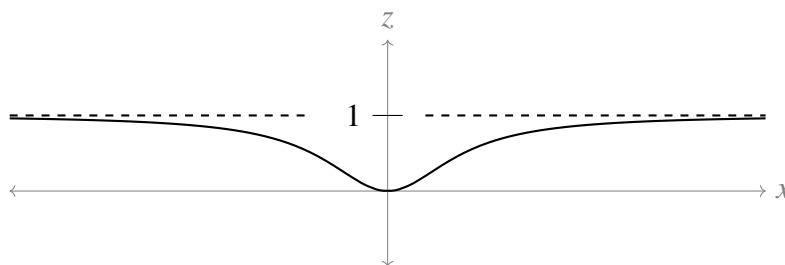

So, its range is $[0, 1)$.

S-9: The domain of $f(x,y)$ is all of \mathbb{R}^2 : the only possible restriction is dividing by zero, but $x^2 + 1 > 0$ for all values of x .

We can write $f(x,y)$ as

$$f(x,y) = f_1(x) + f_2(y)$$

where $f_1(x) = \frac{x}{x^2+1}$ and $f_2(y) = \sin y$. Since there is not term depending on both x and y , the maximum value of f will occur when x maximizes f_1 and y maximizes f_2 . Similarly, the minimum value of f will occur when x minimizes f_1 and y minimizes f_2 . Since these two functions are both continuous, we see that the range of f will be

$$(\min \text{ of } f_1 + \min \text{ of } f_2) \leq f(x,y) \leq (\max \text{ of } f_1 + \max \text{ of } f_2)$$

The range of $f_2(y) = \sin y$ is easy: it's $[-1, 1]$. Let's consider $f_1(x) = \frac{x}{x^2+1}$. Note its horizontal asymptotes are 0 in both directions, and it's an odd function. To find its extrema, let's sketch it, starting by finding its critical points.

$$f_1'(x) = \frac{(x^2+1)(1) - x(2x)}{(x^2+1)^2} = \frac{1-x^2}{(x^2+1)^2} = \frac{(1+x)(1-x)}{(x^2+1)^2}$$

The CPs of f_1 are $x = 1$ and $x = -1$.

$$f_1(1) = \frac{1}{1^2+1} = \frac{1}{2}$$

$$f_1(-1) = \frac{-1}{(-1)^2+1} = -\frac{1}{2}$$

To sketch f_1 , let's find the sign of its first derivative on the intervals between its critical points.

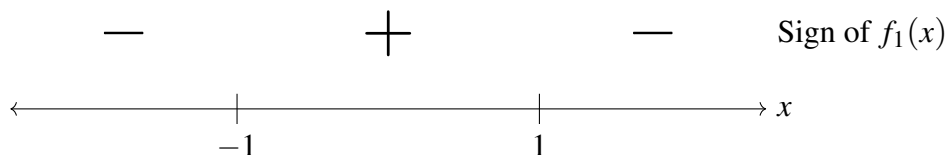

Now we have enough information to sketch $z = f_1(x)$:

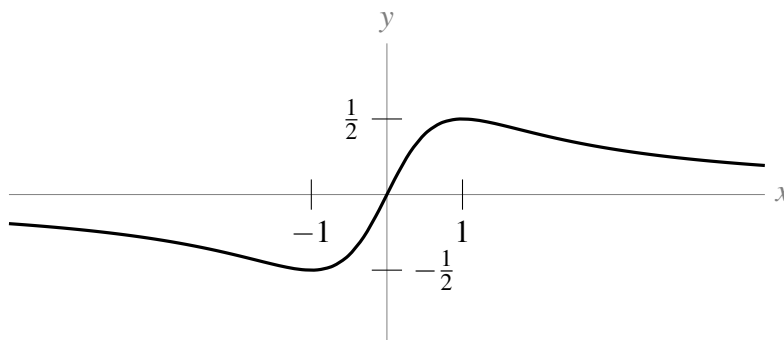

So, the range of $f_1(x)$ is $[-\frac{1}{2}, \frac{1}{2}]$.

All together, the range of $f(x,y)$ is $[-\frac{3}{2}, \frac{3}{2}]$.

S-10: Some general assumptions might be that the amount of money spend on advertisements shoudn't be negative, so we should have $a \geq 0$. Similarly, it's reasonable to assume that the company is not giving away its product, nor paying people to take it, so $p > 0$. Finally, people won't demand a negative number of goods, so the range should be nonnegative.

That is one way of thinking about the problem, but different models might have different restrictions. For example, from time to time (including a time in 2020) oil futures trade at negative values:

people were paying to give them away. So for certain models, negative prices and negative demands do make sense.

For other models, also an upper bound of some sort probable makes sense. Maybe you aren't able to sell more than one million of your product, because you don't have the capacity to manufacture more. Maybe demand will never exceed one product per person in your area. Such restrictions would further impact the domain and range that make sense for your model.

S-11: For this question, we solve two inequalities.

$$3 \leq \frac{1}{x^2 + y^2}$$
$$\implies \frac{1}{3} \geq x^2 + y^2$$

$$5 \geq \frac{1}{x^2 + y^2}$$
$$\implies \frac{1}{5} \leq x^2 + y^2$$

So, the points (x, y) must be both:

- inside or on the circle centred at the origin with radius $\frac{1}{\sqrt{3}}$, and
- not inside the circle centred at the origin with radius $\frac{1}{\sqrt{5}}$.

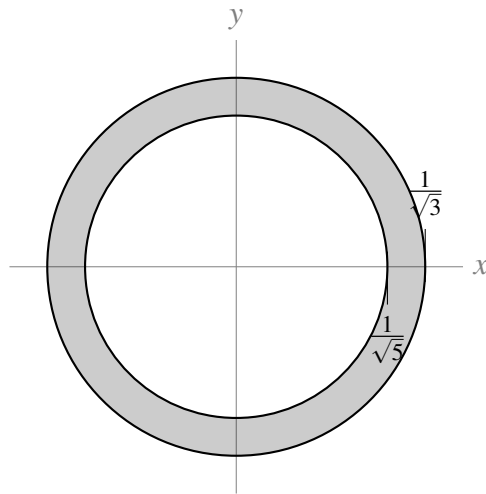

S-12: The bracketing in the definition of $g(x, y)$ is suggestive. If we define $t = x^2 - y$, then we get the function

$$h(t) = 72t^2 - t^4$$

This is easy enough to graph using tools from last semester.

- h is an even function
- $\lim_{t \rightarrow \infty} h(t) = -\infty$

- $h'(t) = 144t - 4t^3 = 4t(36 - t^2) = 4t(6 + t)(6 - t)$, so critical points are at $t = 0$ and $t = \pm 6$
- $h'(t)$ is negative on $(-6, 0) \cup (6, \infty)$ and positive on $(-\infty, -6) \cup (0, 6)$.
- The absolute maximum of $h(t)$ is $h(-6) = h(6) = 6^4 = 1296$, and $h(0) = 0$ is a local minimum.

Sketched below is $z = 72t^2 - t^4$, with parts in the model range highlighted.

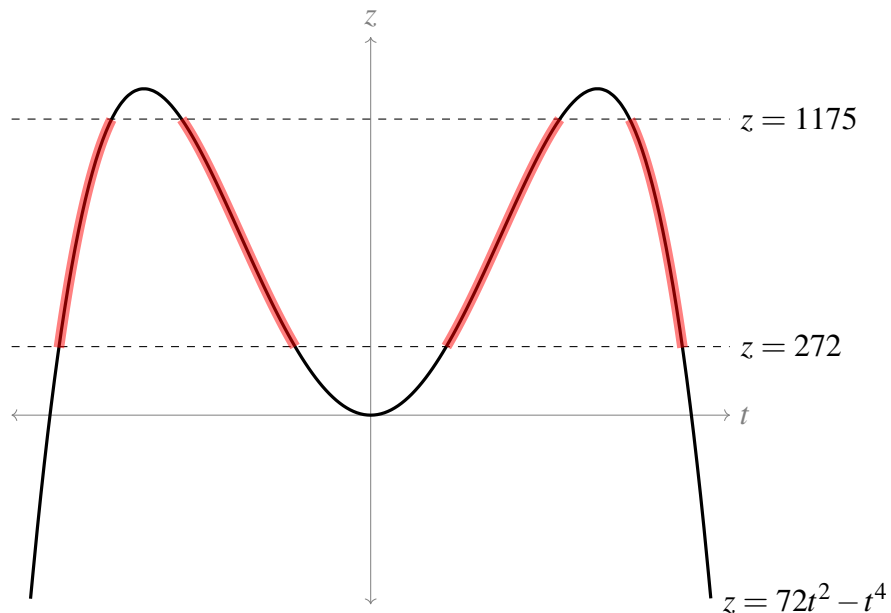

To find the t -values that correspond to the model range, we solve:

$$\begin{aligned}
 72t^2 - t^4 &= 1175 \\
 0 &= t^4 - 72t^2 + 1175 \\
 t^2 &= \frac{72 \pm \sqrt{72^2 - 4(1)(1175)}}{2} \\
 &= \frac{72 \pm \sqrt{4(36^2) - 4(1175)}}{2} \\
 &= \frac{72 \pm 2\sqrt{36^2 - 1175}}{2} \\
 &= 36 \pm \sqrt{36^2 - 1175} \\
 &= 36 \pm \sqrt{121} \\
 &= 36 \pm 11 \\
 &= 25 \text{ or } 47 \\
 t &= \pm 5 \text{ or } \pm \sqrt{47}
 \end{aligned}$$

Similarly,

$$\begin{aligned}72t^2 - t^4 &= 272 \\0 &= t^4 - 72t^2 + 272 \\t^2 &= \frac{72 \pm \sqrt{72^2 - 4(1)(272)}}{2} \\&= \frac{72 \pm \sqrt{4(36^2) - 4(272)}}{2} \\&= \frac{72 \pm 2\sqrt{36^2 - 272}}{2} \\&= 36 \pm \sqrt{36^2 - 272} \\&= 36 \pm \sqrt{1024} \\&= 36 \pm 32 \\&= 4 \text{ or } 68 \\t &= \pm 2 \text{ or } \pm \sqrt{68}\end{aligned}$$

So, now we can fill in our sketch with t -values:

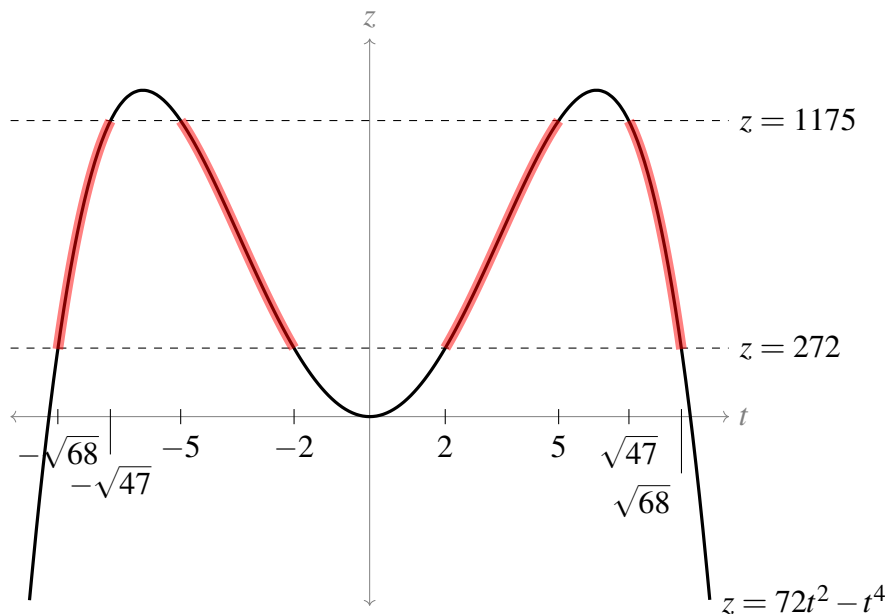

So we need to have t in $[-\sqrt{68}, -\sqrt{47}] \cup [-5, -2] \cup [2, 5] \cup [\sqrt{47}, \sqrt{68}]$.

Now, recall we used $t = x^2 - y$. So if we have $a \leq t \leq b$, then this gives us two inequalities:

$$\begin{aligned}t &\leq b \\ \implies x^2 - y &\leq b \\ \implies x^2 - b &\leq y\end{aligned}$$

and

$$\begin{aligned}t &\geq a \\ \implies x^2 - y &\geq a \\ \implies x^2 - a &\geq y\end{aligned}$$

So, t in the interval $[a, b]$ implies that (x, y) must satisfy $x^2 - b \leq y \leq x^2 - a$:

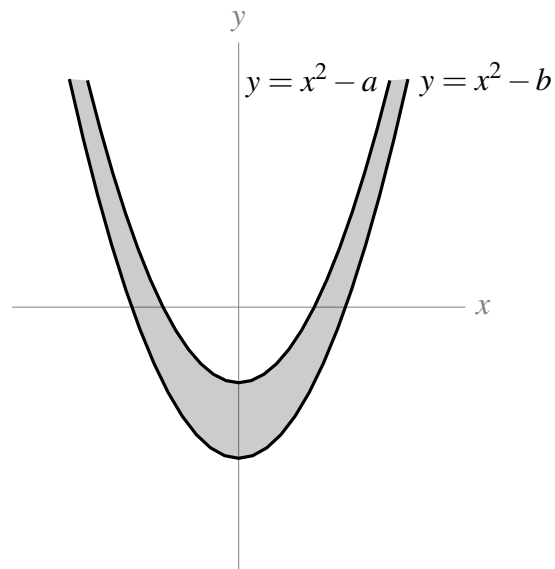

We have four such possible intervals. All together, the point (x, y) must be in one of the following regions:

- $x^2 - \sqrt{68} \leq y \leq x^2 - \sqrt{47}$
- $x^2 - 5 \leq y \leq x^2 - 2$
- $x^2 + 2 \leq y \leq x^2 + 5$
- $x^2 + \sqrt{47} \leq y \leq x^2 + \sqrt{68}$

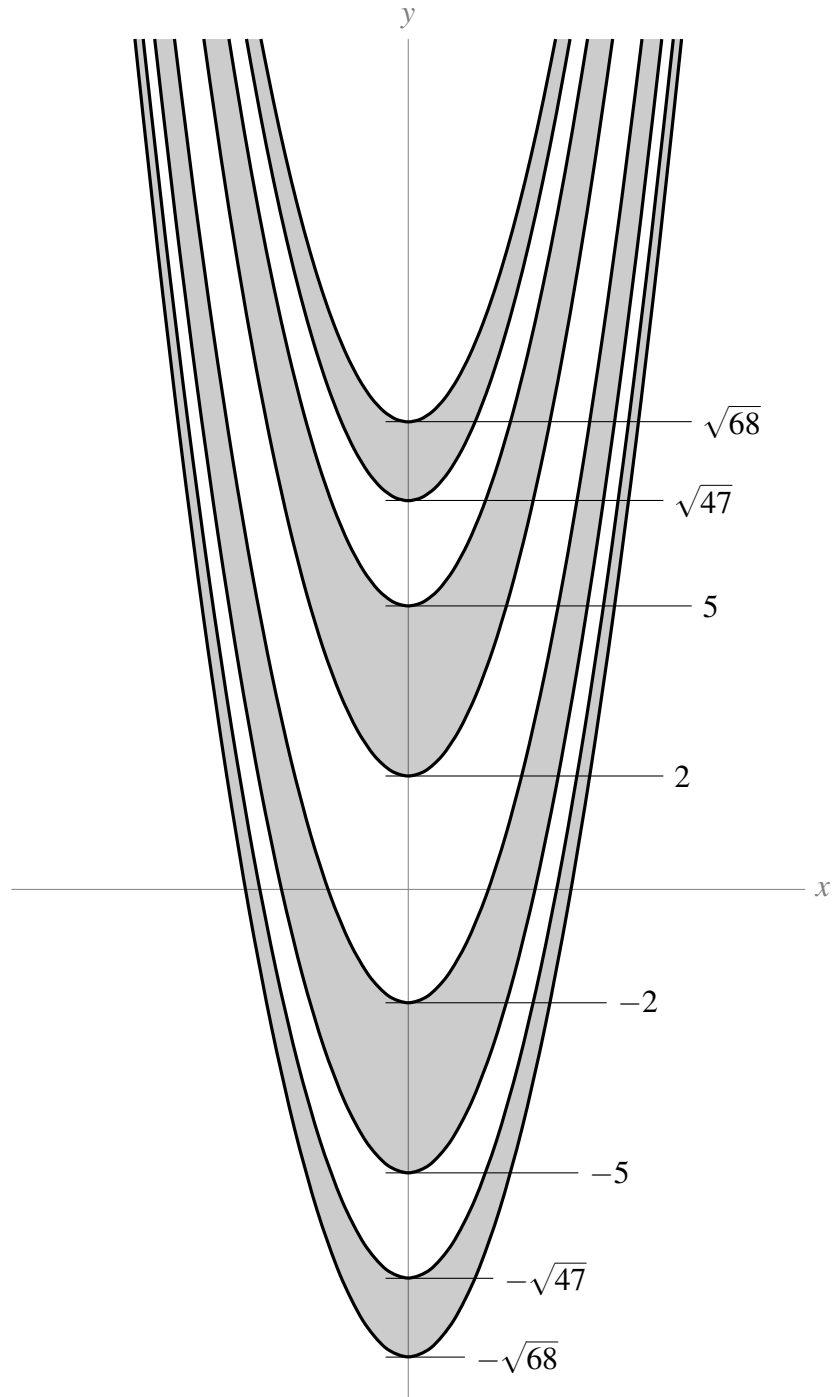

Solutions to Exercises 14.3 — Jump to [TABLE OF CONTENTS](#)

S-1:

(a) Each constant z cross-section of $x^2 + y^2 = z^2 + 1$ is a (horizontal) circle centred on the z -axis. The radius of the circle is 1 when $z = 0$ and grows as z moves away from $z = 0$. So $x^2 + y^2 = z^2 + 1$ consists of a bunch of (horizontal) circles stacked on top of each other, with the radius increasing with $|z|$. It is a hyperboloid of one sheet. The picture that corresponds to (a) is (B).

(b) Every point of $y = x^2 + z^2$ has $y \geq 0$. Only (A) has that property. We can also observe that every constant y cross-section is a circle centred on $x = z = 0$. The radius of the circle is zero when $y = 0$ and increases as y increases. The surface $y = x^2 + z^2$ is a paraboloid. The picture that corresponds to (b) is (A).

(c) The only possibility left is that the picture that corresponds to (c) is (C).

S-2: We first add into the sketch of the graph the horizontal planes $z = C$, for $C = 3, 2, 1, 0.5, 0.25$.

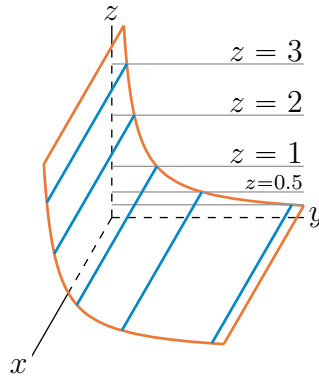

To reduce clutter, for each C , we have drawn in only

- the (gray) intersection of the horizontal plane $z = C$ with the yz -plane, i.e. with the vertical plane $x = 0$, and
- the (blue) intersection of the horizontal plane $z = C$ with the graph $z = f(x, y)$.

We have also omitted the label for the plane $z = 0.25$.

The intersection of the plane $z = C$ with the graph $z = f(x, y)$ is line

$$\{ (x, y, z) \mid z = f(x, y), z = C \} = \{ (x, y, z) \mid f(x, y) = C, z = C \}$$

Drawing this line (which is parallel to the x -axis) in the xy -plane, rather than in the plane $z = C$, gives a level curve. Doing this for each of $C = 3, 2, 1, 0.5, 0.25$ gives five level curves.

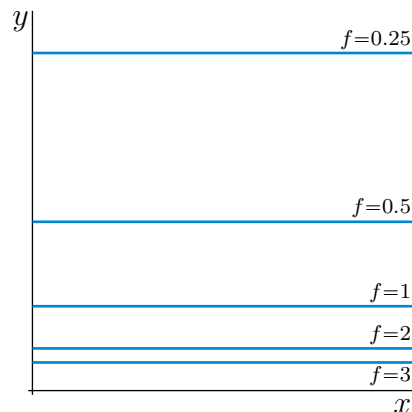

S-3: (a) For each fixed $c > 0$, the level curve $x^2 + 2y^2 = c$ is the ellipse centred on the origin with x semi axis \sqrt{c} and y semi axis $\sqrt{c}/2$. If $c = 0$, the level curve $x^2 + 2y^2 = c = 0$ is the single point $(0, 0)$.

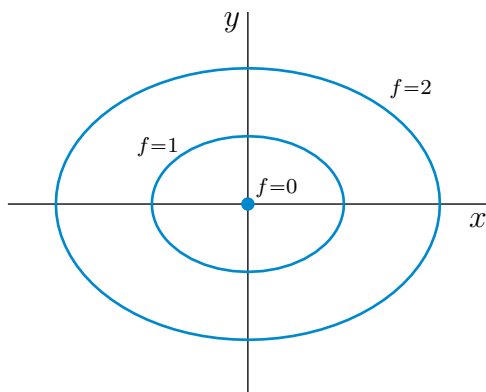

(b) For each fixed $c \neq 0$, the level curve $xy = c$ is a hyperbola centred on the origin with asymptotes the x - and y -axes. If $c > 0$, any x and y obeying $xy = c > 0$ are of the same sign. So the hyperbola is contained in the first and third quadrants. If $c < 0$, any x and y obeying $xy = c < 0$ are of opposite sign. So the hyperbola is contained in the second and fourth quadrants. If $c = 0$, the level curve $xy = c = 0$ is the single point $(0,0)$.

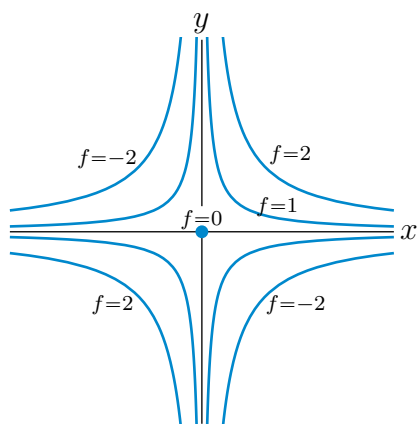

(c) For each fixed $c \neq 0$, the level curve $xe^{-y} = c$ is the logarithmic curve $y = -\ln \frac{c}{x}$. Note that, for $c > 0$, the curve

- is restricted to $x > 0$, so that $\frac{c}{x} > 0$ and $\ln \frac{c}{x}$ is defined, and that
- as $x \rightarrow 0^+$, y goes to $-\infty$, while
- as $x \rightarrow +\infty$, y goes to $+\infty$, and
- the curve crosses the x -axis (i.e. has $y = 0$) when $x = c$.

and for $c < 0$, the curve

- is restricted to $x < 0$, so that $\frac{c}{x} > 0$ and $\ln \frac{c}{x}$ is defined, and that
- as $x \rightarrow 0^-$, y goes to $-\infty$, while
- as $x \rightarrow -\infty$, y goes to $+\infty$, and
- the curve crosses the x -axis (i.e. has $y = 0$) when $x = c$.

If $c = 0$, the level curve $xe^{-y} = c = 0$ is the y -axis, $x = 0$.

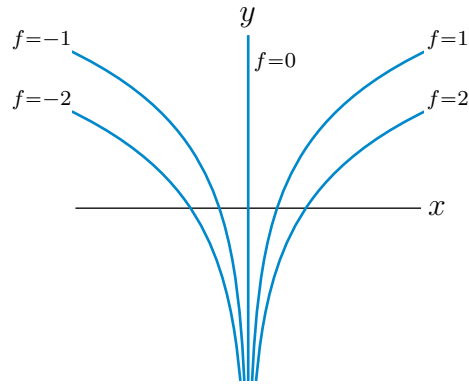

S-4: If $C = 0$, the level curve $f = C = 0$ is just the line $y = 0$. If $C \neq 0$ (of either sign), we may rewrite the equation, $f(x,y) = \frac{2y}{x^2+y^2} = C$, of the level curve $f = C$ as

$$x^2 - \frac{2}{C}y + y^2 = 0 \iff x^2 + \left(y - \frac{1}{C}\right)^2 = \frac{1}{C^2}$$

which is the equation of the circle of radius $\frac{1}{|C|}$ centred on $(0, \frac{1}{C})$.

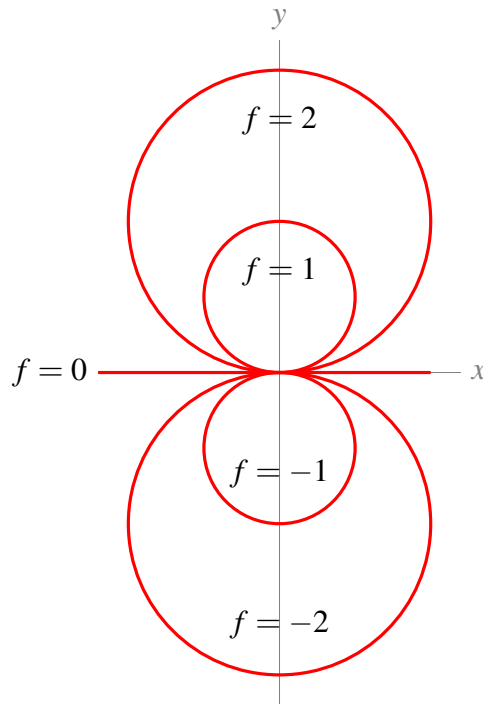

Remark. To be picky, the function $f(x,y) = \frac{2y}{x^2+y^2}$ is not defined at $(x,y) = (0,0)$. The question should have either specified that the domain of f excludes $(0,0)$ or have specified a value for $f(0,0)$. In fact, it is impossible to assign a value to $f(0,0)$ in such a way that $f(x,y)$ is continuous at $(0,0)$, because $\lim_{x \rightarrow 0} f(x,0) = 0$ while $\lim_{y \rightarrow 0} f(0,|y|) = \infty$. So it makes more sense to have the domain of f being \mathbb{R}^2 with the point $(0,0)$ removed. That's why there is a little hole at the origin in the above sketch.

S-5: (a) We can rewrite the equation as

$$x^2 + y^2 = (z-1)^2 - 1$$

The right hand side is negative for $|z - 1| < 1$, i.e. for $0 < z < 2$. So no point on the surface has $0 < z < 2$. For any fixed z , outside that range, the curve $x^2 + y^2 = (z - 1)^2 - 1$ is the circle of radius $\sqrt{(z - 1)^2 - 1}$ centred on the z -axis. That radius is 0 when $z = 0, 2$ and increases as z moves away from $z = 0, 2$. For very large $|z|$, the radius increases roughly linearly with $|z|$. Here is a sketch of some level curves.

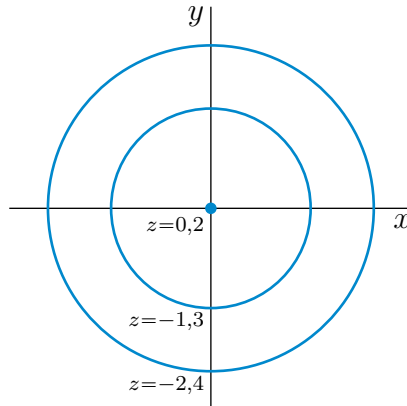

(b) The surface consists of two stacks of circles. One stack starts with radius 0 at $z = 2$. The radius increases as z increases. The other stack starts with radius 0 at $z = 0$. The radius increases as z decreases. This surface is a hyperboloid of two sheets. Here are two sketches. The sketch on the left is of the part of the surface in the first octant. The sketch on the right of the full surface.

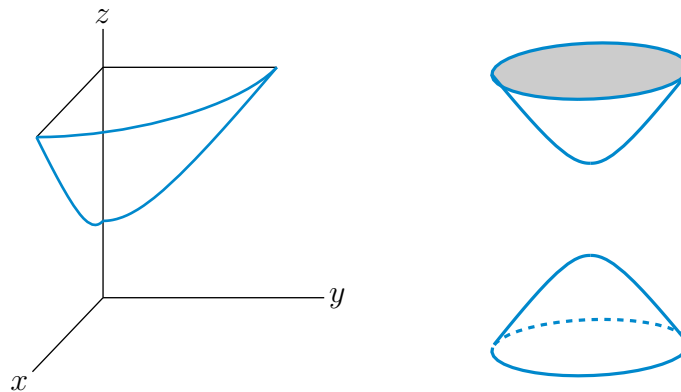

S-6: For each fixed z , $4x^2 + y^2 = 1 + z^2$ is an ellipse. So the surface consists of a stack of ellipses one on top of the other. The semi axes are $\frac{1}{2}\sqrt{1 + z^2}$ and $\sqrt{1 + z^2}$. These are smallest when $z = 0$ (i.e. for the ellipse in the xy -plane) and increase as $|z|$ increases. The intersection of the surface with the xz -plane (i.e. with the plane $y = 0$) is the hyperbola $4x^2 - z^2 = 1$ and the intersection with the yz -plane (i.e. with the plane $x = 0$) is the hyperbola $y^2 - z^2 = 1$. Here are two sketches of the surface. The sketch on the left only shows the part of the surface in the first octant (with axes).

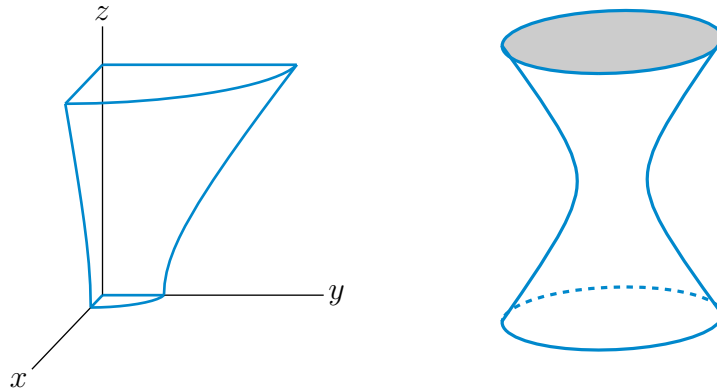

S-7: (a) The graph is $z = \sin x$ with (x, y) running over $0 \leq x \leq 2\pi$, $0 \leq y \leq 1$. For each fixed y_0 between 0 and 1, the intersection of this graph with the vertical plane $y = y_0$ is the same sin graph $z = \sin x$ with x running from 0 to 2π . So the whole graph is just a bunch of 2-d sin graphs stacked side-by-side. This gives the graph on the left below.

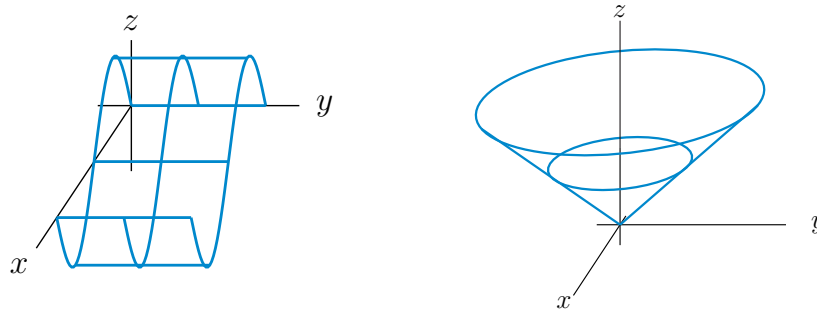

(b) The graph is $z = \sqrt{x^2 + y^2}$. For each fixed $z_0 \geq 0$, the intersection of this graph with the horizontal plane $z = z_0$ is the circle $\sqrt{x^2 + y^2} = z_0$. This circle is centred on the z -axis and has radius z_0 . So the graph is the upper half of a cone. It is the sketch on the right above.

(c) The graph is $z = |x| + |y|$. For each fixed $z_0 \geq 0$, the intersection of this graph with the horizontal plane $z = z_0$ is the square $|x| + |y| = z_0$. The side of the square with $x, y \geq 0$ is the straight line $x + y = z_0$. The side of the square with $x \geq 0$ and $y \leq 0$ is the straight line $x - y = z_0$ and so on. The four corners of the square are $(\pm z_0, 0, z_0)$ and $(0, \pm z_0, z_0)$. So the graph is a stack of squares. It is an upside down four-sided pyramid. The part of the pyramid in the first octant (that is, $x, y, z \geq 0$) is the sketch below.

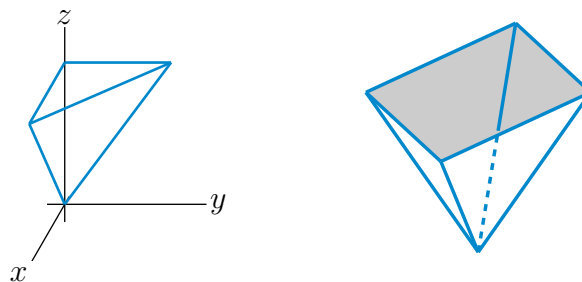

S-8: (a) For each fixed z_0 , the $z = z_0$ cross-section (parallel to the xy -plane) of this surface is an ellipse centered on the origin with one semiaxis of length 2 along the x -axis and one semiaxis of length 4 along the y -axis. So this is an elliptic cylinder parallel to the z -axis. Here is a sketch of the

part of the surface above the xy -plane.

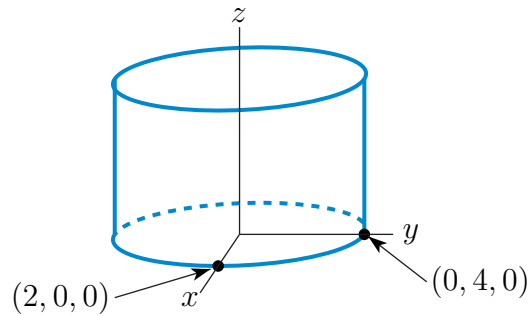

(b) This is a plane through $(4, 0, 0)$, $(0, 4, 0)$ and $(0, 0, 2)$. Here is a sketch of the part of the plane in the first octant.

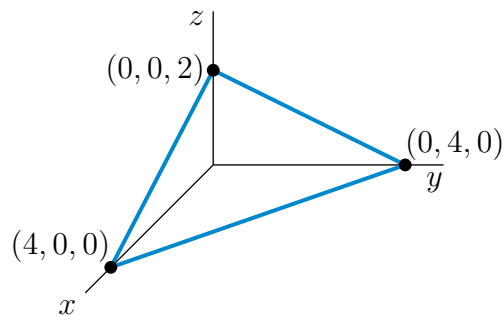

(c) For each fixed x_0 , the $x = x_0$ cross-section parallel to the yz -plane is an ellipse with semiaxes $3\sqrt{1 + \frac{x_0^2}{16}}$ parallel to the y -axis and $2\sqrt{1 + \frac{x_0^2}{16}}$ parallel to the z -axis. As you move out along the x -axis, away from $x = 0$, the ellipses grow at a rate proportional to $\sqrt{1 + \frac{x^2}{16}}$, which for large x is approximately $\frac{|x|}{4}$. This is called a hyperboloid of one sheet. Its

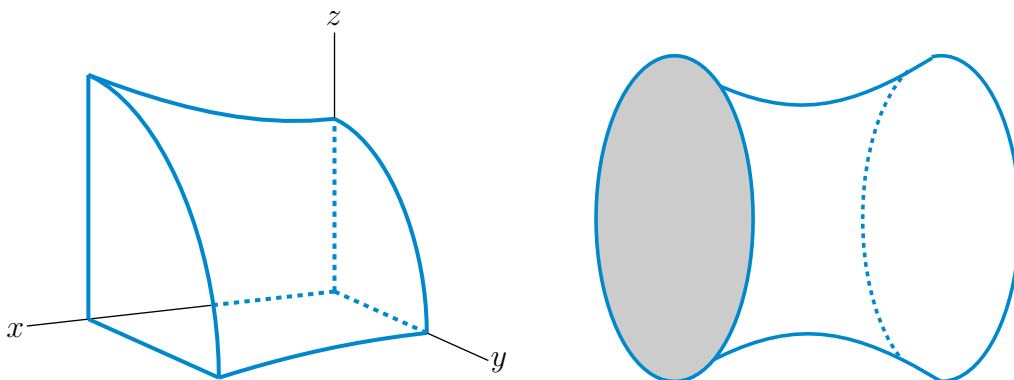

(d) For each fixed y_0 , the $y = y_0$ cross-section (parallel to the xz -plane) is a circle of radius $|y|$ centred on the xz -plane. When $y_0 = 0$ the radius is 0. As you move further from the xz -plane, in either direction, i.e. as $|y_0|$ increases, the radius grows linearly. The full surface consists of a bunch of these circles stacked sideways. This is a circular cone centred on the y -axis.

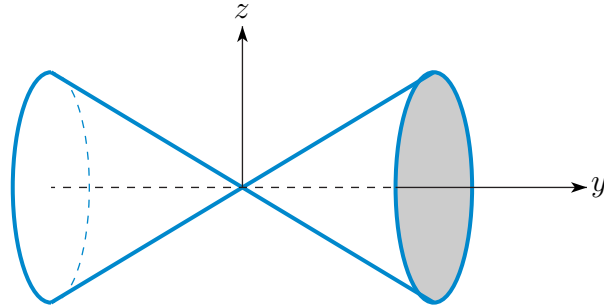

(e) This is an ellipsoid centered on the origin with semiaxes 3, $\sqrt{12} = 2\sqrt{3}$ and 3 along the x , y and z -axes, respectively.

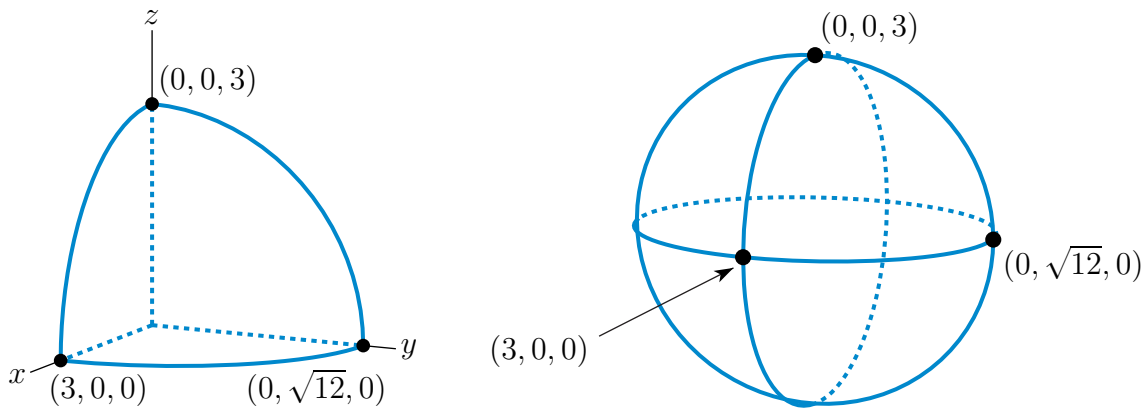

(f) Completing three squares, we have that $x^2 + y^2 + z^2 + 4x - by + 9z - b = 0$ if and only if $(x+2)^2 + (y-\frac{b}{2})^2 + (z+\frac{9}{2})^2 = b+4 + \frac{b^2}{4} + \frac{81}{4}$. This is a sphere of radius $r_b = \frac{1}{2}\sqrt{b^2 + 4b + 97}$ centered on $\frac{1}{2}(-4, b, -9)$.

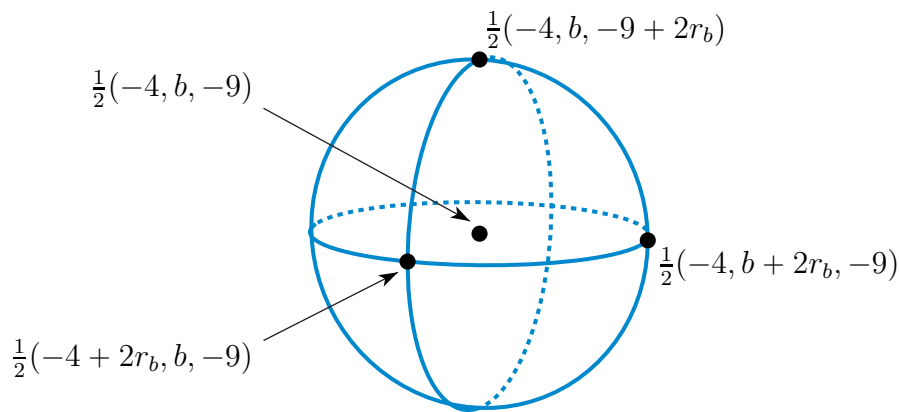

(g) There are no points on the surface with $x < 0$. For each fixed $x_0 > 0$ the cross-section $x = x_0$ parallel to the yz -plane is an ellipse centred on the x -axis with semiaxes $\sqrt{x_0}$ in the y -axis direction and $\frac{3}{2}\sqrt{x_0}$ in the z -axis direction. As you increase x_0 , i.e. move out along the x -axis, the ellipses grow at a rate proportional to $\sqrt{x_0}$. This is an elliptic paraboloid with axis the x -axis.

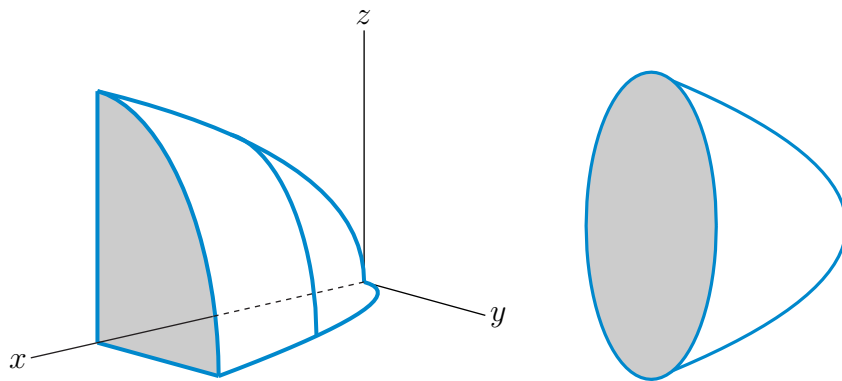

(h) This is called a parabolic cylinder. For any fixed y_0 , the $y = y_0$ cross-section (parallel to the xz -plane) is the upward opening parabola $z = x^2$ which has vertex on the y -axis.

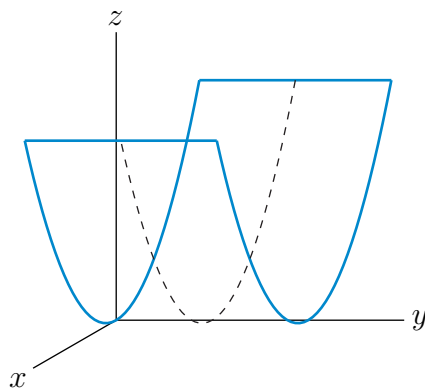

S-9: The level curves of $z = 0$ correspond to all points (x, y) such that $0 = \sin(x + y)$. The angles that make $\sin \theta$ equal to 0 are $\theta = \pi n$ for integer values of n . So, the level curves are lines of the form

$$x + y = \pi n$$

where n is any integer.

So, our level curve has the lines $y = -x$, $y = \pi - x$, $y = 2\pi - x$, etc.

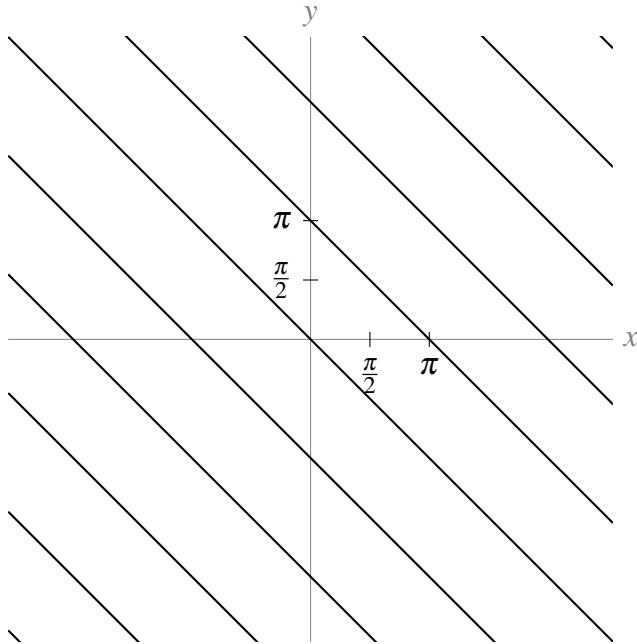

The level curves of $z = 1$ correspond to all points (x, y) such that $1 = \sin(x + y)$. The angles that make $\sin \theta$ equal to 1 are $\theta = \frac{\pi}{2} + 2\pi n$ for integer values of n . So, the level curves are lines of the form

$$x + y = \frac{\pi}{2} + 2\pi n$$

where n is any integer.

So, our level curve has the lines $y = \frac{\pi}{2} - x$, $y = \frac{\pi}{2} + 2\pi - x$, $y = \frac{\pi}{2} + 4\pi - x$, etc.

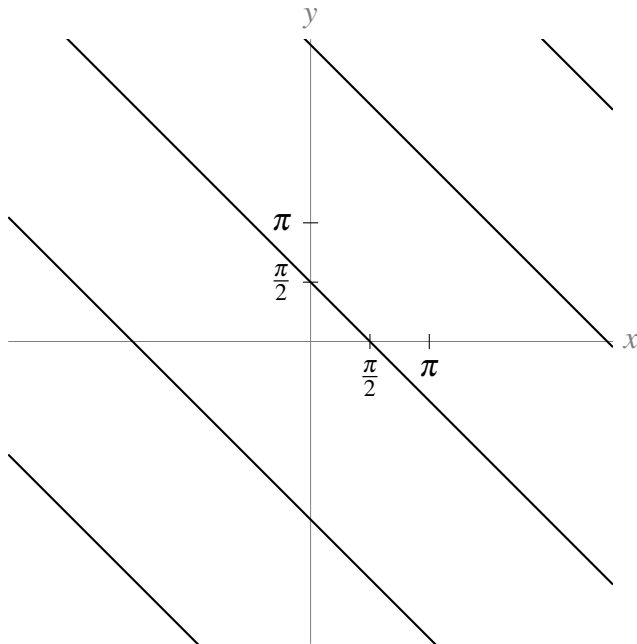

The equation $2 = \sin(x + y)$ has no solutions, since no angle has sine greater than 1. So the level curve at $z = 2$ has no points:

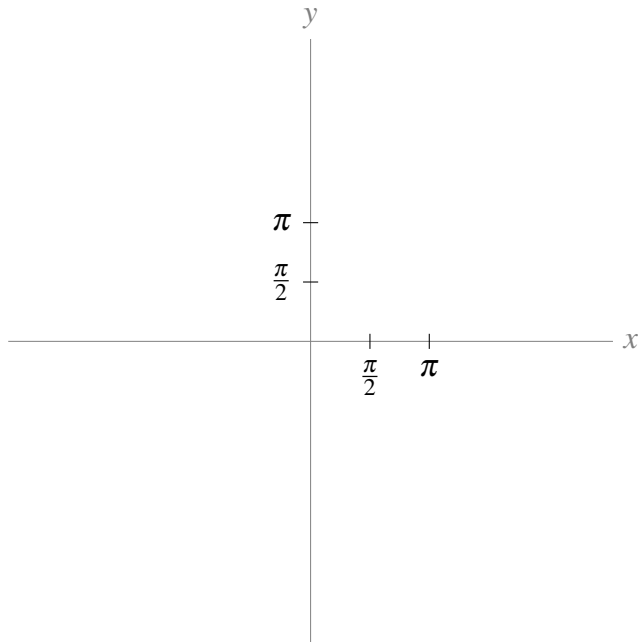

S-10: Since the level curves are circles centred at the origin (in the xy -plane), when z is a constant, the equation will have the form $x^2 + y^2 = c$ for some constant. That is, our equation looks like

$$x^2 + y^2 = g(z),$$

where $g(z)$ is a function depending only on z .

Because our cross-sections are so nicely symmetric, we know the intersection of the figure with the left side of the yz -plane as well: $z = 3(-y - 1) = -3(y + 1)$ (when $z \geq 0$) and $z = -3(-y - 1) = 3(y + 1)$ (when $z < 0$). Below is the intersection of our surface with the yz plane.

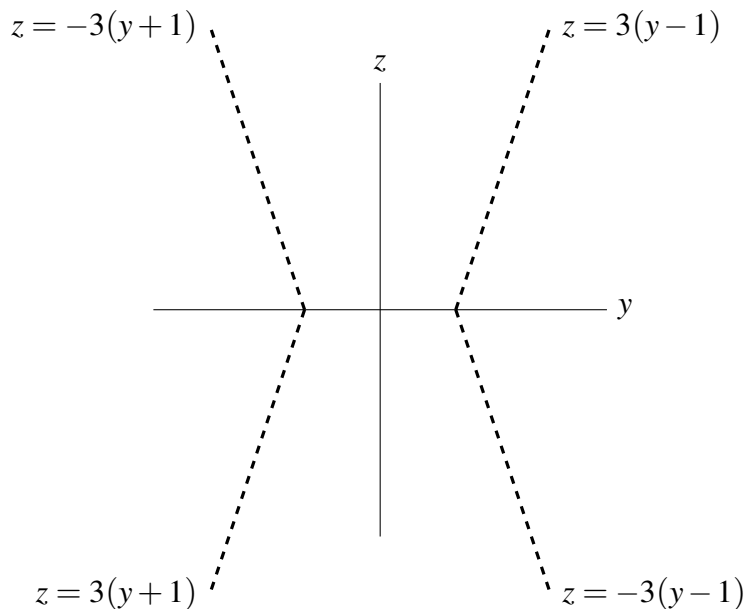

Setting $x = 0$, our equation becomes $y^2 = g(z)$. Looking at the right side of the yz plane, this should

lead to: $\left\{ \begin{array}{ll} z = 3(y-1) & \text{if } z \geq 0, y \geq 1 \\ z = -3(y-1) & \text{if } z < 0, y \geq 1 \end{array} \right\}$. That is:

$$\begin{aligned} |z| &= 3(y-1) \\ \frac{|z|}{3} + 1 &= y \\ \left(\frac{|z|}{3} + 1\right)^2 &= y^2 \end{aligned} \tag{*}$$

A quick check: when we squared both sides of the equation in (*), we added another solution, $\frac{|z|}{3} + 1 = -y$. Let's make sure we haven't diverged from our diagram.

$$\begin{aligned} & \left(\frac{|z|}{3} + 1\right)^2 = y^2 \\ \Leftrightarrow & \underbrace{\frac{|z|}{3} + 1}_{\text{positive}} = \pm y \\ \Leftrightarrow & \begin{cases} \frac{|z|}{3} + 1 = y & y > 0 \\ \frac{|z|}{3} + 1 = -y & y < 0 \end{cases} \\ \Leftrightarrow & \begin{cases} \frac{|z|}{3} + 1 = y & y \geq 1 \\ \frac{|z|}{3} + 1 = -y & y \leq -1 \end{cases} \\ \Leftrightarrow & \begin{cases} |z| = 3(y-1) & y \geq 1 \\ |z| = -3(y+1) & y \leq -1 \end{cases} \\ \Leftrightarrow & \begin{cases} z = \pm \underbrace{3(y-1)}_{\text{positive}} & y \geq 1 \\ z = \pm \underbrace{3(y+1)}_{\text{negative}} & y \leq -1 \end{cases} \\ \Leftrightarrow & \begin{cases} z = 3(y-1) & y \geq 1, z \geq 0 \\ z = -3(y-1) & y \geq 1, z \leq 0 \\ z = -3(y+1) & y \leq -1, z \geq 0 \\ z = 3(y+1) & y \leq -1, z \leq 0 \end{cases} \end{aligned}$$

This matches our diagram exactly. So, all together, the equation of the surface is

$$x^2 + y^2 = \left(\frac{|z|}{3} + 1\right)^2$$

Solutions to Exercises 15.1 — Jump to [TABLE OF CONTENTS](#)

S-1:

If $f_y(0,0) < 0$, then $f(0,y)$ decreases as y increases from 0. Thus moving in the positive y direction takes you downhill. This means you aren't at the lowest point in a valley, since you can still move downhill. On the other hand, as $f_y(0,0) < 0$, $f(0,y)$ also decreases as y increases towards 0 from slightly negative values. Thus if you move in the *negative* y -direction from $y = 0$, your height z will *increase*. So you are not at a locally highest point—you're not at a summit.

S-2: The definition of the derivative involves a limit as h goes to 0; we can approximate that limit by choosing a value of h that's close to 0; in our case, 0.1 or -0.1 are the best we can do, using the information on the table.

$$f_x(x,y) = \lim_{h \rightarrow 0} \frac{f(x+h,y) - f(x,y)}{h} \approx \frac{f(x+0.1,y) - f(x,y)}{0.1}$$

$$f_y(x,y) = \lim_{h \rightarrow 0} \frac{f(x,y+h) - f(x,y)}{h} \approx \frac{f(x,y+0.1) - f(x,y)}{0.1}$$

(a) To find $f_y(1.5,2.4)$, we keep x fixed at $x = 1.5$, and vary y . We don't know what happens at $y = 2.5$, but we do know what happens at $y = 2.3$:

$$f_y(1.5,2.4) \approx \frac{f(1.5,2.3) - f(1.5,2.4)}{2.3 - 2.4} = \frac{11.2 - 11.0}{-0.1} = -2$$

(b) To find $f_x(1.7,1.7)$, we keep y fixed at $y = 1.7$, and vary x . We can choose to use either $x = 1.6$ or $x = 1.8$.

$$f_x(1.7,1.7) \approx \frac{f(1.8,1.7) - f(1.7,1.7)}{1.8 - 1.7} = \frac{16.1 - 15.0}{0.1} = 11$$

$$f_x(1.7,1.7) \approx \frac{f(1.6,1.7) - f(1.7,1.7)}{1.6 - 1.7} = \frac{13.9 - 15.0}{-0.1} = 11$$

(c) To find $f_y(1.7,1.7)$, we keep x fixed at $x = 1.7$, and vary y . We can choose to use either $y = 1.6$ or $y = 1.8$.

$$f_y(1.7,1.7) \approx \frac{f(1.7,1.8) - f(1.7,1.7)}{1.8 - 1.7} = \frac{14.7 - 15.0}{0.1} = -3$$

$$f_y(1.7,1.7) \approx \frac{f(1.7,1.6) - f(1.7,1.7)}{1.6 - 1.7} = \frac{15.3 - 15.0}{-0.1} = -3$$

(d) To find $f_x(1.1,2)$, we keep y fixed at $y = 2$, and vary x . We can choose to use either $x = 1.0$ or $x = 1.2$.

$$f_x(1.1,2) \approx \frac{f(1.2,2) - f(1.1,2)}{1.2 - 1.1} = \frac{9.1 - 8.2}{0.1} = 9$$

$$f_x(1.1,2) \approx \frac{f(1.0,2) - f(1.1,2)}{1.0 - 1.1} = \frac{7.3 - 8.2}{-0.1} = 9$$

S-3: (a)

$$\begin{aligned}f_x(x, y, z) &= 3x^2y^4z^5 & f_x(0, -1, -1) &= 0 \\f_y(x, y, z) &= 4x^3y^3z^5 & f_y(0, -1, -1) &= 0 \\f_z(x, y, z) &= 5x^3y^4z^4 & f_z(0, -1, -1) &= 0\end{aligned}$$

(b)

$$\begin{aligned}w_x(x, y, z) &= \frac{yz e^{xyz}}{1 + e^{xyz}} & w_x(2, 0, -1) &= 0 \\w_y(x, y, z) &= \frac{xz e^{xyz}}{1 + e^{xyz}} & w_y(2, 0, -1) &= -1 \\w_z(x, y, z) &= \frac{xy e^{xyz}}{1 + e^{xyz}} & w_z(2, 0, -1) &= 0\end{aligned}$$

(c)

$$\begin{aligned}f_x(x, y) &= -\frac{x}{(x^2 + y^2)^{3/2}} & f_x(-3, 4) &= \frac{3}{125} \\f_y(x, y) &= -\frac{y}{(x^2 + y^2)^{3/2}} & f_y(-3, 4) &= -\frac{4}{125}\end{aligned}$$

S-4: By the quotient rule

$$\begin{aligned}\frac{\partial z}{\partial x}(x, y) &= \frac{(1)(x-y) - (x+y)(1)}{(x-y)^2} = \frac{-2y}{(x-y)^2} \\ \frac{\partial z}{\partial y}(x, y) &= \frac{(1)(x-y) - (x+y)(-1)}{(x-y)^2} = \frac{2x}{(x-y)^2}\end{aligned}$$

Hence

$$x \frac{\partial z}{\partial x}(x, y) + y \frac{\partial z}{\partial y}(x, y) = \frac{-2xy + 2yx}{(x-y)^2} = 0$$

S-5: (a) We are told that $z(x, y)$ obeys

$$\begin{aligned}z(x, y)y - y + x &= \log(xy z(x, y)) \\ &= \log x + \log y + \log(z(x, y))\end{aligned} \tag{*}$$

for all (x, y) (near $(-1, -2)$). Recall the following derivatives:

- The partial derivative of z with respect to x is $\frac{\partial z}{\partial x}$
- The partial derivative of y with respect to x is 0 (since we treat y as a constant)
- The partial derivative of x with respect to x is 1

Differentiating (*) with respect to x gives

$$y \frac{\partial z}{\partial x}(x, y) + 1 = \frac{1}{x} + \frac{\frac{\partial z}{\partial x}(x, y)}{z(x, y)} \implies \frac{\partial z}{\partial x}(x, y) = \frac{\frac{1}{x} - 1}{y - \frac{1}{z(x, y)}}$$

or, dropping the arguments (x, y) and multiplying both the numerator and denominator by xz ,

$$\frac{\partial z}{\partial x} = \frac{z - xz}{xyz - x} = \frac{z(1 - x)}{x(yz - 1)}$$

Differentiating (*) with respect to y gives

$$z(x, y) + y \frac{\partial z}{\partial y}(x, y) - 1 = \frac{1}{y} + \frac{\frac{\partial z}{\partial y}(x, y)}{z(x, y)} \implies \frac{\partial z}{\partial y}(x, y) = \frac{\frac{1}{y} + 1 - z(x, y)}{y - \frac{1}{z(x, y)}}$$

or, dropping the arguments (x, y) and multiplying both the numerator and denominator by yz ,

$$\frac{\partial z}{\partial y} = \frac{z + yz - yz^2}{y^2z - y} = \frac{z(1 + y - yz)}{y(yz - 1)}$$

(b) When $(x, y, z) = (-1, -2, 1/2)$,

$$\begin{aligned} \frac{\partial z}{\partial x}(-1, -2) &= \left. \frac{\frac{1}{x} - 1}{y - \frac{1}{z}} \right|_{(x, y, z) = (-1, -2, 1/2)} = \frac{\frac{1}{-1} - 1}{-2 - 2} = \frac{1}{2} \\ \frac{\partial z}{\partial y}(-1, -2) &= \left. \frac{\frac{1}{y} + 1 - z}{y - \frac{1}{z}} \right|_{(x, y, z) = (-1, -2, 1/2)} = \frac{\frac{1}{-2} + 1 - \frac{1}{2}}{-2 - 2} = 0 \end{aligned}$$

S-6: We are told that the four variables T, U, V, W obey the the single equation $(TU - V)^2 \log(W - UV) = \log 2$. So they are not all independent variables. Roughly speaking, we can treat any three of them as independent variables and solve the given equation for the fourth as a function of the three chosen independent variables.

We are first asked to find $\frac{\partial U}{\partial T}$. This implicitly tells to treat T, V and W as independent variables and to view U as a function $U(T, V, W)$ that obeys

$$(TU(T, V, W) - V)^2 \log(W - U(T, V, W)V) = \log 2 \quad (\text{E1})$$

for all (T, U, V, W) sufficiently near $(1, 1, 2, 4)$. Differentiating (E1) with respect to T gives

$$\begin{aligned} 2(TU(T, V, W) - V) \left[U(T, V, W) + T \frac{\partial U}{\partial T}(T, V, W) \right] \log(W - U(T, V, W)V) \\ - (TU(T, V, W) - V)^2 \frac{1}{W - U(T, V, W)V} \frac{\partial U}{\partial T}(T, V, W)V = 0 \end{aligned}$$

In particular, for $(T, U, V, W) = (1, 1, 2, 4)$,

$$2((1)(1) - 2) \left[1 + (1) \frac{\partial U}{\partial T}(1, 2, 4) \right] \log(4 - (1)(2)) - ((1)(1) - 2)^2 \frac{1}{4 - (1)(2)} \frac{\partial U}{\partial T}(1, 2, 4) (2) = 0$$

This simplifies to

$$-2 \left[1 + \frac{\partial U}{\partial T}(1, 2, 4) \right] \log(2) - \frac{\partial U}{\partial T}(1, 2, 4) = 0 \implies \frac{\partial U}{\partial T}(1, 2, 4) = -\frac{2 \log(2)}{1 + 2 \log(2)}$$

We are then asked to find $\frac{\partial T}{\partial V}$. This implicitly tells to treat U, V and W as independent variables and to view T as a function $T(U, V, W)$ that obeys

$$(T(U, V, W)U - V)^2 \log(W - UV) = \log 2 \quad (\text{E2})$$

for all (T, U, V, W) sufficiently near $(1, 1, 2, 4)$. Differentiating (E2) with respect to V gives

$$2(T(U, V, W)U - V) \left[\frac{\partial T}{\partial V}(U, V, W)U - 1 \right] \log(W - UV) - (T(U, V, W)U - V)^2 \frac{U}{W - UV} = 0$$

In particular, for $(T, U, V, W) = (1, 1, 2, 4)$,

$$2((1)(1) - 2) \left[(1) \frac{\partial T}{\partial V}(1, 2, 4) - 1 \right] \log(4 - (1)(2)) - ((1)(1) - 2)^2 \frac{1}{4 - (1)(2)} = 0$$

This simplifies to

$$-2 \left[\frac{\partial T}{\partial V}(1, 2, 4) - 1 \right] \log(2) - \frac{1}{2} = 0 \implies \frac{\partial T}{\partial V}(1, 2, 4) = 1 - \frac{1}{4 \log(2)}$$

S-7: The function

$$\begin{aligned} u(\rho, r, \theta) &= [\rho r \cos \theta]^2 + [\rho r \sin \theta] \rho r \\ &= \rho^2 r^2 \cos^2 \theta + \rho^2 r^2 \sin \theta \end{aligned}$$

So

$$\frac{\partial u}{\partial r}(\rho, r, \theta) = 2\rho^2 r \cos^2 \theta + 2\rho^2 r \sin \theta$$

and

$$\frac{\partial u}{\partial r}(2, 3, \pi/2) = 2(2^2)(3)(0)^2 + 2(2^2)(3)(1) = 24$$

S-8: By definition

$$f_x(x_0, y_0) = \lim_{\Delta x \rightarrow 0} \frac{f(x_0 + \Delta x, y_0) - f(x_0, y_0)}{\Delta x} \quad f_y(x_0, y_0) = \lim_{\Delta y \rightarrow 0} \frac{f(x_0, y_0 + \Delta y) - f(x_0, y_0)}{\Delta y}$$

Setting $x_0 = y_0 = 0$,

$$\begin{aligned} f_x(0, 0) &= \lim_{\Delta x \rightarrow 0} \frac{f(\Delta x, 0) - f(0, 0)}{\Delta x} = \lim_{\Delta x \rightarrow 0} \frac{f(\Delta x, 0)}{\Delta x} = \lim_{\Delta x \rightarrow 0} \frac{((\Delta x)^2 - 2 \times 0^2) / (\Delta x - 0)}{\Delta x} \\ &= \lim_{\Delta x \rightarrow 0} 1 = 1 \end{aligned}$$

$$\begin{aligned} f_y(0, 0) &= \lim_{\Delta y \rightarrow 0} \frac{f(0, \Delta y) - f(0, 0)}{\Delta y} = \lim_{\Delta y \rightarrow 0} \frac{f(0, \Delta y)}{\Delta y} = \lim_{\Delta y \rightarrow 0} \frac{(0^2 - 2(\Delta y)^2) / (0 - \Delta y)}{\Delta y} \\ &= \lim_{\Delta y \rightarrow 0} 2 = 2 \end{aligned}$$

S-9: As $z(x, y) = f(x^2 + y^2)$

$$\frac{\partial z}{\partial x}(x, y) = 2xf'(x^2 + y^2)$$

$$\frac{\partial z}{\partial y}(x, y) = 2yf'(x^2 + y^2)$$

by the (ordinary single variable) chain rule. So

$$y \frac{\partial z}{\partial x} - x \frac{\partial z}{\partial y} = y(2x)f'(x^2 + y^2) - x(2y)f'(x^2 + y^2) = 0$$

and the differential equation is always satisfied, assuming that f is differentiable, so that the chain rule applies.

S-10: By definition

$$\begin{aligned} \frac{\partial f}{\partial x}(0, 0) &= \lim_{\Delta x \rightarrow 0} \frac{f(\Delta x, 0) - f(0, 0)}{\Delta x} \\ &= \lim_{\Delta x \rightarrow 0} \frac{\frac{(\Delta x + 2 \times 0)^2}{\Delta x + 0} - 0}{\Delta x} \\ &= \lim_{\Delta x \rightarrow 0} \frac{\Delta x}{\Delta x} \\ &= 1 \end{aligned}$$

and

$$\begin{aligned} \frac{\partial f}{\partial y}(0, 0) &= \lim_{\Delta y \rightarrow 0} \frac{f(0, \Delta y) - f(0, 0)}{\Delta y} \\ &= \lim_{\Delta y \rightarrow 0} \frac{\frac{(0 + 2\Delta y)^2}{0 + \Delta y} - 0}{\Delta y} \\ &= \lim_{\Delta y \rightarrow 0} \frac{4\Delta y}{\Delta y} \\ &= 4 \end{aligned}$$

(b) $f(x,y)$ is *not continuous* at $(0,0)$, even though both partial derivatives exist there. To see this, make a change of coordinates from (x,y) to (X,y) with $X = x + y$ (the denominator). Of course, $(x,y) \rightarrow (0,0)$ if and only if $(X,y) \rightarrow (0,0)$. Now watch what happens when $(X,y) \rightarrow (0,0)$ with X a lot smaller than y . For example, $X = ay^2$. Then

$$\frac{(x+2y)^2}{x+y} = \frac{(X+y)^2}{X} = \frac{(ay^2+y)^2}{ay^2} = \frac{(1+ay)^2}{a} \rightarrow \frac{1}{a}$$

This depends on a . So approaching $(0,0)$ along different paths gives different limits. (You can see the same effect without changing coordinates by sending $(x,y) \rightarrow (0,0)$ with $x = -y + ay^2$.) Even more dramatically, watch what happens when $(X,y) \rightarrow (0,0)$ with $X = y^3$. Then

$$\frac{(x+2y)^2}{x+y} = \frac{(X+y)^2}{X} = \frac{(y^3+y)^2}{y^3} = \frac{(1+y^2)^2}{y} \rightarrow \pm\infty$$

S-11: Solution 1

Let's start by finding an equation for this surface. Every level curve is a horizontal circle of radius one, so the equation should be of the form

$$(x - f_1)^2 + (y - f_2)^2 = 1$$

where f_1 and f_2 are functions depending only on z . Since the centre of the circle at height z is at position $x = 0, y = z$, we see that the equation of our surface is

$$x^2 + (y - z)^2 = 1$$

The height of the surface at the point (x,y) is the $z(x,y)$ found by solving that equation. That is,

$$x^2 + (y - z(x,y))^2 = 1 \tag{*}$$

We differentiate this equation implicitly to find $z_x(x,y)$ and $z_y(x,y)$ at the desired point $(x,y) = (0, -1)$. First, differentiating (*) with respect to y gives

$$\begin{aligned} 0 + 2(y - z(x,y))(1 - z_y(x,y)) &= 0 \\ 2(-1 - 0)(1 - z_y(0, -1)) &= 0 \qquad \text{at } (0, -1, 0) \end{aligned}$$

so that the slope looking in the positive y direction is $z_y(0, -1) = 1$. Similarly, differentiating (*) with respect to x gives

$$\begin{aligned} 2x + 2(y - z(x,y)) \cdot (0 - z_x(x,y)) &= 0 \\ 2x &= 2(y - z(x,y)) \cdot z_x(x,y) \\ z_x(x,y) &= \frac{x}{y - z(x,y)} \\ z_x(0, -1) &= 0 \qquad \text{at } (0, -1, 0) \end{aligned}$$

The slope looking in the positive x direction is $z_x(0, -1) = 0$.

Solution 2

Standing at $(0, -1, 0)$ and looking in the positive y direction, the surface follows the straight line that

- passes through the point $(0, -1, 0)$, and
- is parallel to the central line $z = y, x = 0$ of the cylinder.

Shifting the central line one unit in the y -direction, we get the line $z = y + 1, x = 0$. (As a check, notice that $(0, -1, 0)$ is indeed on $z = y + 1, x = 0$.) The slope of this line is 1.

Standing at $(0, -1, 0)$ and looking in the positive x direction, the surface follows the circle $x^2 + y^2 = 1, z = 0$, which is the intersection of the cylinder with the xy -plane. As we move along that circle our z coordinate stays fixed at 0. So the slope in that direction is 0.

S-12: (a) By definition

$$\begin{aligned}\frac{\partial f}{\partial x}(0,0) &= \lim_{\Delta x \rightarrow 0} \frac{f(\Delta x, 0) - f(0,0)}{\Delta x} \\ &= \lim_{\Delta x \rightarrow 0} \frac{\frac{(\Delta x^2)(0)}{\Delta x^2 + 0^2} - 0}{\Delta x} \\ &= 0\end{aligned}$$

(b) By definition

$$\begin{aligned}\frac{\partial f}{\partial y}(0,0) &= \lim_{\Delta y \rightarrow 0} \frac{f(0, \Delta y) - f(0,0)}{\Delta y} \\ &= \lim_{\Delta y \rightarrow 0} \frac{\frac{(0^2)(\Delta y)}{0^2 + \Delta y^2} - 0}{\Delta y} \\ &= 0\end{aligned}$$

(c) By definition

$$\begin{aligned}\left. \frac{d}{dt} f(t,t) \right|_{t=0} &= \lim_{t \rightarrow 0} \frac{f(t,t) - f(0,0)}{t} \\ &= \lim_{t \rightarrow 0} \frac{\frac{(t^2)(t)}{t^2 + t^2} - 0}{t} \\ &= \lim_{t \rightarrow 0} \frac{t/2}{t} \\ &= \frac{1}{2}\end{aligned}$$

Solutions to Exercises 15.2 — Jump to [TABLE OF CONTENTS](#)

S-1: From the example that “ f_x ” is the partial derivative of f with respect to x , we infer that the notation for “take the partial derivative with respect to (variable)” is “write (variable) on the bottom right.” Continuing this practice, to take the partial derivative with respect to y of f_x , we should write the y on the bottom right – that is, to the right of the x :

$$(f_x)_y$$

Since x is to the left of y , we write the above as f_{xy} , not f_{yx} .

S-2: From the example that “ $\frac{\partial}{\partial x}f$ ” is the partial derivative of f with respect to x , we infer that the notation for “take the partial derivative of a function with respect to (variable)” is “put the partial derivative operator $\frac{\partial}{\partial(\text{variable})}$ to the left of the function.” Continuing this practice, to take the partial derivative with respect to y of $\frac{\partial f}{\partial x}$, we should write the operator $\frac{\partial}{\partial y}$ on the left.

$$\frac{\partial}{\partial y} \left[\frac{\partial}{\partial x} f \right]$$

In the above expression, ∂y is to the left of the ∂x . So we write $\frac{\partial^2 f}{\partial y \partial x}$ rather than $\frac{\partial^2 f}{\partial x \partial y}$.

S-3: As in Question 2, if we want to differentiate $\frac{\partial f}{\partial x}$ with respect to x , we write:

$$\frac{\partial}{\partial x} \left[\frac{\partial}{\partial x} f \right] \quad \text{or} \quad \frac{\partial}{\partial x} \left[\frac{\partial f}{\partial x} \right]$$

In both cases:

- f shows up only once, so we don't add an exponent to it.
- ∂ shows up twice in the numerator, so we write ∂^2 as shorthand for $\partial[\partial]$.
- ∂x shows up twice in the denominator, so we write ∂x^2 as shorthand for $\partial x[\partial x]$.

S-4:

$$\begin{aligned} f(x,y) &= \frac{\tan(xy)}{\ln x} \\ f_x &= \frac{\ln x (y \sec^2(xy)) - \tan(xy) \left(\frac{1}{x}\right)}{\ln^2 x} \\ &= \left(\frac{1}{\ln x}\right) y \sec^2(xy) - \left(\frac{1}{x \ln^2 x}\right) \tan(xy) \end{aligned}$$

We've separated out factors only depending on x , since these will act as constants when we differentiate with respect to y . Differentiating $\sec^2(xy)$ involves two layers of chain rule, so we'll figure that out on its own before we find f_{xy} .

$$\begin{aligned} \frac{\partial}{\partial y} \left[(\sec(xy))^2 \right] &= 2 \sec(xy) \cdot \frac{\partial}{\partial y} [\sec(xy)] \\ &= 2 \sec(xy) \cdot \sec(xy) \tan(xy) \cdot \frac{\partial}{\partial y} [xy] \\ &= 2 \sec(xy) \cdot \sec(xy) \tan(xy) \cdot x \\ &= 2x \sec^2(xy) \cdot \tan(xy) \end{aligned}$$

Now we differentiate f_x with respect to y .

$$\begin{aligned} f_{xy} &= \left(\frac{1}{\ln x}\right) (y \cdot 2x \sec^2(xy) \cdot \tan(xy) + \sec^2(xy)) - \left(\frac{1}{x \ln^2 x}\right) \sec^2(xy) \cdot x \\ &= \left(\frac{\sec^2(xy)}{\ln x}\right) (2xy \tan(xy) + 1) - \frac{\sec^2(xy)}{\ln^2 x} \end{aligned}$$

To find f_{yx} , we first differentiate f with respect to y .

$$f(x,y) = \left(\frac{1}{\ln x}\right) \tan(xy)$$

$$f_y = \frac{1}{\ln x} \cdot \sec^2(xy) \cdot x = \frac{x \sec^2(xy)}{\ln x}$$

We can differentiate this using the quotient rule. When we do, we'll need to find the derivative of the numerator. Since that takes several steps, we do it first.

$$\frac{\partial}{\partial x} [x \sec^2(xy)] = x \frac{\partial}{\partial x} [\sec^2(xy)] + \sec^2(xy)$$

We already found $\frac{\partial}{\partial x} [\sec^2(xy)] = 2x \sec^2(xy) \cdot \tan(xy)$. By an equivalent calculation, $\frac{\partial}{\partial y} [\sec^2(xy)] = 2y \sec^2(xy) \cdot \tan(xy)$

$$= x \cdot 2y \sec^2(xy) \cdot \tan(xy) + \sec^2(xy)$$

$$= \sec^2(xy) (2xy \tan(xy) + 1)$$

Now, let's differentiate f_y with respect to x .

$$f_{yx} = \frac{\ln x \cdot \sec^2(xy) (2xy \tan(xy) + 1) - x \sec^2(xy) \frac{1}{x}}{\ln^2 x}$$

To show that this is equal to f_{xy} , we rearrange.

$$= \frac{\ln x \cdot \sec^2(xy)}{\ln^2 x} (2xy \tan(xy) + 1) - \frac{x \sec^2(xy) \frac{1}{x}}{\ln^2 x}$$

$$= \left(\frac{\sec^2(xy)}{\ln x}\right) (2xy \tan(xy) + 1) - \frac{\sec^2(xy)}{\ln^2 x}$$

$$= f_{xy}$$

S-5: (a) We have

$$f_x(x,y) = 2xy^3 \quad f_{xx}(x,y) = 2y^3$$

$$f_{xy}(x,y) = 6xy^2 \quad f_{yxy}(x,y) = f_{xyy}(x,y) = 12xy$$

(b) We have

$$f_x(x,y) = y^2 e^{xy^2} \quad f_{xx}(x,y) = y^4 e^{xy^2} \quad f_{xxy}(x,y) = 4y^3 e^{xy^2} + 2xy^5 e^{xy^2}$$

$$f_{xy}(x,y) = 2ye^{xy^2} + 2xy^3 e^{xy^2} \quad f_{xyy}(x,y) = (2 + 4xy^2 + 6xy^2 + 4x^2y^4) e^{xy^2}$$

$$= (2 + 10xy^2 + 4x^2y^4) e^{xy^2}$$

(c) We have

$$\begin{aligned}\frac{\partial f}{\partial u}(u, v, w) &= -\frac{1}{(u + 2v + 3w)^2} \\ \frac{\partial^2 f}{\partial v \partial u}(u, v, w) &= \frac{4}{(u + 2v + 3w)^3} \\ \frac{\partial^3 f}{\partial w \partial v \partial u}(u, v, w) &= -\frac{36}{(u + 2v + 3w)^4}\end{aligned}$$

In particular,

$$\frac{\partial^3 f}{\partial w \partial v \partial u}(3, 2, 1) = -\frac{36}{(3 + 2 \times 2 + 3 \times 1)^4} = -\frac{36}{10^4} = -\frac{9}{2500}$$

S-6: Let $f(x, y) = \sqrt{x^2 + 5y^2}$. Then

$$\begin{aligned}f_x &= \frac{x}{\sqrt{x^2 + 5y^2}} & f_{xx} &= \frac{1}{\sqrt{x^2 + 5y^2}} - \frac{1}{2} \frac{(x)(2x)}{(x^2 + 5y^2)^{3/2}} & f_{xy} &= -\frac{1}{2} \frac{(x)(10y)}{(x^2 + 5y^2)^{3/2}} \\ f_y &= \frac{5y}{\sqrt{x^2 + 5y^2}} & f_{yy} &= \frac{5}{\sqrt{x^2 + 5y^2}} - \frac{1}{2} \frac{(5y)(10y)}{(x^2 + 5y^2)^{3/2}} & f_{yx} &= -\frac{1}{2} \frac{(5y)(2x)}{(x^2 + 5y^2)^{3/2}}\end{aligned}$$

Simplifying, and in particular using that $\frac{1}{\sqrt{x^2 + 5y^2}} = \frac{x^2 + 5y^2}{(x^2 + 5y^2)^{3/2}}$,

$$f_{xx} = \frac{5y^2}{(x^2 + 5y^2)^{3/2}} \quad f_{xy} = f_{yx} = -\frac{5xy}{(x^2 + 5y^2)^{3/2}} \quad f_{yy} = \frac{5x^2}{(x^2 + 5y^2)^{3/2}}$$

S-7: (a) As $f(x, y, z) = \arctan(e^{\sqrt{xy}})$ is independent of z , we have $f_z(x, y, z) = 0$ and hence

$$f_{xyz}(x, y, z) = f_{zxy}(x, y, z) = 0$$

(b) Write $u(x, y, z) = \arctan(e^{\sqrt{xy}})$, $v(x, y, z) = \arctan(e^{\sqrt{xz}})$ and $w(x, y, z) = \arctan(e^{\sqrt{yz}})$. Then

- As $u(x, y, z) = \arctan(e^{\sqrt{xy}})$ is independent of z , we have $u_z(x, y, z) = 0$ and hence $u_{xyz}(x, y, z) = u_{zxy}(x, y, z) = 0$
- As $v(x, y, z) = \arctan(e^{\sqrt{xz}})$ is independent of y , we have $v_y(x, y, z) = 0$ and hence $v_{xyz}(x, y, z) = v_{yxz}(x, y, z) = 0$
- As $w(x, y, z) = \arctan(e^{\sqrt{yz}})$ is independent of x , we have $w_x(x, y, z) = 0$ and hence $w_{xyz}(x, y, z) = 0$

As $f(x, y, z) = u(x, y, z) + v(x, y, z) + w(x, y, z)$, we have

$$f_{xyz}(x, y, z) = u_{xyz}(x, y, z) + v_{xyz}(x, y, z) + w_{xyz}(x, y, z) = 0$$

(c) In the course of evaluating $f_{xx}(x, 0, 0)$, both y and z are held fixed at 0. Thus, if we set $g(x) = f(x, 0, 0)$, then $f_{xx}(x, 0, 0) = g''(x)$. Now

$$g(x) = f(x, 0, 0) = \arctan(e^{\sqrt{xyz}}) \Big|_{y=z=0} = \arctan(1) = \frac{\pi}{4}$$

for all x . So $g'(x) = 0$ and $g''(x) = 0$ for all x . In particular,

$$f_{xx}(1, 0, 0) = g''(1) = 0$$

S-8: As

$$\begin{aligned} u_t(x, y, z, t) &= -\frac{3}{2} \frac{1}{t^{5/2}} e^{-(x^2+y^2+z^2)/(4\alpha t)} + \frac{1}{4\alpha t^{7/2}} (x^2 + y^2 + z^2) e^{-(x^2+y^2+z^2)/(4\alpha t)} \\ u_x(x, y, z, t) &= -\frac{x}{2\alpha t^{5/2}} e^{-(x^2+y^2+z^2)/(4\alpha t)} \\ u_{xx}(x, y, z, t) &= -\frac{1}{2\alpha t^{5/2}} e^{-(x^2+y^2+z^2)/(4\alpha t)} + \frac{x^2}{4\alpha^2 t^{7/2}} e^{-(x^2+y^2+z^2)/(4\alpha t)} \\ u_{yy}(x, y, z, t) &= -\frac{1}{2\alpha t^{5/2}} e^{-(x^2+y^2+z^2)/(4\alpha t)} + \frac{y^2}{4\alpha^2 t^{7/2}} e^{-(x^2+y^2+z^2)/(4\alpha t)} \\ u_{zz}(x, y, z, t) &= -\frac{1}{2\alpha t^{5/2}} e^{-(x^2+y^2+z^2)/(4\alpha t)} + \frac{z^2}{4\alpha^2 t^{7/2}} e^{-(x^2+y^2+z^2)/(4\alpha t)} \end{aligned}$$

we have

$$\alpha(u_{xx} + u_{yy} + u_{zz}) = -\frac{3}{2t^{5/2}} e^{-(x^2+y^2+z^2)/(4\alpha t)} + \frac{x^2 + y^2 + z^2}{4\alpha^2 t^{7/2}} e^{-(x^2+y^2+z^2)/(4\alpha t)} = u_t$$

S-9: The definition of the derivative involves a limit as h goes to 0; we can approximate that limit by choosing a value of h that's close to 0; in our case, 0.1 or -0.1 are the best we can do, using the information on the table.

$$\begin{aligned} f_x(x, y) &= \lim_{h \rightarrow 0} \frac{f(x+h, y) - f(x, y)}{h} \approx \frac{f(x+0.1, y) - f(x, y)}{0.1} \\ f_y(x, y) &= \lim_{h \rightarrow 0} \frac{f(x, y+h) - f(x, y)}{h} \approx \frac{f(x, y+0.1) - f(x, y)}{0.1} \end{aligned}$$

The same holds for the second derivative:

$$\begin{aligned} f_{xy}(x, y) &= (f_x(x, y))_y = \lim_{h \rightarrow 0} \frac{f_x(x, y+h) - f_x(x, y)}{h} \\ &\approx \frac{f_x(x, y+0.1) - f_x(x, y)}{0.1} \\ &= \frac{\left[\lim_{h \rightarrow 0} \frac{f(x+h, y+0.1) - f(x, y+0.1)}{h} \right] - \left[\lim_{h \rightarrow 0} \frac{f(x+h, y) - f(x, y)}{h} \right]}{0.1} \\ &\approx \frac{\left[\frac{f(x+0.1, y+0.1) - f(x, y+0.1)}{0.1} \right] - \left[\frac{f(x+0.1, y) - f(x, y)}{0.1} \right]}{0.1} \end{aligned}$$

These are the ideas we'll use in the approximations below.

The second partial derivative $f_{xy}(x, y)$ of f is the partial derivative of $f_x(x, y)$ with respect to y . That is:

$$f_{xy}(1.8, 2.0) = \lim_{h \rightarrow 0} \frac{f_x(1.8, 2.0 + h) - f_x(1.8, 2.0)}{h}$$

For our approximation, we can choose $h = 0.1$ or $h = -0.1$. There's no compelling reason to choose one over the other. Let's use $h = 0.1$.

$$\begin{aligned} &\approx \frac{f_x(1.8, 2.1) - f_x(1.8, 2.0)}{0.1} \\ &= \frac{\left[\lim_{h \rightarrow 0} \frac{f(1.8+h, 2.1) - f(1.8, 2.1)}{h} \right] - \left[\lim_{h \rightarrow 0} \frac{f(1.8+h, 2.0) - f(1.8, 2.0)}{h} \right]}{0.1} \end{aligned}$$

Once again, there's no compelling reason to choose $h = 0.1$ over $h = -0.1$. We could even choose different signs for the two limits. We'll just choose $h = 0.1$ again, because after all, we do have to choose something.

$$\begin{aligned} &\approx \frac{\left[\frac{f(1.9, 2.1) - f(1.8, 2.1)}{0.1} \right] - \left[\frac{f(1.9, 2.0) - f(1.8, 2.0)}{0.1} \right]}{0.1} \\ &= 100 \left[(f(1.9, 2.1) - f(1.8, 2.1)) - (f(1.9, 2.0) - f(1.8, 2.0)) \right] \\ &= 100 \left[(16.0 - 14.9) - (16.3 - 15.2) \right] \\ &= 0 \end{aligned}$$

Remark: different choices of h all end up with the same approximation.

Solutions to Exercises 16.1 — Jump to [TABLE OF CONTENTS](#)

S-1: a) (i) ∇f is zero or does not exist at critical points. The point T is a local maximum and the point U is a saddle point. The remaining points P, R, S , are not critical points.

(a) (ii) Only U is a saddle point.

(a) (iii) We have $f_y(x, y) > 0$ if f increases as you move vertically upward through (x, y) . Looking at the diagram, we see

$$f_y(P) < 0 \quad f_y(Q) < 0 \quad f_y(R) = 0 \quad f_y(S) > 0 \quad f_y(T) = 0 \quad f_y(U) = 0$$

So only S works.

(b) (i) The function $z = F(x, 2)$ is increasing at $x = 1$, because the $y = 2.0$ graph in the diagram has positive slope at $x = 1$. So $F_x(1, 2) > 0$.

(b) (ii) The function $z = F(x, 2)$ is also increasing (though slowly) at $x = 2$, because the $y = 2.0$ graph in the diagram has positive slope at $x = 2$. So $F_x(2, 2) > 0$. So F does *not* have a critical point at $(2, 2)$.

(b) (iii) From the diagram it looks like $F_x(1, 1.9) > F_x(1, 2.0) > F_x(1, 2.1)$. That is, it looks like the slope of the $y = 1.9$ graph at $x = 1$ is larger than the slope of the $y = 2.0$ graph at $x = 1$, which in turn is larger than the slope of the $y = 2.1$ graph at $x = 1$. So it looks like $F_x(1, y)$ decreases as y increases through $y = 2$, and consequently $F_{xy}(1, 2) < 0$.

S-2: (a)

- The level curve $z = 0$ is $y^2 - x^2 = 0$, which is the pair of 45° lines $y = \pm x$.
- When $C > 0$, the level curve $z = C^4$ is $(y^2 - x^2)^2 = C^4$, which is the pair of hyperbolae $y^2 - x^2 = C^2$, $y^2 - x^2 = -C^2$ or

$$y = \pm\sqrt{x^2 + C^2} \quad x = \pm\sqrt{y^2 + C^2}$$

The hyperbola $y^2 - x^2 = C^2$ crosses the y -axis (i.e. the line $x = 0$) at $(0, \pm C)$. The hyperbola $y^2 - x^2 = -C^2$ crosses the x -axis (i.e. the line $y = 0$) at $(\pm C, 0)$.

Here is a sketch showing the level curves $z = 0$, $z = 1$ (i.e. $C = 1$), and $z = 16$ (i.e. $C = 2$).

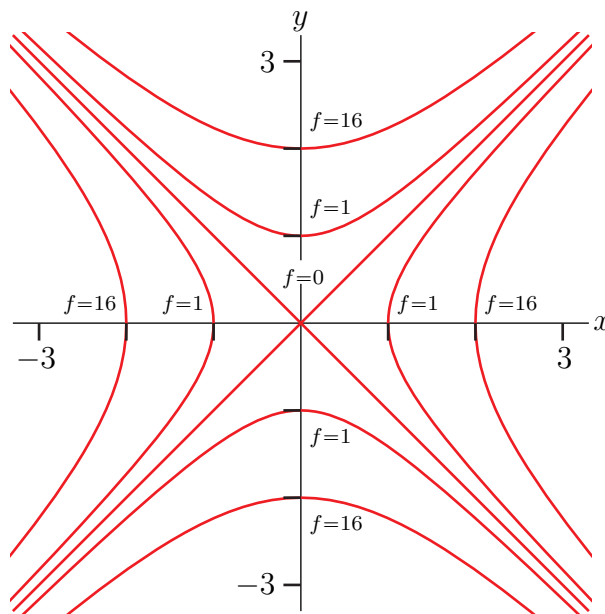

(b) As $f_x(x, y) = -4x(y^2 - x^2)$ and $f_y(x, y) = 4y(y^2 - x^2)$, we have $f_x(0, 0) = f_y(0, 0) = 0$ so that $(0, 0)$ is a critical point. Note that

- $f(0, 0) = 0$,
- $f(x, y) \geq 0$ for all x and y .

So $(0, 0)$ is a local (and also absolute) minimum.

(c) Note that

$$\begin{array}{ll} f_{xx}(x, y) = -4y^2 + 12x^2 & f_{xx}(x, y) = 0 \\ f_{yy}(x, y) = 12y^2 - 4x^2 & f_{yy}(x, y) = 0 \\ f_{xy}(x, y) = -8xy & f_{xy}(x, y) = 0 \end{array}$$

As $f_{xx}(0,0)f_{yy}(0,0) - f_{xy}(0,0)^2 = 0$, the Second Derivative Test (Theorem 16.1.14 in the text) tells us absolutely nothing.

S-3: Write $f(x,y) = x^2 + cxy + y^2$. Then

$$\begin{aligned} f_x(x,y) &= 2x + cy & f_x(0,0) &= 0 \\ f_y(x,y) &= cx + 2y & f_y(0,0) &= 0 \\ f_{xx}(x,y) &= 2 \\ f_{xy}(x,y) &= c \\ f_{yy}(x,y) &= 2 \end{aligned}$$

As $f_x(0,0) = f_y(0,0) = 0$, we have that $(0,0)$ is always a critical point for f . According to the Second Derivative Test, $(0,0)$ is also a saddle point for f if

$$f_{xx}(0,0)f_{yy}(0,0) - f_{xy}(0,0)^2 < 0 \iff 4 - c^2 < 0 \iff |c| > 2$$

As a remark, the Second Derivative Test provides no information when the expression $f_{xx}(0,0)f_{yy}(0,0) - f_{xy}(0,0)^2 = 0$, i.e. when $c = \pm 2$. But when $c = \pm 2$,

$$f(x,y) = x^2 \pm 2xy + y^2 = (x \pm y)^2$$

and f has a local minimum, not a saddle point, at $(0,0)$.

S-4: To find the critical points we will need the first order partial derivatives of f , and to apply the second derivative test of Theorem 16.1.14 in the text we will need all second order partial derivatives. So we need all partial derivatives of f up to order two. Here they are.

$$\begin{aligned} f &= x^3 - y^3 - 2xy + 6 \\ f_x &= 3x^2 - 2y & f_{xx} &= 6x & f_{xy} &= -2 \\ f_y &= -3y^2 - 2x & f_{yy} &= -6y & f_{yx} &= -2 \end{aligned}$$

The first order partial derivatives are defined everywhere so the critical points are the solutions of

$$f_x = 3x^2 - 2y = 0 \quad f_y = -3y^2 - 2x = 0$$

Substituting $y = \frac{3}{2}x^2$, from the first equation, into the second equation gives

$$\begin{aligned} -3 \left(\frac{3}{2}x^2 \right)^2 - 2x &= 0 \iff -2x \left(\frac{3^3}{2^3}x^3 + 1 \right) = 0 \\ &\iff x = 0, -\frac{2}{3} \end{aligned}$$

So there are two critical points: $(0,0)$, $(-\frac{2}{3}, \frac{2}{3})$.

The classification is

critical point	$f_{xx}f_{yy} - f_{xy}^2$	f_{xx}	type
$(0,0)$	$0 \times 0 - (-2)^2 < 0$		saddle point
$(-\frac{2}{3}, \frac{2}{3})$	$(-4) \times (-4) - (-2)^2 > 0$	-4	local max

S-5: To find the critical points we will need the first order partial derivatives of f , and to apply the second derivative test of Theorem 16.1.14 in the text we will need all second order partial derivatives. So we need all partial derivatives of f up to order two. Here they are.

$$\begin{aligned}
 f &= x^3 + x^2y + xy^2 - 9x \\
 f_x &= 3x^2 + 2xy + y^2 - 9 & f_{xx} &= 6x + 2y & f_{xy} &= 2x + 2y \\
 f_y &= x^2 + 2xy & f_{yy} &= 2x & f_{yx} &= 2x + 2y
 \end{aligned}$$

(Of course, f_{xy} and f_{yx} have to be the same. It is still useful to compute both, as a way to catch some mechanical errors.)

f_x and f_y are polynomials (in two variables) and so they are defined everywhere. Therefore the critical points are the solutions of

$$f_x = 3x^2 + 2xy + y^2 - 9 = 0 \tag{E1}$$

$$f_y = x(x + 2y) = 0 \tag{E2}$$

Equation (E2) is satisfied if at least one of $x = 0$, $x = -2y$.

- If $x = 0$, equation (E1) reduces to $y^2 - 9 = 0$, which is satisfied if $y = \pm 3$.
- If $x = -2y$, equation (E1) reduces to

$$0 = 3(-2y)^2 + 2(-2y)y + y^2 - 9 = 9y^2 - 9$$

which is satisfied if $y = \pm 1$.

So there are four critical points: $(0, 3)$, $(0, -3)$, $(-2, 1)$ and $(2, -1)$. The classification is

critical point	$f_{xx}f_{yy} - f_{xy}^2$	f_{xx}	type
$(0, 3)$	$(6) \times (0) - (6)^2 < 0$		saddle point
$(0, -3)$	$(-6) \times (0) - (-6)^2 < 0$		saddle point
$(-2, 1)$	$(-10) \times (-4) - (-2)^2 > 0$	-10	local max
$(2, -1)$	$(10) \times (4) - (2)^2 > 0$	10	local min

S-6: To find the critical points we will need the first order partial derivatives of f , and to apply the second derivative test of Theorem 16.1.14 in the text we will need all second order partial derivatives. So we need all partial derivatives of f up to order two. Here they are.

$$\begin{aligned}
 f &= x^2 + y^2 + x^2y + 4 \\
 f_x &= 2x + 2xy & f_{xx} &= 2 + 2y & f_{xy} &= 2x \\
 f_y &= 2y + x^2 & f_{yy} &= 2
 \end{aligned}$$

The first partial derivatives are defined everywhere so the critical points are the solutions of

$$\begin{aligned}
 f_x &= 0 & f_y &= 0 \\
 \iff 2x(1 + y) &= 0 & 2y + x^2 &= 0 \\
 \iff x = 0 \text{ or } y = -1 & & 2y + x^2 &= 0
 \end{aligned}$$

When $x = 0$, y must be 0. When $y = -1$, x^2 must be 2. So, there are three critical points: $(0, 0)$, $(\pm\sqrt{2}, -1)$.

The classification is

critical point	$f_{xx}f_{yy} - f_{xy}^2$	f_{xx}	type
$(0, 0)$	$2 \times 2 - 0^2 > 0$	$2 > 0$	local min
$(\sqrt{2}, -1)$	$0 \times 2 - (2\sqrt{2})^2 < 0$		saddle point
$(-\sqrt{2}, -1)$	$0 \times 2 - (-2\sqrt{2})^2 < 0$		saddle point

S-7: To find the critical points we will need the first order partial derivatives of f , and to apply the second derivative test of Theorem 16.1.14 in the text we will need all second order partial derivatives. So we need all partial derivatives of f up to order two. Here they are.

$$\begin{aligned}
 f &= x^3 + x^2 - 2xy + y^2 - x \\
 f_x &= 3x^2 + 2x - 2y - 1 & f_{xx} &= 6x + 2 & f_{xy} &= -2 \\
 f_y &= -2x + 2y & f_{yy} &= 2 & f_{yx} &= -2
 \end{aligned}$$

(Of course, f_{xy} and f_{yx} have to be the same. It is still useful to compute both, as a way to catch some mechanical errors.)

The first order partial derivatives exist everywhere so the critical points are the solutions of

$$f_x = 3x^2 + 2x - 2y - 1 = 0 \tag{E1}$$

$$f_y = -2x + 2y = 0 \tag{E2}$$

Substituting $y = x$, from (E2), into (E1) gives

$$3x^2 - 1 = 0 \iff x = \pm \frac{1}{\sqrt{3}} = 0$$

So there are two critical points: $\pm\left(\frac{1}{\sqrt{3}}, \frac{1}{\sqrt{3}}\right)$.

The classification is

critical point	$f_{xx}f_{yy} - f_{xy}^2$	f_{xx}	type
$\left(\frac{1}{\sqrt{3}}, \frac{1}{\sqrt{3}}\right)$	$(2\sqrt{3} + 2) \times (2) - (-2)^2 > 0$	$2\sqrt{3} + 2 > 0$	local min
$-\left(\frac{1}{\sqrt{3}}, \frac{1}{\sqrt{3}}\right)$	$(-2\sqrt{3} + 2) \times (2) - (-2)^2 < 0$		saddle point

S-8: To find the critical points we will need the first order partial derivatives of f and to apply the second derivative test of Theorem 16.1.14 in the text we will need all second order partial derivatives. So we need all partial derivatives of f up to order two. Here they are.

$$\begin{aligned}
 f &= x^3 + xy^2 - 3x^2 - 4y^2 + 4 \\
 f_x &= 3x^2 + y^2 - 6x & f_{xx} &= 6x - 6 & f_{xy} &= 2y \\
 f_y &= 2xy - 8y & f_{yy} &= 2x - 8 & f_{yx} &= 2y
 \end{aligned}$$

(Of course, f_{xy} and f_{yx} have to be the same. It is still useful to compute both, as a way to catch some mechanical errors.)

The first partial derivatives exist everywhere so the critical points are the solutions of

$$f_x = 3x^2 + y^2 - 6x = 0 \quad f_y = 2(x-4)y = 0$$

The second equation is satisfied if at least one of $x = 4$, $y = 0$ are satisfied.

- If $x = 4$, the first equation reduces to $y^2 = -24$, which has no real solutions.
- If $y = 0$, the first equation reduces to $3x(x-2) = 0$, which is satisfied if either $x = 0$ or $x = 2$.

So there are two critical points: $(0,0)$, $(2,0)$.

The classification is

critical point	$f_{xx}f_{yy} - f_{xy}^2$	f_{xx}	type
$(0,0)$	$(-6) \times (-8) - (0)^2 > 0$	-6	local max
$(2,0)$	$6 \times (-4) - (0)^2 < 0$		saddle point

S-9: (a) To find the critical points we will need the first order partial derivatives of f and to apply the second derivative test of Theorem 16.1.14 in the text we will need all second order partial derivatives. So we need all partial derivatives of f up to order two. Here they are.

$$\begin{aligned} f &= x^3 + 3xy + 3y^2 - 6x - 3y - 6 \\ f_x &= 3x^2 + 3y - 6 & f_{xx} &= 6x & f_{xy} &= 3 \\ f_y &= 3x + 6y - 3 & f_{yy} &= 6 & f_{yx} &= 3 \end{aligned}$$

The first partial derivatives exist everywhere (as they are polynomials with two variables) and so the first order partial derivatives exist everywhere. So the critical points are the solutions of

$$f_x = 3x^2 + 3y - 6 = 0 \quad f_y = 3x + 6y - 3 = 0$$

Subtracting the second equation from 2 times the first equation gives

$$6x^2 - 3x - 9 = 0 \iff 3(2x-3)(x+1) = 0 \iff x = \frac{3}{2}, -1$$

Since $y = \frac{1-x}{2}$ (from the second equation), the critical points are $(\frac{3}{2}, -\frac{1}{4})$, $(-1, 1)$ and the classification is

critical point	$f_{xx}f_{yy} - f_{xy}^2$	f_{xx}	type
$(\frac{3}{2}, -\frac{1}{4})$	$(9) \times (6) - (3)^2 > 0$	9	local min
$(-1, 1)$	$(-6) \times (6) - (3)^2 < 0$		saddle point

(b) Notice that the lines $x = y$, $x = -y$ and $y = 0$ are all level curves of the function $f(x,y) = y(x+y)(x-y) + 1$ (i.e. of (iii)) with $f = 1$. So the first picture goes with (iii). And the second picture goes with (i).

Here are the pictures with critical points marked on them. There are saddle points where level curves cross and there are local max's or min's at "bull's eyes".

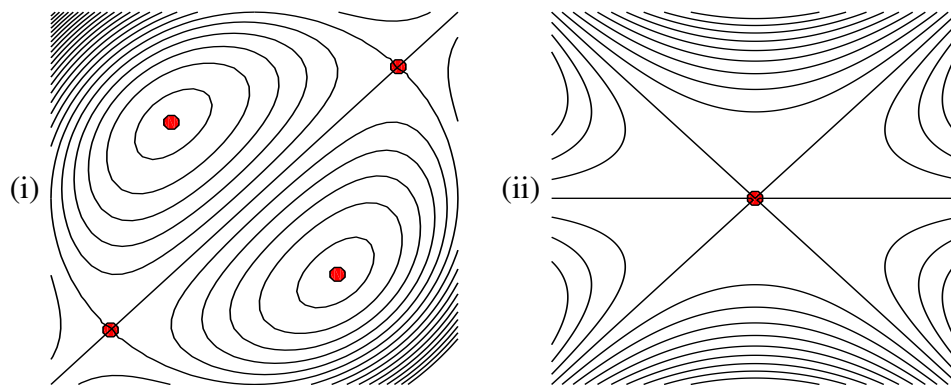

S-10: To find the critical points we will need the first order partial derivatives of f , and to apply the second derivative test of Theorem 16.1.14 in the text we will need all second order partial derivatives. So we need all partial derivatives of f up to order two. Here they are.

$$\begin{aligned}
 f &= x^3 + 3xy + 3y^2 - 6x - 3y - 6 \\
 f_x &= 3x^2 + 3y - 6 & f_{xx} &= 6x & f_{xy} &= 3 \\
 f_y &= 3x + 6y - 3 & f_{yy} &= 6 & f_{yx} &= 3
 \end{aligned}$$

(Of course, f_{xy} and f_{yx} have to be the same. It is still useful to compute both, as a way to catch some mechanical errors.)

The first order partial derivatives are defined everywhere and so the critical points are the solutions of

$$f_x = 3x^2 + 3y - 6 = 0 \tag{E1}$$

$$f_y = 3x + 6y - 3 = 0 \tag{E2}$$

Subtracting equation (E2) from twice equation (E1) gives

$$6x^2 - 3x - 9 = 0 \iff (2x - 3)(3x + 3) = 0$$

So we must have either $x = \frac{3}{2}$ or $x = -1$.

- If $x = \frac{3}{2}$, (E2) reduces to $\frac{9}{2} + 6y - 3 = 0$ so $y = -\frac{1}{4}$.
- If $x = -1$, (E2) reduces to $-3 + 6y - 3 = 0$ so $y = 1$.

So there are two critical points: $(\frac{3}{2}, -\frac{1}{4})$ and $(-1, 1)$.

The classification is

critical point	$f_{xx}f_{yy} - f_{xy}^2$	f_{xx}	type
$(\frac{3}{2}, -\frac{1}{4})$	$(9) \times (6) - (3)^2 > 0$	9	local min
$(-1, 1)$	$(-6) \times (6) - (3)^2 < 0$		saddle point

S-11: Thinking a little way ahead, to find the critical points we will need the first order partial derivatives of f , and to apply the second derivative test of Theorem 16.1.14 in the text we will need

all second order partial derivatives. So we need all partial derivatives of f up to order two. Here they are.

$$\begin{aligned}
 f &= 3x^2y + y^3 - 3x^2 - 3y^2 + 4 \\
 f_x &= 6xy - 6x & f_{xx} &= 6y - 6 & f_{xy} &= 6x \\
 f_y &= 3x^2 + 3y^2 - 6y & f_{yy} &= 6y - 6 & f_{yx} &= 6x
 \end{aligned}$$

(Of course, f_{xy} and f_{yx} have to be the same. It is still useful to compute both, as a way to catch some mechanical errors.)

The first partial derivatives are defined everywhere and so the critical points are the solutions of

$$f_x = 6x(y - 1) = 0 \quad f_y = 3x^2 + 3y^2 - 6y = 0$$

The first equation is satisfied if at least one of $x = 0$, $y = 1$ are satisfied.

- If $x = 0$, the second equation reduces to $3y^2 - 6y = 0$, which is satisfied if either $y = 0$ or $y = 2$.
- If $y = 1$, the second equation reduces to $3x^2 - 3 = 0$ which is satisfied if $x = \pm 1$.

So there are four critical points: $(0,0)$, $(0,2)$, $(1,1)$, $(-1,1)$.

The classification is

critical point	$f_{xx}f_{yy} - f_{xy}^2$	f_{xx}	type
$(0,0)$	$(-6) \times (-6) - (0)^2 > 0$	-6	local max
$(0,2)$	$6 \times 6 - (0)^2 > 0$	6	local min
$(1,1)$	$0 \times 0 - (6)^2 < 0$		saddle point
$(-1,1)$	$0 \times 0 - (-6)^2 < 0$		saddle point

S-12: We have

$$\begin{aligned}
 f(x,y) &= x^4 + y^4 - 4xy + 2 & f_x(x,y) &= 4x^3 - 4y & f_{xx}(x,y) &= 12x^2 \\
 & & f_y(x,y) &= 4y^3 - 4x & f_{yy}(x,y) &= 12y^2 \\
 & & & & f_{xy}(x,y) &= -4
 \end{aligned}$$

The partial first derivatives are defined everywhere. So the critical point are the solutions of

$$\begin{aligned}
 f_x(x,y) = f_y(x,y) = 0 &\iff y = x^3 \text{ and } x = y^3 \\
 &\iff x = x^9 \text{ and } y = x^3 \\
 &\iff x(x^8 - 1) = 0, y = x^3 \\
 &\iff (x,y) = (0,0) \text{ or } (1,1) \text{ or } (-1,-1)
 \end{aligned}$$

Here is a table giving the classification of each of the three critical points.

critical point	$f_{xx}f_{yy} - f_{xy}^2$	f_{xx}	type
$(0,0)$	$0 \times 0 - (-4)^2 < 0$		saddle point
$(1,1)$	$12 \times 12 - (-4)^2 > 0$	12	local min
$(-1,-1)$	$12 \times 12 - (-4)^2 > 0$	12	local min

S-13: We have

$$\begin{aligned}
 f(x,y) = x^4 + y^4 - 4xy & \quad f_x(x,y) = 4x^3 - 4y & \quad f_{xx}(x,y) = 12x^2 \\
 & \quad f_y(x,y) = 4y^3 - 4x & \quad f_{yy}(x,y) = 12y^2 \\
 & & \quad f_{xy}(x,y) = -4
 \end{aligned}$$

The first partial derivatives are defined everywhere. So the critical points are the solution of

$$\begin{aligned}
 f_x(x,y) = f_y(x,y) = 0 & \iff y = x^3 \text{ and } x = y^3 \iff x = x^9 \text{ and } y = x^3 \\
 & \iff x(x^8 - 1) = 0, y = x^3 \\
 & \iff (x,y) = (0,0) \text{ or } (1,1) \text{ or } (-1,-1)
 \end{aligned}$$

Here is a table giving the classification of each of the three critical points.

critical point	$f_{xx}f_{yy} - f_{xy}^2$	f_{xx}	type
(0,0)	$0 \times 0 - (-4)^2 < 0$		saddle point
(1,1)	$12 \times 12 - (-4)^2 > 0$	12	local min
(-1,-1)	$12 \times 12 - (-4)^2 > 0$	12	local min

S-14: We have

$$\begin{aligned}
 f(x,y) = x^3 + xy^2 - x & \quad f_x(x,y) = 3x^2 + y^2 - 1 & \quad f_{xx}(x,y) = 6x \\
 & \quad f_y(x,y) = 2xy & \quad f_{yy}(x,y) = 2x \\
 & & \quad f_{xy}(x,y) = 2y
 \end{aligned}$$

The first partial derivatives are defined everywhere. So the critical points are the solution of

$$\begin{aligned}
 f_x(x,y) = f_y(x,y) = 0 & \iff xy = 0 \text{ and } 3x^2 + y^2 = 1 \\
 & \iff \{x = 0 \text{ or } y = 0\} \text{ and } 3x^2 + y^2 = 1 \\
 & \iff (x,y) = (0,1) \text{ or } (0,-1) \text{ or } \left(\frac{1}{\sqrt{3}},0\right) \text{ or } \left(-\frac{1}{\sqrt{3}},0\right)
 \end{aligned}$$

Here is a table giving the classification of each of the four critical points.

critical point	$f_{xx}f_{yy} - f_{xy}^2$	f_{xx}	type
(0,1)	$0 \times 0 - 2^2 < 0$		saddle point
(0,-1)	$0 \times 0 - (-2)^2 < 0$		saddle point
$(\frac{1}{\sqrt{3}},0)$	$2\sqrt{3} \times \frac{2}{\sqrt{3}} - 0^2 > 0$	$2\sqrt{3}$	local min
$(-\frac{1}{\sqrt{3}},0)$	$-2\sqrt{3} \times (-\frac{2}{\sqrt{3}}) - 0^2 > 0$	$-2\sqrt{3}$	local max

S-15: We have

$$\begin{aligned}
 f(x,y) = x^3 - 3xy^2 - 3x^2 - 3y^2 & \quad f_x(x,y) = 3x^2 - 3y^2 - 6x & \quad f_{xx}(x,y) = 6x - 6 \\
 & \quad f_y(x,y) = -6xy - 6y & \quad f_{yy}(x,y) = -6x - 6 \\
 & & \quad f_{xy}(x,y) = -6y
 \end{aligned}$$

The first partial derivatives are defined everywhere. So the critical points are the solution of

$$\begin{aligned} f_x(x,y) = f_y(x,y) = 0 &\iff 3(x^2 - y^2 - 2x) = 0 \text{ and } -6y(x+1) = 0 \\ &\iff \{x = -1 \text{ or } y = 0\} \text{ and } x^2 - y^2 - 2x = 0 \\ &\iff (x,y) = (-1, \sqrt{3}) \text{ or } (-1, -\sqrt{3}) \text{ or } (0,0) \text{ or } (2,0) \end{aligned}$$

Here is a table giving the classification of each of the four critical points.

critical point	$f_{xx}f_{yy} - f_{xy}^2$	f_{xx}	type
(0,0)	$(-6) \times (-6) - 0^2 > 0$	-6	local max
(2,0)	$6 \times (-18) - 0^2 < 0$		saddle point
$(-1, \sqrt{3})$	$(-12) \times 0 - (-6\sqrt{3})^2 < 0$		saddle point
$(-1, -\sqrt{3})$	$(-12) \times 0 - (6\sqrt{3})^2 < 0$		saddle point

S-16: To find the critical points we will need the first order partial derivatives of f and to apply the second derivative test of Theorem 16.1.14 in the text we will need all second order partial derivatives. So we need all partial derivatives of f up to order two. Here they are.

$$\begin{aligned} f &= 3kx^2y + y^3 - 3x^2 - 3y^2 + 4 \\ f_x &= 6kxy - 6x & f_{xx} &= 6ky - 6 & f_{xy} &= 6kx \\ f_y &= 3kx^2 + 3y^2 - 6y & f_{yy} &= 6y - 6 & f_{yx} &= 6kx \end{aligned}$$

(Of course, f_{xy} and f_{yx} have to be the same. It is still useful to compute both, as a way to catch some mechanical errors.)

The first partial derivatives are defined everywhere. So the critical points are the solution of

$$f_x = 6x(ky - 1) = 0 \quad f_y = 3kx^2 + 3y^2 - 6y = 0$$

The first equation is satisfied if at least one of $x = 0$, $y = 1/k$ are satisfied. (Recall that $k > 0$.)

- If $x = 0$, the second equation reduces to $3y(y - 2) = 0$, which is satisfied if either $y = 0$ or $y = 2$.
- If $y = 1/k$, the second equation reduces to $3kx^2 + \frac{3}{k^2} - \frac{6}{k} = 3kx^2 + \frac{3}{k^2}(1 - 2k) = 0$.

Case $k < \frac{1}{2}$: If $k < \frac{1}{2}$, then $\frac{3}{k^2}(1 - 2k) > 0$ and the equation $3kx^2 + \frac{3}{k^2}(1 - 2k) = 0$ has no real solutions. In this case there are two critical points: (0,0), (0,2) and the classification is

critical point	$f_{xx}f_{yy} - f_{xy}^2$	f_{xx}	type
(0,0)	$(-6) \times (-6) - (0)^2 > 0$	-6	local max
(0,2)	$(12k - 6) \times 6 - (0)^2 < 0$		saddle point

Case $k = \frac{1}{2}$: If $k = \frac{1}{2}$, then $\frac{3}{k^2}(1 - 2k) = 0$ and the equation $3kx^2 + \frac{3}{k^2}(1 - 2k) = 0$ reduces to $3kx^2 = 0$ which has as its only solution $x = 0$. We have already seen this third critical point, $x = 0$, $y = 1/k = 2$. So there are again two critical points: (0,0), (0,2) and the classification is

critical point	$f_{xx}f_{yy} - f_{xy}^2$	f_{xx}	type
(0,0)	$(-6) \times (-6) - (0)^2 > 0$	-6	local max
(0,2)	$(12k - 6) \times 6 - (0)^2 = 0$		unknown

Case $k > \frac{1}{2}$: If $k > \frac{1}{2}$, then $\frac{3}{k^2}(1 - 2k) < 0$ and the equation $3kx^2 + \frac{3}{k^2}(1 - 2k) = 0$ reduces to $3kx^2 = \frac{3}{k^2}(2k - 1)$ which has two solutions, namely $x = \pm\sqrt{\frac{1}{k^3}(2k - 1)}$. So there are four critical points: (0,0), (0,2), $(\sqrt{\frac{1}{k^3}(2k - 1)}, \frac{1}{k})$ and $(-\sqrt{\frac{1}{k^3}(2k - 1)}, \frac{1}{k})$ and the classification is

critical point	$f_{xx}f_{yy} - f_{xy}^2$	f_{xx}	type
(0,0)	$(-6) \times (-6) - (0)^2 > 0$	-6	local max
(0,2)	$(12k - 6) \times 6 - (0)^2 > 0$	$12k - 6 > 0$	local min
$(\sqrt{\frac{1}{k^3}(2k - 1)}, \frac{1}{k})$	$(6 - 6) \times (\frac{6}{k} - 6) - (> 0)^2 < 0$		saddle point
$(-\sqrt{\frac{1}{k^3}(2k - 1)}, \frac{1}{k})$	$(6 - 6) \times (\frac{6}{k} - 6) - (< 0)^2 < 0$		saddle point

S-17: We wish to choose m and b so as to minimize the (square of the) rms error

$$E(m, b) = \sum_{i=1}^n (mx_i + b - y_i)^2.$$

$$0 = \frac{\partial E}{\partial m} = \sum_{i=1}^n 2(mx_i + b - y_i)x_i = m \left[\sum_{i=1}^n 2x_i^2 \right] + b \left[\sum_{i=1}^n 2x_i \right] - \left[\sum_{i=1}^n 2x_i y_i \right]$$

$$0 = \frac{\partial E}{\partial b} = \sum_{i=1}^n 2(mx_i + b - y_i) = m \left[\sum_{i=1}^n 2x_i \right] + b \left[\sum_{i=1}^n 2 \right] - \left[\sum_{i=1}^n 2y_i \right]$$

Here, the first partial derivatives $\frac{\partial E}{\partial m}$ and $\frac{\partial E}{\partial b}$ are defined everywhere and the critical points are the solution of

$$0 = \frac{\partial E}{\partial m} = \sum_{i=1}^n 2(mx_i + b - y_i)x_i = m \left[\sum_{i=1}^n 2x_i^2 \right] + b \left[\sum_{i=1}^n 2x_i \right] - \left[\sum_{i=1}^n 2x_i y_i \right]$$

$$0 = \frac{\partial E}{\partial b} = \sum_{i=1}^n 2(mx_i + b - y_i) = m \left[\sum_{i=1}^n 2x_i \right] + b \left[\sum_{i=1}^n 2 \right] - \left[\sum_{i=1}^n 2y_i \right]$$

There are a lot of symbols in those two equations. But remember that only two of them, namely m and b , are unknowns. All of the x_i 's and y_i 's are given data. We can make the equations look a lot less imposing if we define $S_x = \sum_{i=1}^n x_i$, $S_y = \sum_{i=1}^n y_i$, $S_{x^2} = \sum_{i=1}^n x_i^2$ and $S_{xy} = \sum_{i=1}^n x_i y_i$. In terms of this notation, the two equations are (after dividing by two)

$$S_{x^2} m + S_x b = S_{xy} \tag{1}$$

$$S_x m + n b = S_y \tag{2}$$

This is a system of two linear equations in two unknowns. One way¹ to solve them, is to use one of the two equations to solve for one of the two unknowns in terms of the other unknown. For example, equation (2) gives that

$$b = \frac{1}{n}(S_y - S_x m)$$

1 This procedure is probably not the most efficient one. But it has the advantage that it always works, it does not require any ingenuity on the part of the solver, and it generalizes easily to larger linear systems of equations.

If we now substitute this into equation (1) we get

$$S_{x^2} m + \frac{S_x}{n} (S_y - S_x m) = S_{xy} \implies \left(S_{x^2} - \frac{S_x^2}{n} \right) m = S_{xy} - \frac{S_x S_y}{n}$$

which is a single equation in the single unknown m . We can easily solve it for m . It tells us that

$$m = \frac{nS_{xy} - S_x S_y}{nS_{x^2} - S_x^2}$$

Then substituting this back into $b = \frac{1}{n} (S_y - S_x m)$ gives us

$$b = \frac{S_y}{n} - \frac{S_x}{n} \left(\frac{nS_{xy} - S_x S_y}{nS_{x^2} - S_x^2} \right) = \frac{S_y S_{x^2} - S_x S_{xy}}{nS_{x^2} - S_x^2}$$

Solutions to Exercises 16.2 — Jump to [TABLE OF CONTENTS](#)

S-1: False. A common mistake is to think that the intercepts of a circle are somehow “endpoints,” in the same way that the interval $[-1, 1]$ has endpoints -1 and 1 . But circles don’t have endpoints!

When² we’re finding the extrema of a function over a closed curve, we use the equation of the curve to get a function of one variable. Then we look for critical points and endpoints of that function.

These may *or may not* occur at $x = \pm 1$ or $y = \pm 1$.

Now, you might notice that school problems often end up having their extrema at the extreme values of x and/or y in the boundary. This is a result of writing problems with relatively easy algebra, rather than the result of some universal law.

S-2: The height $\sqrt{x^2 + y^2}$ at (x, y) is the distance from (x, y) to $(0, 0)$. So the minimum height is zero at $(0, 0, 0)$. The surface is a cone. The cone has a point at $(0, 0, 0)$ and the derivatives z_x and z_y do not exist there. The maximum height is achieved when (x, y) is as far as possible from $(0, 0)$. The highest points are at $(\pm 1, \pm 1, \sqrt{2})$. There z_x and z_y exist but are not zero. These points would not be the highest points if it were not for the restriction $|x|, |y| \leq 1$.

S-3: The specified function and its first order derivatives are

$$f(x, y) = xy - x^3 y^2 \quad f_x(x, y) = y - 3x^2 y^2 \quad f_y(x, y) = x - 2x^3 y$$

- First, we find the critical points. The first partial derivatives are defined everywhere and so the critical points are the solution of

$$\begin{aligned} f_x = 0 &\iff y(1 - 3x^2 y) = 0 &\iff y = 0 \text{ or } 3x^2 y = 1 \\ f_y = 0 &\iff x(1 - 2x^2 y) = 0 &\iff x = 0 \text{ or } 2x^2 y = 1 \end{aligned}$$

– If $y = 0$, we cannot have $2x^2 y = 1$, so we must have $x = 0$.

² At least in this section, this is how we do it.. but we’ll learn other ways that also don’t involve optimizing x and y separately

- If $3x^2y = 1$, we cannot have $x = 0$, so we must have $2x^2y = 1$. Dividing gives $1 = \frac{3x^2y}{2x^2y} = \frac{3}{2}$ which is impossible.

So the only critical point in the square is $(0,0)$. There $f = 0$.

- Next, we look at the part of the boundary with $x = 0$. There $f = 0$.
- Next, we look at the part of the boundary with $y = 0$. There $f = 0$.
- Next, we look at the part of the boundary with $x = 1$. There $f = y - y^2$. As $\frac{d}{dy}(y - y^2) = 1 - 2y$, the max and min of $y - y^2$ for $0 \leq y \leq 1$ must occur either at $y = 0$, where $f = 0$, or at $y = \frac{1}{2}$, where $f = \frac{1}{4}$, or at $y = 1$, where $f = 0$.
- Next, we look at the part of the boundary with $y = 1$. There $f = x - x^3$. As $\frac{d}{dx}(x - x^3) = 1 - 3x^2$, the max and min of $x - x^3$ for $0 \leq x \leq 1$ must occur either at $x = 0$, where $f = 0$, or at $x = \frac{1}{\sqrt{3}}$, where $f = \frac{2}{3\sqrt{3}}$, or at $x = 1$, where $f = 0$.

All together, we have the following candidates for max and min.

point	$(0,0)$	$x = 0$	$y = 0$	$(1,0)$	$(1, \frac{1}{2})$	$(1,1)$	$(0,1)$	$(\frac{1}{\sqrt{3}}, 1)$	$(1,1)$
value of f	0	0	0	0	$\frac{1}{4}$	0	0	$\frac{2}{3\sqrt{3}}$	0
	min	min	min	min		min	min	max	min

The largest and smallest values of f in this table are

$$\min = 0 \quad \max = \frac{2}{3\sqrt{3}} \approx 0.385$$

S-4: (a) To find the critical points we will need the first order partial derivatives of h and to apply the second derivative test of Theorem 16.1.14 in the text we will need all second order partial derivatives. So we need all partial derivatives of f up to order two. Here they are.

$$\begin{aligned} h &= y(4 - x^2 - y^2) \\ h_x &= -2xy & h_{xx} &= -2y & h_{xy} &= -2x \\ h_y &= 4 - x^2 - 3y^2 & h_{yy} &= -6y & h_{yx} &= -2x \end{aligned}$$

(Of course, h_{xy} and h_{yx} have to be the same. It is still useful to compute both, as a way to catch some mechanical errors.)

The first partial derivatives are defined everywhere and so the critical points are the solutions of

$$h_x = -2xy = 0 \quad h_y = 4 - x^2 - 3y^2 = 0$$

The first equation is satisfied if at least one of $x = 0$, $y = 0$ are satisfied.

- If $x = 0$, the second equation reduces to $4 - 3y^2 = 0$, which is satisfied if $y = \pm \frac{2}{\sqrt{3}}$.
- If $y = 0$, the second equation reduces to $4 - x^2 = 0$ which is satisfied if $x = \pm 2$.

So there are four critical points: $(0, \frac{2}{\sqrt{3}})$, $(0, -\frac{2}{\sqrt{3}})$, $(2, 0)$, $(-2, 0)$.

The classification is

critical point	$h_{xx}h_{yy} - h_{xy}^2$	h_{xx}	type
$(0, \frac{2}{\sqrt{3}})$	$(\frac{-4}{\sqrt{3}}) \times (\frac{-12}{\sqrt{3}}) - (0)^2 > 0$	$\frac{-4}{\sqrt{3}}$	local max
$(0, -\frac{2}{\sqrt{3}})$	$(\frac{4}{\sqrt{3}}) \times (\frac{12}{\sqrt{3}}) - (0)^2 > 0$	$\frac{4}{\sqrt{3}}$	local min
$(2, 0)$	$0 \times 0 - (-4)^2 < 0$		saddle point
$(-2, 0)$	$0 \times 0 - (4)^2 < 0$		saddle point

(b) The absolute max and min can occur either in the interior of the disk or on the boundary of the disk. The boundary of the disk is the circle $x^2 + y^2 = 1$.

- Any absolute max or min in the interior of the disk must also be a local max or min and, must also be a critical point of h . We found all of the critical points of h in part (a). Since $2 > 1$ and $\frac{2}{\sqrt{3}} > 1$ none of the critical points are in the disk.
- At each point of $x^2 + y^2 = 1$ we have $h(x, y) = 3y$ with $-1 \leq y \leq 1$. Clearly the maximum value is 3 (at $(0, 1)$) and the minimum value is -3 (at $(0, -1)$).

So all together, the maximum and minimum values of $h(x, y)$ in $x^2 + y^2 \leq 1$ are 3 (at $(0, 1)$) and -3 (at $(0, -1)$), respectively.

S-5: The maximum and minimum must either occur at a critical point or on the boundary of R .

- The critical points are the points where the first order partial derivatives are zero or one does not exist. Here $f_x(x, y) = 2 - 2x$ and $f_y(x, y) = -8y$ and so they are defined everywhere. Therefore, the critical points are the solutions of

$$\begin{aligned} 0 &= f_x(x, y) = 2 - 2x \\ 0 &= f_y(x, y) = -8y \end{aligned}$$

So the only critical point is $(1, 0)$.

- On the side $x = -1$, $-1 \leq y \leq 1$ of the boundary of R

$$f(-1, y) = 2 - 4y^2$$

This function decreases as $|y|$ increases. So its maximum value on $-1 \leq y \leq 1$ is achieved at $y = 0$ and its minimum value is achieved at $y = \pm 1$.

- On the side $x = 3$, $-1 \leq y \leq 1$ of the boundary of R

$$f(3, y) = 2 - 4y^2$$

This function decreases as $|y|$ increases. So its maximum value on $-1 \leq y \leq 1$ is achieved at $y = 0$ and its minimum value is achieved at $y = \pm 1$.

- On both sides $y = \pm 1$, $-1 \leq x \leq 3$ of the boundary of R

$$f(x, \pm 1) = 1 + 2x - x^2 = 2 - (x - 1)^2$$

This function decreases as $|x - 1|$ increases. So its maximum value on $-1 \leq x \leq 3$ is achieved at $x = 1$ and its minimum value is achieved at $x = 3$ and $x = -1$ (both of whom are a distance 2 from $x = 1$).

So we have the following candidates for the locations of the min and max

point	(1,0)	(-1,0)	(1,±1)	(-1,±1)	(3,0)	(3,±1)
value of f	6	2	2	-2	2	-2
	max			min		min

So the minimum is -2 and the maximum is 6.

S-6: Since $\nabla h = \langle -4, -2 \rangle$ exists and is never zero, h has no critical points and the minimum of h on the disk $x^2 + y^2 \leq 1$ must be taken on the boundary, $x^2 + y^2 = 1$, of the disk.

To find the minimum on the boundary, we need to use the equation $x^2 + y^2 \leq 1$ to turn $h(x, y)$ into a function of one variable. We can break the boundary up into two pieces: $y = \sqrt{1 - x^2}$, $-1 \leq x \leq 1$, and $y = -\sqrt{1 - x^2}$, $-1 \leq x \leq 1$.

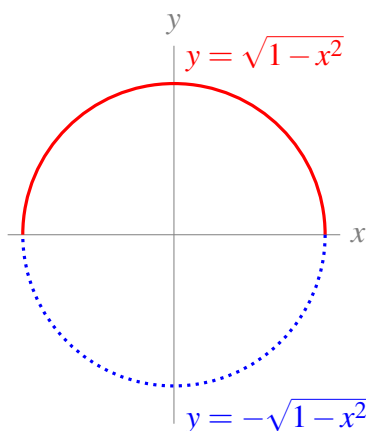

- Define $g_1(x)$ as the value of h along the boundary curve $y = \sqrt{1 - x^2}$, $-1 \leq x \leq 1$.

$$\begin{aligned} g_1(x) &= h\left(x, \sqrt{1 - x^2}\right) = -4x - 2 \left(\underbrace{\sqrt{1 - x^2}}_y \right) + 6 \\ &= -4x - 2\sqrt{1 - x^2} + 6 \end{aligned}$$

To find the minimum of $g_1(x)$, we first find its critical points.

$$\begin{aligned}g_1'(x) &= -4 - 2\left(\frac{-2x}{2\sqrt{1-x^2}}\right) = -4 + \frac{2x}{\sqrt{1-x^2}} \\0 &= -4 + \frac{2x}{\sqrt{1-x^2}} \\4 &= \frac{2x}{\sqrt{1-x^2}} \\2\sqrt{1-x^2} &= x\end{aligned}\tag{*}$$

Squaring both sides,

$$\begin{aligned}4(1-x^2) &= x^2 \\4 &= 5x^2 \\ \frac{4}{5} &= x^2 \\x &= \pm \frac{2}{\sqrt{5}}\end{aligned}$$

From line (*), we see x must be positive, so the only one of these roots that actually solves our equation is the positive one

$$x = \frac{2}{\sqrt{5}}$$

So, the minimum of $g_1(x)$ will occur at its CP $x = \frac{2}{\sqrt{5}}$ or at an endpoint $x = 1$ or $x = -1$.

$$\begin{aligned}g_1(-1) &= -4(-1) - 2\sqrt{1-1} + 6 = 10 \\g_1(1) &= -4(1) - 2\sqrt{1-1} + 6 = 2 \\g_1\left(\frac{2}{\sqrt{5}}\right) &= -4\left(\frac{2}{\sqrt{5}}\right) - 2\sqrt{1-\left(\frac{2}{\sqrt{5}}\right)^2} + 6 \\&= -\frac{8}{\sqrt{5}} - 2\sqrt{\frac{1}{5}} + 6 \\&= -\frac{10}{\sqrt{5}} + 6 \\&= -2\sqrt{5} + 6 \approx 1.53\end{aligned}$$

So the minimum of $g_1(x)$ is $g_1\left(\frac{2}{\sqrt{5}}\right) = 6 - 2\sqrt{5}$.

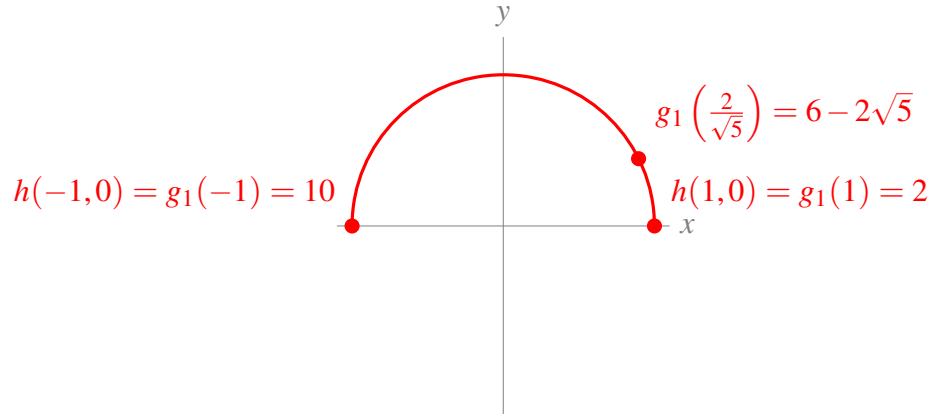

- Define $g_2(x)$ as the value of h along the boundary curve $y = -\sqrt{1-x^2}$, $-1 \leq x \leq 1$.

$$\begin{aligned} g_2(x) &= h\left(x, -\sqrt{1-x^2}\right) = -4x - 2\left(-\sqrt{1-x^2}\right) + 6 \\ &= -4x + 2\sqrt{1-x^2} + 6 \end{aligned}$$

$$\begin{aligned} g_2'(x) &= -4 + 2\left(\frac{-2x}{2\sqrt{1-x^2}}\right) \\ &= -4 - \frac{2x}{\sqrt{1-x^2}} \end{aligned}$$

$$4 = -\frac{2x}{\sqrt{1-x^2}}$$

$$-2\sqrt{1-x^2} = x \tag{*}$$

$$4(1-x^2) = x^2$$

$$4 = 5x^2$$

$$x = \pm \frac{2}{\sqrt{5}}$$

From line (*), we see that x must be negative, so the only solution that works is the negative one

$$x = -\frac{2}{\sqrt{5}}$$

We see that the minimum of $g_2(x)$ will occur at its sole critical point $x = -\frac{2}{\sqrt{5}}$, or at its endpoints $x = \pm 1$.

$$g_2(-1) = -4(-1) + 2\sqrt{1-(-1)^2} + 6 = 4 + 6 = 10$$

$$g_2(1) = -4(1) + 2\sqrt{1-(1)^2} + 6 = -4 + 6 = 2$$

$$g_2\left(-\frac{2}{\sqrt{5}}\right) = -4\left(-\frac{2}{\sqrt{5}}\right) + 2\sqrt{1-\left(-\frac{2}{\sqrt{5}}\right)^2} + 6$$

$$= \frac{8}{\sqrt{5}} + 2\sqrt{\frac{1}{5}} + 6 = \frac{10}{\sqrt{5}} + 6$$

$$= 2\sqrt{5} + 6 \approx 10.47$$

So, the minimum of $g_2(x)$ is $g_2(1) = 2$.

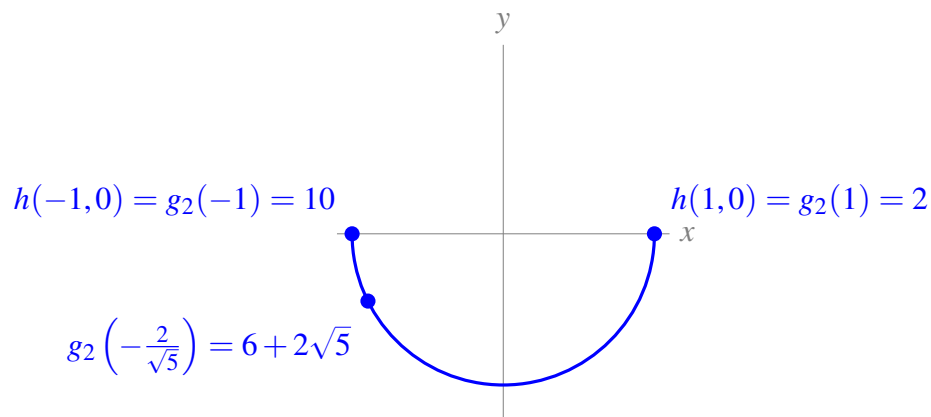

All together, the minimum value h achieves over the boundary $x^2 + y^2 = 1$ is $6 - 2\sqrt{5}$. Since we already decided the global minimum would occur on the boundary, that tells us our global minimum is $6 - 2\sqrt{5}$.

S-7: (a) Thinking a little way ahead, to find the critical points we will need the first order partial derivatives of f and to apply the second derivative test of Theorem 16.1.14 in the text we will need all second order partial derivatives. So we need all partial derivatives of f up to order two. Here they are.

$$\begin{aligned} f &= xy(x + y - 3) \\ f_x &= 2xy + y^2 - 3y & f_{xx} &= 2y & f_{xy} &= 2x + 2y - 3 \\ f_y &= x^2 + 2xy - 3x & f_{yy} &= 2x & f_{yx} &= 2x + 2y - 3 \end{aligned}$$

(Of course, f_{xy} and f_{yx} have to be the same. It is still useful to compute both, as a way to catch some mechanical errors.)

The first order partial derivatives are defined everywhere and so the critical points are the solutions of

$$f_x = y(2x + y - 3) = 0 \quad f_y = x(x + 2y - 3) = 0$$

The first equation is satisfied if at least one of $y = 0$, $y = 3 - 2x$ are satisfied.

- If $y = 0$, the second equation reduces to $x(x - 3) = 0$, which is satisfied if either $x = 0$ or $x = 3$.
- If $y = 3 - 2x$, the second equation reduces to $x(x + 6 - 4x - 3) = x(3 - 3x) = 0$ which is satisfied if $x = 0$ or $x = 1$.

So there are four critical points: $(0, 0)$, $(3, 0)$, $(0, 3)$, $(1, 1)$.

The classification is

critical point	$f_{xx}f_{yy} - f_{xy}^2$	f_{xx}	type
(0,0)	$0 \times 0 - (-3)^2 < 0$		saddle point
(3,0)	$0 \times 6 - (3)^2 < 0$		saddle point
(0,3)	$6 \times 0 - (3)^2 < 0$		saddle point
(1,1)	$2 \times 2 - (1)^2 > 0$	2	local min

(b) The absolute max and min can occur either in the interior of the triangle or on the boundary of the triangle. The boundary of the triangle consists of the three line segments.

$$L_1 = \{ (x,y) \mid x = 0, 0 \leq y \leq 8 \}$$

$$L_2 = \{ (x,y) \mid y = 0, 0 \leq x \leq 8 \}$$

$$L_3 = \{ (x,y) \mid x + y = 8, 0 \leq x \leq 8 \}$$

- Any absolute max or min in the interior of the triangle must also be a local max or min and, must also be a critical point of f . We found all of the critical points of f in part (a). Only one of them, namely (1, 1) is in the interior of the triangle. (The other three critical points are all on the boundary of the triangle.) We have $f(1, 1) = -1$.
- At each point of L_1 we have $x = 0$ and so $f(x, y) = 0$.
- At each point of L_2 we have $y = 0$ and so $f(x, y) = 0$.
- At each point of L_3 we have $f(x, y) = x(8 - x)(5) = 40x - 5x^2 = 5[8x - x^2]$ with $0 \leq x \leq 8$. As $\frac{d}{dx}(40x - 5x^2) = 40 - 10x$, the max and min of $40x - 5x^2$ on $0 \leq x \leq 8$ must be one of $5[8x - x^2]_{x=0} = 0$ or $5[8x - x^2]_{x=8} = 0$ or $5[8x - x^2]_{x=4} = 80$.

So all together, we have the following candidates for max and min, with the max and min indicated.

point(s)	(1, 1)	L_1	L_2	(0, 8)	(8, 0)	(4, 4)
value of f	-1	0	0	0	0	80
	min					max

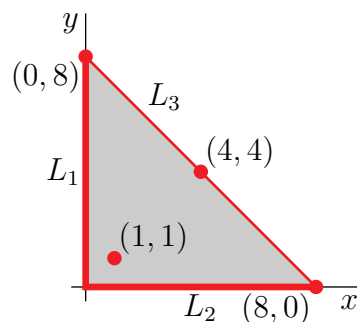

S-8: (a) Since

$$f = 2x^3 - 6xy + y^2 + 4y$$

$$f_x = 6x^2 - 6y \quad f_{xx} = 12x \quad f_{xy} = -6$$

$$f_y = -6x + 2y + 4 \quad f_{yy} = 2$$

the first order partial derivatives are defined everywhere and the critical points are the solutions of

$$f_x = 0 \quad f_y = 0$$

$$\iff y = x^2 \quad y - 3x + 2 = 0$$

$$\iff y = x^2 \quad x^2 - 3x + 2 = 0$$

$$\iff y = x^2 \quad x = 1 \text{ or } 2$$

So, there are two critical points: $(1, 1)$, $(2, 4)$.

critical point	$f_{xx}f_{yy} - f_{xy}^2$	f_{xx}	type
$(1, 1)$	$12 \times 2 - (-6)^2 < 0$		saddle point
$(2, 4)$	$24 \times 2 - (-6)^2 > 0$	24	local min

(b) There are no critical points in the interior of the allowed region, so both the maximum and the minimum occur only on the boundary. The boundary consists of the line segments (i) $x = 1$, $0 \leq y \leq 1$, (ii) $y = 1$, $0 \leq x \leq 1$ and (iii) $y = 1 - x$, $0 \leq x \leq 1$.

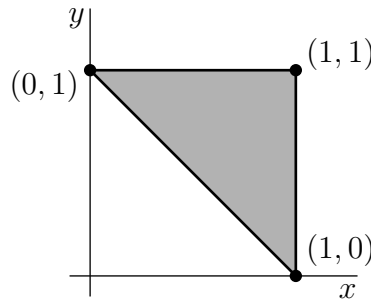

- First, we look at the part of the boundary with $x = 1$. There $f = y^2 - 2y + 2$. As $\frac{d}{dy}(y^2 - 2y + 2) = 2y - 2$ vanishes only at $y = 1$, the max and min of $y^2 - 2y + 2$ for $0 \leq y \leq 1$ must occur either at $y = 0$, where $f = 2$, or at $y = 1$, where $f = 1$.
- Next, we look at the part of the boundary with $y = 1$. There $f = 2x^3 - 6x + 5$. As $\frac{d}{dx}(2x^3 - 6x + 5) = 6x^2 - 6$, the max and min of $2x^3 - 6x + 5$ for $0 \leq x \leq 1$ must occur either at $x = 0$, where $f = 5$, or at $x = 1$, where $f = 1$.
- Next, we look at the part of the boundary with $y = 1 - x$. There $f = 2x^3 - 6x(1 - x) + (1 - x)^2 + 4(1 - x) = 2x^3 + 7x^2 - 12x + 5$. As $\frac{d}{dx}(2x^3 + 7x^2 - 12x + 5) = 6x^2 + 14x - 12 = 2(3x^2 + 7x - 6) = 2(3x - 2)(x + 3)$, the max and min of $2x^3 + 7x^2 - 12x + 5$ for $0 \leq x \leq 1$ must occur either at $x = 0$, where $f = 5$, or at $x = 1$, where $f = 2$, or at $x = \frac{2}{3}$, where $f = 2(\frac{8}{27}) - 6(\frac{2}{3})(\frac{1}{3}) + \frac{1}{9} + \frac{4}{3} = \frac{16 - 36 + 3 + 36}{27} = \frac{19}{27}$.

So all together, we have the following candidates for max and min, with the max and min indicated.

point	$(1, 0)$	$(1, 1)$	$(0, 1)$	$(\frac{2}{3}, \frac{1}{3})$
value of f	2	1	5	$\frac{19}{27}$
			max	min

S-9: (a) We have

$$\begin{aligned}
 f(x, y) &= xy(x + 2y - 6) & f_x(x, y) &= 2xy + 2y^2 - 6y & f_{xx}(x, y) &= 2y \\
 & & f_y(x, y) &= x^2 + 4xy - 6x & f_{yy}(x, y) &= 4x \\
 & & & & f_{xy}(x, y) &= 2x + 4y - 6
 \end{aligned}$$

The first partial derivatives are defined everywhere. So the critical points are the solution of

$$\begin{aligned}
 f_x(x,y) = f_y(x,y) = 0 &\iff 2y(x+y-3) = 0 \text{ and } x(x+4y-6) = 0 \\
 &\iff \{y = 0 \text{ or } x+y = 3\} \text{ and } \{x = 0 \text{ or } x+4y = 6\} \\
 &\iff \{x = y = 0\} \text{ or } \{y = 0, x+4y = 6\} \\
 &\quad \text{or } \{x+y = 3, x = 0\} \text{ or } \{x+y = 3, x+4y = 6\} \\
 &\iff (x,y) = (0,0) \text{ or } (6,0) \text{ or } (0,3) \text{ or } (2,1)
 \end{aligned}$$

Here is a table giving the classification of each of the four critical points.

critical point	$f_{xx}f_{yy} - f_{xy}^2$	f_{xx}	type
(0,0)	$0 \times 0 - (-6)^2 < 0$		saddle point
(6,0)	$0 \times 24 - 6^2 < 0$		saddle point
(0,3)	$6 \times 0 - 6^2 < 0$		saddle point
(2,1)	$2 \times 8 - 2^2 > 0$	2	local min

(b) Observe that $xy = 4$ and $x + 2y = 6$ intersect when $x = 6 - 2y$ and

$$\begin{aligned}
 (6 - 2y)y = 4 &\iff 2y^2 - 6y + 4 = 0 \iff 2(y - 1)(y - 2) = 0 \\
 &\iff (x,y) = (4,1) \text{ or } (2,2)
 \end{aligned}$$

The shaded region in the sketch below is D .

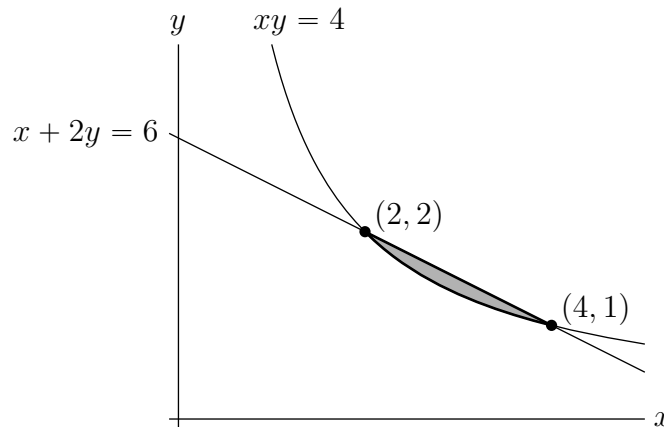

None of the critical points are in D . So the max and min must occur at either $(2,2)$ or $(4,1)$ or on $xy = 4$, $2 < x < 4$ (in which case $F(x) = f(x, \frac{4}{x}) = 4(x + \frac{8}{x} - 6)$ obeys

$F'(x) = 4 - \frac{32}{x^2} = 0 \iff x = \pm 2\sqrt{2}$) or on $x + 2y = 6$, $2 < x < 4$ (in which case $f(x,y)$ is identically zero). So the min and max must occur at one of

(x,y)	$f(x,y)$
(2,2)	$2 \times 2(2 + 2 \times 2 - 6) = 0$
(4,1)	$4 \times 1(4 + 2 \times 1 - 6) = 0$
$(2\sqrt{2}, \sqrt{2})$	$4(2\sqrt{2} + 2\sqrt{2} - 6) < 0$

The maximum value is 0 and the minimum value is $4(4\sqrt{2} - 6) \approx -1.37$.

S-10: The coldest point must be either on the boundary of the plate or in the interior of the plate.

- On the semi-circular part of the boundary $0 \leq y \leq 2$ and $x^2 + y^2 = 4$ so that $T = \ln(1 + x^2 + y^2) - y = \ln 5 - y$. The smallest value of $\ln 5 - y$ is taken when y is as large as possible, i.e. when $y = 2$, and is $\ln 5 - 2 \approx -0.391$.
- On the flat part of the boundary, $y = 0$ and $-2 \leq x \leq 2$ so that $T = \ln(1 + x^2 + y^2) - y = \ln(1 + x^2)$. The smallest value of $\ln(1 + x^2)$ is taken when x is as small as possible, i.e. when $x = 0$, and is 0.
- If the coldest point is in the interior of the plate, it must be at a critical point of $T(x, y)$. Since

$$T_x(x, y) = \frac{2x}{1 + x^2 + y^2} \quad T_y(x, y) = \frac{2y}{1 + x^2 + y^2} - 1$$

a critical point must have $x = 0$ and $\frac{2y}{1 + x^2 + y^2} - 1 = 0$, which is the case if and only if $x = 0$ and $2y - 1 - y^2 = 0$. So the only critical point is $x = 0, y = 1$, where $T = \ln 2 - 1 \approx -0.307$.

Since $-0.391 < -0.307 < 0$, the coldest temperature is -0.391 and the coldest point is $(0, 2)$.

S-11: (a) We have

$$\begin{aligned} g(x, y) &= x^2 - 10y - y^2 & g_x(x, y) &= 2x & g_{xx}(x, y) &= 2 \\ & & g_y(x, y) &= -10 - 2y & g_{yy}(x, y) &= -2 \\ & & & & g_{xy}(x, y) &= 0 \end{aligned}$$

The first partial derivatives are defined everywhere. So the critical points are the solution of

$$g_x(x, y) = g_y(x, y) = 0 \iff 2x = 0 \text{ and } -10 - 2y = 0 \iff (x, y) = (0, -5)$$

Since $g_{xx}(0, -5)g_{yy}(0, -5) - g_{xy}(0, -5)^2 = 2 \times (-2) - 0^2 < 0$, the critical point is a saddle point.

(b) The extrema must be either on the boundary of the region or in the interior of the region.

- On the semi-elliptical part of the boundary $-2 \leq y \leq 0$ and $x^2 + 4y^2 = 16$ so that $g = x^2 - 10y - y^2 = 16 - 10y - 5y^2 = 21 - 5(y + 1)^2$. This has a minimum value of 16 (at $y = 0, -2$) and a maximum value of 21 (at $y = -1$). You could also come to this conclusion by checking the critical point of $16 - 10y - 5y^2$ (i.e. solving $\frac{d}{dy}(16 - 10y - 5y^2) = 0$) and checking the end points of the allowed interval (namely $y = 0$ and $y = -2$).
- On the flat part of the boundary $y = 0$ and $-4 \leq x \leq 4$ so that $g = x^2$. The smallest value is taken when $x = 0$ and is 0 and the largest value is taken when $x = \pm 4$ and is 16.
- If an extremum is in the interior of the plate, it must be at a critical point of $g(x, y)$. The only critical point is not in the prescribed region.

Here is a table giving all candidates for extrema:

(x, y)	$g(x, y)$
$(0, -2)$	16
$(\pm 4, 0)$	16
$(\pm \sqrt{12}, -1)$	21
$(0, 0)$	0

From the table the smallest value of g is 0 at $(0,0)$ and the largest value is 21 at $(\pm 2\sqrt{3}, -1)$.

S-12: Suppose that the bends are made a distance x from the ends of the fence and that the bends are through an angle θ . Here is a sketch of the enclosure.

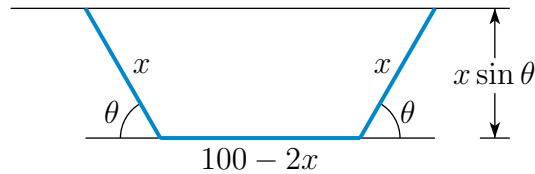

It consists of a rectangle, with side lengths $100 - 2x$ and $x \sin \theta$, together with two triangles, each of height $x \sin \theta$ and base length $x \cos \theta$. So the enclosure has area

$$\begin{aligned} A(x, \theta) &= (100 - 2x)x \sin \theta + 2 \cdot \frac{1}{2} \cdot x \sin \theta \cdot x \cos \theta \\ &= (100x - 2x^2) \sin \theta + \frac{1}{2} x^2 \sin(2\theta) \end{aligned}$$

To maximize the area, we need find the critical points.

$$\begin{aligned} A_x &= (100 - 4x) \sin \theta + x \sin(2\theta) \\ A_\theta &= (100x - 2x^2) \cos \theta + x^2 \cos(2\theta) \end{aligned}$$

Note that A_x and A_θ are defined everywhere in their domain and so to find the critical points we only need to find the points where the first order partial derivatives are zero.

$$\begin{aligned} 0 = A_x &= (100 - 4x) \sin \theta + x \sin(2\theta) &\implies & (100 - 4x) + 2x \cos \theta = 0 \\ 0 = A_\theta &= (100x - 2x^2) \cos \theta + x^2 \cos(2\theta) &\implies & (100 - 2x) \cos \theta + x \cos(2\theta) = 0 \end{aligned}$$

Here we have used that the fence of maximum area cannot have $\sin \theta = 0$ or $x = 0$, because in either of these two cases, the area enclosed will be zero. The first equation forces $\cos \theta = -\frac{100-4x}{2x}$ and hence $\cos(2\theta) = 2 \cos^2 \theta - 1 = \frac{(100-4x)^2}{2x^2} - 1$. Substituting these into the second equation gives

$$\begin{aligned} &-(100 - 2x) \frac{100 - 4x}{2x} + x \left[\frac{(100 - 4x)^2}{2x^2} - 1 \right] = 0 \\ \implies &-(100 - 2x)(100 - 4x) + (100 - 4x)^2 - 2x^2 = 0 \\ \implies &6x^2 - 200x = 0 \\ \implies &x = \frac{100}{3} \quad \cos \theta = -\frac{100/3}{200/3} = -\frac{1}{2} \quad \theta = 60^\circ \\ A &= \left(100 \frac{100}{3} - 2 \frac{100^2}{3^2} \right) \frac{\sqrt{3}}{2} + \frac{1}{2} \frac{100^2}{3^2} \frac{\sqrt{3}}{2} = \frac{2500}{\sqrt{3}} \end{aligned}$$

S-13: Suppose that the box has side lengths x , y and z . Here is a sketch.

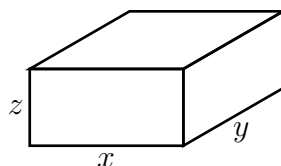

Because the box has to have volume V we need that $V = xyz$. We wish to minimize the area $A = xy + 2yz + 2xz$ of the four sides and bottom. Substituting in $z = \frac{V}{xy}$,

$$A = xy + 2\frac{V}{x} + 2\frac{V}{y}$$

$$A_x = y - 2\frac{V}{x^2}$$

$$A_y = x - 2\frac{V}{y^2}$$

To minimize, we want $A_x = A_y = 0$, which is the case when $yx^2 = 2V$, $xy^2 = 2V$. This forces $yx^2 = xy^2$. Since $V = xyz$ is nonzero, neither x nor y may be zero. So $x = y = (2V)^{1/3}$, $z = 2^{-2/3}V^{1/3}$.

S-14: (a) The maximum and minimum can occur either in the interior of the disk or on the boundary of the disk. The boundary of the disk is the circle $x^2 + y^2 = 4$.

- Any absolute max or min in the interior of the disk must also be a local max or min and must also be a critical point of h . Since $T_x = -8x$ and $T_y = -2y$, the only critical point is $(x, y) = (0, 0)$, where $T = 20$. Since $4x^2 + y^2 \geq 0$, we have $T(x, y) = 20 - 4x^2 - y^2 \leq 20$. So the maximum value of T (even in \mathbb{R}^2) is 20.
- At each point of $x^2 + y^2 = 4$ we have $T(x, y) = 20 - 4x^2 - y^2 = 20 - 4x^2 - (4 - x^2) = 16 - 3x^2$ with $-2 \leq x \leq 2$. So T is a minimum when x^2 is a maximum. Thus the minimum value of T on the disk is $16 - 3(\pm 2)^2 = 4$.

So all together, the maximum and minimum values of $T(x, y)$ in $x^2 + y^2 \leq 4$ are 20 (at $(0, 0)$) and 4 (at $(\pm 2, 0)$), respectively.

(b) We are being asked to find the $(x, y) = (x, 2 - x^2)$ which maximizes

$$T(x, 2 - x^2) = 20 - 4x^2 - (2 - x^2)^2 = 16 - x^4$$

The maximum of $16 - x^4$ is obviously 16 at $x = 0$. So the ant should go to $(0, 2 - 0^2) = (0, 2)$.

S-15: The region of interest is

$$D = \{ (x, y, z) \mid x \geq 0, y \geq 0, z \geq 0, 2x + y + z = 5 \}$$

First observe that, on the boundary of this region, at least one of x , y and z is zero. So $f(x, y, z) = x^2y^2z$ is zero on the boundary. As f takes values which are strictly bigger than zero at all points of D that are not on the boundary, the minimum value of f is 0 on

$$\partial D = \{ (x, y, z) \mid x \geq 0, y \geq 0, z \geq 0, 2x + y + z = 5, \text{ at least one of } x, y, z \text{ zero} \}$$

The maximum value of f will be taken at a critical point. On D

$$f = x^2y^2(5 - 2x - y) = 5x^2y^2 - 2x^3y^2 - x^2y^3$$

So the critical points are the solutions of

$$\begin{aligned}0 &= f_x(x, y) = 10xy^2 - 6x^2y^2 - 2xy^3 \\0 &= f_y(x, y) = 10x^2y - 4x^3y - 3x^2y^2\end{aligned}$$

(note that the first order partial derivatives are defined everywhere) or, dividing by the first equation by xy^2 and the second equation by x^2y , (recall that $x, y \neq 0$)

$$\begin{aligned}10 - 6x - 2y &= 0 & \text{or} & & 3x + y &= 5 \\10 - 4x - 3y &= 0 & \text{or} & & 4x + 3y &= 10\end{aligned}$$

Substituting $y = 5 - 3x$, from the first equation, into the second equation gives

$$4x + 3(5 - 3x) = 10 \implies -5x + 15 = 10 \implies x = 1, y = 5 - 3(1) = 2$$

So the maximum value of f is $(1)^2(2)^2(5 - 2 - 2) = 4$ at $(1, 2, 1)$.

S-16: (a) For $x, y > 0$, f_x and f_y are well-defined and so the critical points are the solutions of

$$\begin{aligned}f_x &= 2 - \frac{1}{x^2y} = 0 \iff y = \frac{1}{2x^2} \\f_y &= 4 - \frac{1}{xy^2} = 0\end{aligned}$$

Substituting $y = \frac{1}{2x^2}$, from the first equation, into the second gives $4 - 4x^3 = 0$ which forces $x = 1$, $y = \frac{1}{2}$. At $x = 1, y = \frac{1}{2}$,

$$f\left(1, \frac{1}{2}\right) = 2 + 2 + 2 = 6$$

(b) The second derivatives are

$$f_{xx}(x, y) = \frac{2}{x^3y} \quad f_{xy}(x, y) = \frac{1}{x^2y^2} \quad f_{yy}(x, y) = \frac{2}{xy^3}$$

In particular

$$f_{xx}\left(1, \frac{1}{2}\right) = 4 \quad f_{xy}\left(1, \frac{1}{2}\right) = 4 \quad f_{yy}\left(1, \frac{1}{2}\right) = 16$$

Since $f_{xx}\left(1, \frac{1}{2}\right)f_{yy}\left(1, \frac{1}{2}\right) - f_{xy}\left(1, \frac{1}{2}\right)^2 = 4 \times 16 - 4^2 = 48 > 0$ and $f_{xx}\left(1, \frac{1}{2}\right) = 4 > 0$, the point $\left(1, \frac{1}{2}\right)$ is a local minimum.

(c) As x or y tends to infinity (with the other at least zero), $2x + 4y$ tends to $+\infty$. As (x, y) tends to any point on the first quadrant part of the x - and y -axes, $\frac{1}{xy}$ tends to $+\infty$. Hence as x or y tends to the boundary of the first quadrant (counting infinity as part of the boundary), $f(x, y)$ tends to $+\infty$. As a result $\left(1, \frac{1}{2}\right)$ is a global (and not just local) minimum for f in the first quadrant. Hence $f(x, y) \geq f\left(1, \frac{1}{2}\right) = 6$ for all $x, y > 0$.

S-17: First, let's visualize what's going on. Our surface looks like a bowl, sitting on the origin, opening upwards. It is radially symmetric about the z -axis, with circular level curves. That means every point on a level curve is equidistant from the z -axis. Since the point $(0, 0, a)$ is on the z -axis, if there is a point (x, y, z) that has minimum distance to the point, then its entire level curve has the

same minimum distance. So we expect our answer to look like a circle (or possibly a single point – a “circle” of radius 0). If a is a negative number, it seems natural that the closest point would be $(0,0,0)$.

The distance from $(0,0,a)$ to an arbitrary point (x,y,z) is $\sqrt{x^2 + y^2 + (z-a)^2}$. If the point (x,y,z) is on our surface, then $z = x^2 + y^2$. Rather than deal with square roots, we’ll minimize the distance squared:

$$f(x,y) = x^2 + y^2 + (x^2 + y^2 - a)^2$$

From our observations above, there will be no global maximum; the global minimum will be a local minimum; the global minimum will depend on a in a less-than-simple way; and there are likely to be multiple points that are all minimum distance to $(0,0,a)$.

We start by finding critical points.

$$\begin{aligned} f_x(x,y) &= 2x + 2x \cdot 2(x^2 + y^2 - a) \\ &= 2x(1 + 2(x^2 + y^2 - a)) \\ &= 4x\left(x^2 + y^2 + \frac{1}{2} - a\right) \\ f_y(x,y) &= 2y + 2y \cdot 2(x^2 + y^2 - a) \\ &= 2y(1 + 2(x^2 + y^2 - a)) \\ &= 4y\left(x^2 + y^2 + \frac{1}{2} - a\right) \end{aligned}$$

- For any value of a , $(x,y) = (0,0)$ is a critical point.
- If $a < \frac{1}{2}$, then the only critical point is $(x,y) = (0,0)$.
- If $a \geq \frac{1}{2}$, then all points on the level curve $x^2 + y^2 = a - \frac{1}{2}$ are critical points.

So if $a < \frac{1}{2}$, we’re done: the single closest point on the surface is $(0,0,0)$.

Suppose $a \geq \frac{1}{2}$. Now we need to decide whether $(0,0,a)$ is closer to the origin or to a point on the level curve $x^2 + y^2 = a - \frac{1}{2}$.

- $f(0,0) = 0 + 0 + (0 - a)^2 = a^2$
- If $x^2 + y^2 = a - \frac{1}{2}$, then:

$$\begin{aligned} f(x,y) &= x^2 + y^2 + (x^2 + y^2 - a)^2 \\ &= \left(a - \frac{1}{2}\right) + \left(a - \frac{1}{2} - a\right)^2 \\ &= \left(a - \frac{1}{2}\right) + \frac{1}{4} \\ &= a - \frac{1}{4} \end{aligned}$$

- All together, the origin is closer than the level curve when:

$$a^2 < a - \frac{1}{4}$$

$$a^2 - a + \frac{1}{4} < 0$$

$$\left(a - \frac{1}{2}\right)^2 < 0$$

which never happens. So the origin is never closer than the level curve, again provided $a \geq \frac{1}{2}$.

So, all together: if $a < \frac{1}{2}$, then the closest point is the origin. If $a \geq \frac{1}{2}$, then the closest points are the level curve where $z = a - \frac{1}{2}$.

S-18:

- (a) Let us first find the profit equations for each of the paper sizes separately and then we sum them up to get the total profit function.

$$\Pi_4(x) = f(x)(6) - x(1) = 15x^{0.8} - x \quad (\text{profit for A4})$$

$$\Pi_3(y) = g(y)(8) - y(3) = 80y^{0.6} - 3y \quad (\text{profit for A3})$$

and therefore, the total profit equation is given by

$$\begin{aligned} \Pi(x, y) &= \Pi_4(x) + \Pi_3(y) \\ &= (15x^{0.8} - x) + (80y^{0.6} - 3y) \end{aligned}$$

Note that the production functions of the two paper types aren't really linked. It's as if one firm is doing all the A4, and a different firm is doing all the A3. So to maximize $\Pi(x, y)$, we can just find the maximum value of Π_4 and the maximum value of Π_3 separately.

- (b) Note that $x_4, x_3, x_2 \geq 0$ as we cannot produce negative amount of papers. (Maybe that would mean turning papers into trees?) Note also:

$$\Pi_4(0) = 0 \quad \lim_{x \rightarrow \infty} \Pi_4(x) = -\infty$$

$$\Pi_3(0) = 0 \quad \lim_{y \rightarrow \infty} \Pi_3(y) = -\infty$$

Now let's consider critical points of each function.

$$\frac{d\Pi_4}{dx} = 15(0.8)x^{-0.2} - 1 = 12x^{-0.2} - 1 = 0 \implies x = 12^5$$

$$\Pi_4(12^5) = 15(12^5)^{4/5} - 12^5 = 15(12^4) - 12^5 = 3 \cdot 12^4$$

$$\frac{d\Pi_3}{dy} = 80(0.6)y^{-0.4} - 3 = 48y^{-0.4} - 3 = 0 \implies y = 2^{10}$$

$$\Pi_3(2^{10}) = 80(2^{10})^{6/10} - 3 \cdot 2^{10} = 5 \cdot 2^{10} - 3 \cdot 2^{10} = 2^{11}$$

(Also $x = 0$ and $y = 0$ are critical points, since the derivatives are undefined there, but we've already considered them when we thought about endpoints.)

Since $\Pi_4(12^5) > \Pi_4(0)$ and $\Pi_3(2^{10}) > \Pi_3(0)$, we see our maximum will occur when $x = 12^5$ and $y = 2^{10}$. Then the number of reams produced will be:

$$\begin{aligned} f(12^5) &= \frac{5}{2} (12^5)^{4/5} = 51840 \\ g(2^{10}) &= 10 (2^{10})^{6/10} = 640 \end{aligned}$$

- (c) As we saw before, the two reams are optimized separately. So the optimal production of A3 isn't affected by how much A4 is produced. That is, the branch should stick with $y = 1,024$ leading to 640 reams of A3.

S-19:

- (a) To find Ayan's profit equation, which we denote by Π_A , we just plug in the information we are given in the general profit equation (revenue minus cost).

$$\begin{aligned} \Pi_A(q_A) &= \underbrace{q_A [121 - 2(q_A + q_P)]}_{\text{revenue}} - \underbrace{q_A(1)}_{\text{cost}} \\ &= 121q_A - 2q_A^2 - 2q_Aq_P - q_A \\ &= -2q_A^2 + 120q_A - 2q_Aq_P \end{aligned}$$

This is a parabola pointing down, so its maximum will be at its only critical point.

$$\begin{aligned} \frac{d\Pi_A}{dq_A} &= -4q_A + 120 - 2q_P = 0 \\ 4q_A &= 120 - 2q_P \\ q_1 &= 30 - \frac{1}{2}q_P \end{aligned}$$

So Ayan would maximize their profit by selling $30 - \frac{1}{2}q_P$ servings of lemonade.

- (b) This is very similar to the last part. We find Pipe's profit function.

$$\begin{aligned} \Pi_P(q_P) &= q_P [121 - 2(q_A + q_P)] - q_P(1) \\ &= 121q_P - 2q_P^2 - 2q_Pq_A - q_P \\ &= -2q_P^2 + 120q_P - 2q_Pq_A \end{aligned}$$

Note that this is Π_A if we switch the places of q_A and q_P . So Pipe would maximize their profit by selling $30 - \frac{1}{2}q_A$ pitchers of lemonade.

- (c) Ayan's and Pipe's cost and price for every pitcher of lemonade produced are the same. Their businesses are identical. So we predict that they will sell the same amount of lemonade to maximize their respective profits.

- (d) To find how much each seller will sell when they are working separately, find out which values of q_A and q_P end up with both individual profit functions being maximized. Therefore we solve the system of equations we get from (a) and (b).

$$\begin{aligned} & \begin{cases} q_A &= 30 - \frac{1}{2}q_P \\ q_P &= 30 - \frac{1}{2}q_A \end{cases} \\ \implies q_P &= 30 - \frac{1}{2} \underbrace{\left(30 - \frac{1}{2}q_P\right)}_{q_A} = 15 + \frac{1}{4}q_P \\ \implies q_P &= 20 \\ \implies q_A &= 30 - \frac{1}{2} \underbrace{(20)}_{q_P} = 20 \end{aligned}$$

So, as predicted, both sellers sell the same number of pitchers.

- (e) We need to plug in $q_P = q_A = 20$ in Π_A and Π_P :

$$\Pi_A(20)|_{q_P=20} = -2(20)^2 + 120(20) - 2(20)(20) = 800$$

And similarly, $\Pi_P(20)|_{q_A=20} = 800$. So, they would each make 800 dollars in profit.

- (f) The joint profit function is $\Pi(q_A, q_P) = \Pi_A(q_A) + \Pi_P(q_P)$. Note that here, Ayan and Pipe are helping each other to make the most profit, instead of competing. Using the same intuition as before, we can conclude that $q_A = q_P$ in this case too. (So they share the workload fairly!)

So to make things easier let us assume $q_A = q_P$ and denote this quantity by q . Then $\Pi_A(q) = \Pi_P(q) = -4q^2 + 120q$. This means

$$\begin{aligned} \Pi_{\text{joint}}(q) &= \Pi_A(q) + \Pi_P(q) = 2\Pi_A(q) \\ &= 2(-4q^2 + 120q) \\ &= -8q^2 + 240q \end{aligned}$$

This is a parabola pointing down, so its global min is at its sole critical point, $q = 15$.

So $q = q_A = q_P = 15$ maximizes the joint profit. Let us compute the corresponding joint profit

$$\Pi_{\text{joint}}(15) = -8(15)^2 + 240(15) = 1,800$$

So their optimal joint profit will be 1,800 dollars. But, they need to share this profit among the two of them. So if they collaborate, they will each earn 900 dollars. This is more than their individual optimal profit in the scenario where they are competing found in part (e) (we found this to be \$800). So it is better for them to collaborate!

- (g) When the two sellers collaborate, they sell fewer lemonades (30 pitchers total instead of 40 total) and the lemonade costs more (\$60 instead of \$40). So it's better for consumers when the sellers compete.

S-1: (a) $f(x,y) = x^2 + y^2$ is the square of the distance from the point (x,y) to the origin. There are points on the curve $xy = 1$ that have either x or y arbitrarily large and so whose distance from the origin is arbitrarily large. So f has no maximum on the curve.

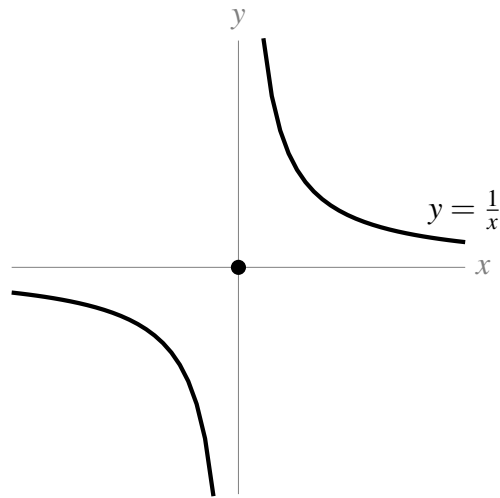

On the other hand f will have a minimum, achieved at the points of $xy = 1$ that are closest to the origin.

(b) On the curve $xy = 1$ we have $y = \frac{1}{x}$ and hence $f = x^2 + \frac{1}{x^2}$. As

$$\frac{d}{dx} \left(x^2 + \frac{1}{x^2} \right) = 2x - \frac{2}{x^3} = \frac{2}{x^3} (x^4 - 1)$$

and as no point of the curve has $x = 0$, the minimum is achieved when $x = \pm 1$. So the minima are at $\pm(1, 1)$, where f takes the value 2.

Remark: this is less a question specifically about Lagrange multipliers and more a question about the existence of extrema on unbounded curves, as in section 16.3.3 in the text.

S-2: The easiest (cheapest?) way out is to think of a function $z = k(x)$ with local but not absolute extrema, then consider the constraint $y = 0$. This puts our function in the xz -plane, effectively making it look just like the function of one-variable $y = f(x)$.

For example, we can set $f(x,y) = x^3 - x$, with constraint function $g(x,y) = y = 0$.

Using techniques from last semester, the function $z = x^3 - x$ has local max at $x = -\frac{1}{\sqrt{3}}$ and local min at $x = \frac{1}{\sqrt{3}}$; but it has no absolute extrema because $\lim_{x \rightarrow \infty} (x^3 - x) = \infty$ and $\lim_{x \rightarrow -\infty} (x^3 - x) = -\infty$.

Similarly, $f(x,y)$ has a local constrained max resp. min at $\left(-\frac{1}{\sqrt{3}}, 0\right)$ resp. $\left(\frac{1}{\sqrt{3}}, 0\right)$; but has no absolute extrema.

S-3: There are none.

For any integer n , $\sin\left(\frac{\pi}{2} + 2\pi n\right) = 1$. So, $f\left(\frac{\pi}{2} + 2\pi n, \frac{\pi}{2} + 2\pi n\right) = \frac{\pi}{2} + 2\pi n$. This satisfies the constraint $x = y$ and, since n can be arbitrarily large or small, has no absolute maximum or minimum.

Alternately, if we set $x = y$, then $f(x, y) = f(x, x) = x \sin x$. This is easy enough to sketch, and then it is easy enough to see that there are no absolute extrema.

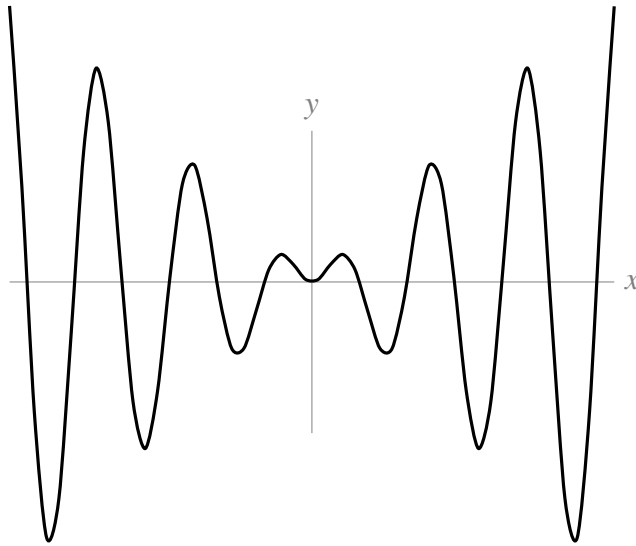

S-4: So we are to minimize $f(x, y) = x^2 + y^2$ subject to the constraint $g(x, y) = x^2 y - 1 = 0$.

The constraint is not a closed curve, so we need to be a little more careful than average. We can interpret our objective function as the distance from the origin squared. So we're trying to find the point on the curve $y = \frac{1}{x^2}$ that is closest to the origin. The distance from points on that curve to the origin can be arbitrarily large, so the system has no absolute maximum. It does have an absolute minimum, which will also be a local minimum, so it will be a solution to the system of Lagrange equations.

According to the method of Lagrange multipliers, we need to find all solutions to

$$f_x = \lambda g_x \qquad 2x = \lambda(2xy) \qquad \text{(E1)}$$

$$f_y = \lambda g_y \qquad 2y = \lambda x^2 \qquad \text{(E2)}$$

$$g(x, y) = 0 \qquad x^2 y = 1 \qquad \text{(E3)}$$

- If $g_x \neq 0$ and $g_y \neq 0$, then $\lambda = \frac{2x}{2xy} = \frac{1}{y}$ by (E1) and $\lambda = \frac{2y}{x^2}$ by (E2).

$$\frac{1}{y} = \frac{2y}{x^2}$$

$$x^2 = 2y^2$$

$$x = \pm\sqrt{2}y$$

Using (E3):

$$1 = x^2 y = (\pm\sqrt{2}y)^2 y$$

$$= 2y^3$$

$$y = \frac{1}{\sqrt[3]{2}}$$

$$x = \pm\sqrt{2} \cdot \frac{1}{\sqrt[3]{2}} = \pm 2^{\frac{1}{2} - \frac{1}{3}} = \pm 2^{\frac{1}{6}}$$

This gives us two solutions: $(\pm 2^{1/6}, 2^{-1/3})$.

- If $g_x = 0$, then $0 = 2xy$. By (E1), $x = 0$; then by (E2), $y = 0$. Then (E3) fails, so there are no solutions of this type.
- If $g_y = 0$, then $0 = x^2$, so $0 = x$. By (E2), $y = 0$. Then (E3) fails, so there are no solutions of this type.

So the two points to check are $(2^{1/6}, 2^{-1/3})$ and $(-2^{1/6}, 2^{-1/3})$. For both of these critical points,

$$x^2 + y^2 = 2^{1/3} + 2^{-2/3} = 2^{1/3} + \frac{1}{2}2^{1/3} = \frac{3}{2}\sqrt[3]{2} = \frac{3}{\sqrt[3]{4}}$$

S-5: For this problem the objective function is $f(x,y) = xy$ and the constraint function is $g(x,y) = x^2 + 2y^2 - 1$. To apply the method of Lagrange multipliers we start by computing the first order derivatives of these functions.

$$f_x = y \quad f_y = x \quad g_x = 2x \quad g_y = 4y$$

So, according to the method of Lagrange multipliers, we need to find all solutions to

$$y = \lambda(2x) \tag{E1}$$

$$x = \lambda(4y) \tag{E2}$$

$$x^2 + 2y^2 - 1 = 0 \tag{E3}$$

- If $g_x \neq 0$ and $g_y \neq 0$, then $\lambda = \frac{y}{2x}$ (E1) and $\lambda = \frac{x}{4y}$.

$$\frac{y}{2x} = \frac{x}{4y}$$

$$2y^2 = x^2$$

From (E3):

$$2y^2 + 2y^2 - 1 = 0$$

$$4y^2 = 1$$

$$y = \pm \frac{1}{2}$$

$$x = \pm \sqrt{2}y = \pm \frac{1}{\sqrt{2}}$$

So four solutions to the system are $(\pm \frac{1}{\sqrt{2}}, \pm \frac{1}{2})$.

- If $g_x = 0$ then $x = 0$; by (E1), $y = 0$; then (E3) fails.
- If $g_y = 0$ then $y = 0$; by (E2), $x = 0$; then (E3) fails.

The method of Lagrange multipliers, Theorem 16.3.3 in the text, gives that the only possible locations of the maximum and minimum of the function f are $(\pm \frac{1}{\sqrt{2}}, \pm \frac{1}{2})$.

point	$(\frac{1}{\sqrt{2}}, \frac{1}{2})$	$(-\frac{1}{\sqrt{2}}, \frac{1}{2})$	$(\frac{1}{\sqrt{2}}, -\frac{1}{2})$	$(-\frac{1}{\sqrt{2}}, -\frac{1}{2})$
$f(x,y)$	$\frac{1}{2\sqrt{2}}$	$-\frac{1}{2\sqrt{2}}$	$-\frac{1}{2\sqrt{2}}$	$\frac{1}{2\sqrt{2}}$
	max	min	min	max

So the maximum and minimum values of f are $\frac{1}{2\sqrt{2}}$ and $-\frac{1}{2\sqrt{2}}$, respectively.

S-6: This is a constrained optimization problem with the objective function being $f(x,y) = x^2 + y^2$ and the constraint function being $g(x,y) = x^4 + y^4 - 1$. By Theorem 16.3.3 in the text, any minimum or maximum (x,y) must obey the Lagrange multiplier equations

$$f_x = g_x \qquad 2x = 4\lambda x^3 \qquad (E1)$$

$$f_y = g_y \qquad 2y = 4\lambda y^3 \qquad (E2)$$

$$g(x,y) = 1 \qquad x^4 + y^4 = 1 \qquad (E3)$$

- If $g_x \neq 0$ and $g_y \neq 0$, then $\lambda = \frac{2x}{4x^3} = \frac{1}{2x^2}$ (E2) and $\lambda = \frac{2y}{4y^3} = \frac{1}{2y^2}$ (E2). So $x^2 = \frac{1}{2\lambda} = y^2$. Then (E3) reduces to

$$2x^4 = 1$$

so that $x^2 = y^2 = \frac{1}{\sqrt{2}}$ and $x = \pm 2^{-1/4}$, $y = \pm 2^{-1/4}$. At all four of these points, we have $f = \sqrt{2}$.

- If $g_x = 0$, then $x = 0$. (E1) holds for any λ , so by choosing λ correctly we can make (E2) hold as well. (E3) reduces to $y^4 = 1$ or $y = \pm 1$. At both $(0, \pm 1)$ we have $f(0, \pm 1) = 1$.
- If $g_y = 0$, then $y = 0$. (E2) holds for any λ , so by choosing λ correctly (E1) holds as well. (E3) reduces to $x^4 = 1$ or $x = \pm 1$. At both $(\pm 1, 0)$ we have $f(\pm 1, 0) = 1$.

So the minimum value of f on $x^4 + y^4 = 1$ is 1 and the maximum value of f on $x^4 + y^4 = 1$ is $\sqrt{2}$.

S-7:

$$f_x = \lambda g_x \qquad 4x^3 = \lambda \cdot 2x \qquad (E1)$$

$$f_y = \lambda g_y \qquad 4y^3 + 4y^5 = \lambda \cdot 2y \qquad (E2)$$

$$g(x,y) = 1 \qquad x^2 + y^2 = 1 \qquad (E3)$$

- If $g_x \neq 0$ and $g_y \neq 0$, then $\lambda = \frac{4x^3}{2x} = 2x^2$ (E1) and $\lambda = \frac{4y^3 + 4y^5}{2y} = (2y^2 + 2y^4)$ (E2). So, $x^2 = \frac{\lambda}{2} = y^2 + y^4$. From (E3):

$$(y^2 + y^4) + y^2 = 1$$

$$y^4 + 2y^2 - 1 = 0$$

$$y^2 = \frac{-2 \pm \sqrt{4 - 4(-1)}}{2}$$

$$= -1 \pm \sqrt{2}$$

$$y^2 = \sqrt{2} - 1$$

In this case, $x^2 = 1 - y^2 = 2 - \sqrt{2}$. So, we should check $(\pm\sqrt{2 - \sqrt{2}}, \pm\sqrt{\sqrt{2} - 1})$.

- If $g_x = 0$, then $x=0$. Then (E1) is true for any λ , which means we can make (E2) be true by choosing λ accordingly. By (E3), $x = 0 \implies y = \pm 1$, so we should check $(0, \pm 1)$
- If $g_y = 0$, then $y = 0$. Then (E2) is true for any λ , which means we can make (E1) be true by choosing λ accordingly. By (E3), $y = 0 \implies x = \pm 1$, so we should check $(\pm 1, 0)$

Comparing:

- $f(0, \pm 1) = 0 + 1 + \frac{2}{3} = \frac{5}{3}$
- $f(\pm 1, 0) = 1 + 0 + 0 = 1$
- When $x^2 = 2 - \sqrt{2}$ and $y^2 = \sqrt{2} - 1$, then

$$\begin{aligned} f(x,y) &= (2 - \sqrt{2})^2 + (\sqrt{2} - 1)^2 + \frac{2}{3}(\sqrt{2} - 1)^3 \\ &= \frac{13 - 8\sqrt{2}}{3} \end{aligned}$$

Since $\sqrt{2} > \frac{5}{4}$, we see

$$\frac{13 - 8\sqrt{2}}{3} < \frac{13 - 8(5/4)}{3} = \frac{13 - 10}{3} = 1$$

So, our absolute min over the constraint is $\frac{13-8\sqrt{2}}{3}$, and our absolute max over the constraint is $\frac{5}{3}$.

S-8: (It's possible to solve this without Lagrange, but we were asked to use Lagrange to practice the technique.)

We want to minimize $\sqrt{x^2 + y^2}$, the distance from the origin to a point (x, y) . Note the minimum of that function will occur at the same (x, y) -values as the minimum of its square, $x^2 + y^2$. Since that's easier to minimize, we use it as our objective function: $f(x, y) = x^2 + y^2$.

We only care about coordinates that are actually on the parabola, so our constraint function is $g(x, y) = y + x^2 = \frac{3}{2}$.

Our constraint function is not a closed curve. We can keep travelling along the parabola to end up arbitrarily far from the origin. So there's no global maximum distance, but there is a global minimum distance. The global minimum will also be a local minimum, so it will be a solution to the Lagrange equations.

$$f_x = \lambda g_x \qquad 2x = \lambda 2x \qquad \text{(E1)}$$

$$f_y = \lambda g_y \qquad 2y = \lambda \qquad \text{(E2)}$$

$$g(x, y) = \frac{3}{2} \qquad y + x^2 = \frac{3}{2} \qquad \text{(E3)}$$

- If $g_x \neq 0$ and $g_y \neq 0$, then $\lambda = 1$ from (E1) and $\lambda = 2y$ from (E2), so $1 = 2y$, i.e. $y = \frac{1}{2}$. From (E3), then $x = \pm 1$.

- If $g_x = 0$, then $x = 0$, so (E1) is true for any λ . Then we can make (E2) true by choosing the appropriate λ ; from (E3), $y = \frac{3}{2}$. So another point solving the system is $(0, \frac{3}{2})$.
- There are no points corresponding to $g_y = 0$.

$f(0, \frac{3}{2}) = \frac{9}{4}$ and $f(\pm 1, \frac{1}{2}) = \frac{5}{4}$. So, the closest points to the origin on the parabola are the points $(-1, 1/2)$ and $(1, 1/2)$.

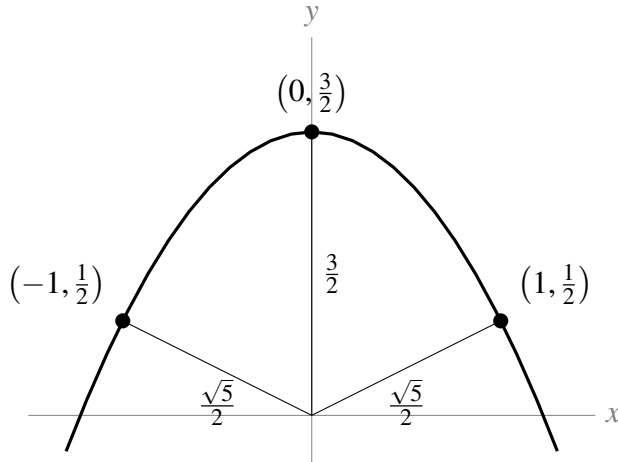

S-9:

To find extrema over a region, we check CPs and the boundary.

$f(x,y) = xy$, so $f_x = y$ and $f_y = x$. Then the only CP is $(0,0)$.

To check the boundary, we need to know the extreme values of $f(x,y) = xy$ over the ellipse $x^2 - 2xy + 5y^2 = 1$. It seems tough to do this with plugging in, so we use Lagrange.

$$\begin{aligned} f_x &= \lambda g_x & y &= \lambda(2x - 2y) & \text{(E1)} \\ f_y &= \lambda g_y & x &= \lambda(-2x + 10y) & \text{(E2)} \\ g(x,y) &= 1 & x^2 - 2xy + 5y^2 &= 1 & \text{(E3)} \end{aligned}$$

- If $g_x \neq 0$ and $g_y \neq 0$, then $\lambda = \frac{y}{2(x-y)}$ and $\lambda = \frac{x}{2(5y-x)}$:

$$\begin{aligned} \frac{y}{2(x-y)} &= \frac{x}{2(5y-x)} \\ 5y^2 - xy &= x^2 - xy \\ x &= \pm\sqrt{5}y \end{aligned}$$

From (E3), if $x = \sqrt{5}y$:

$$\begin{aligned} 1 &= 5y^2 - 2(\sqrt{5}y)y + 5y^2 \\ &= (10 - 2\sqrt{5})y^2 \\ \frac{1}{10 - 2\sqrt{5}} &= y^2 \\ y &= \pm \frac{1}{\sqrt{10 - 2\sqrt{5}}} \end{aligned}$$

From (E3), if $x = -\sqrt{5}y$:

$$1 = (10 + 2\sqrt{5})y^2$$
$$y = \pm \frac{1}{\sqrt{10 + 2\sqrt{5}}}$$

This gives us four points to check: $\left(\sqrt{\frac{5}{10-2\sqrt{5}}}, \pm \frac{1}{\sqrt{10-2\sqrt{5}}}\right)$ and $\left(\sqrt{\frac{5}{10+2\sqrt{5}}}, \pm \frac{1}{\sqrt{10+2\sqrt{5}}}\right)$.

- If $g_x = 0$, then (E1) $y = 0$, so $0 = g_x = 2x - 2y = 2x$, hence $x = 0$. But then (E3) fails.
- If $g_y = 0$, then (E2) $x = 0$, so $0 = g_y = -2x + 10y = 10y$, hence $y = 0$. But then (E3) fails.

All together, we've identified 5 possible locations of extrema.

- $f(0,0) = 0$
- $f\left(\sqrt{\frac{5}{10-2\sqrt{5}}}, \frac{1}{\sqrt{10-2\sqrt{5}}}\right) = \frac{\sqrt{5}}{10-2\sqrt{5}}$
- $f\left(\sqrt{\frac{5}{10-2\sqrt{5}}}, -\frac{1}{\sqrt{10-2\sqrt{5}}}\right) = -\frac{\sqrt{5}}{10-2\sqrt{5}}$
- $f\left(\sqrt{\frac{5}{10+2\sqrt{5}}}, \frac{1}{\sqrt{10+2\sqrt{5}}}\right) = \frac{\sqrt{5}}{10+2\sqrt{5}}$
- $f\left(\sqrt{\frac{5}{10+2\sqrt{5}}}, -\frac{1}{\sqrt{10+2\sqrt{5}}}\right) = -\frac{\sqrt{5}}{10+2\sqrt{5}}$

The largest and smallest of these are $\frac{\sqrt{5}}{10-2\sqrt{5}}$ and $\frac{-\sqrt{5}}{10-2\sqrt{5}}$, respectively.

S-10: By way of preparation, we have

$$\frac{\partial T}{\partial x}(x,y) = 2xe^y \quad \frac{\partial T}{\partial y}(x,y) = e^y(x^2 + y^2 + 2y)$$

(a) (i) For this problem the objective function is $T(x,y) = e^y(x^2 + y^2)$ and the constraint function is $g(x,y) = x^2 + y^2 - 100$. According to the method of Lagrange multipliers, Theorem 16.3.3 in the text, we need to find all solutions to

$$T_x = \lambda g_x \quad 2xe^y = \lambda(2x) \quad (\text{E1})$$

$$T_y = \lambda g_y \quad e^y(x^2 + y^2 + 2y) = \lambda(2y) \quad (\text{E2})$$

$$g(x,y) = 100 \quad x^2 + y^2 = 100 \quad (\text{E3})$$

(a) (ii)

- If $g_x \neq 0$ and $g_y \neq 0$, then (E1) $\lambda = e^y$ and (E2) $\lambda = \frac{e^y(x^2 + y^2 + 2y)}{2y}$.

$$e^y = \frac{e^y(x^2 + y^2 + 2y)}{2y}$$

$$2y = x^2 + y^2 + 2y$$

$$0 = x^2 + y^2$$

but this conflicts with (E3). So $g_x \neq 0$ and $g_y \neq 0$ doesn't lead to any solutions.

- If $g_x = 0$, then $x = 0$ and (E1) is true; then we can choose the appropriate l to make (E2) true. From (E3), $y = \pm 10$. So $(0, \pm 10)$ gives a solution.
- If $g_y = 0$, then $y = 0$. By (E2), $x = 0$, which conflicts with (E3).

So the only possible locations of the maximum and minimum of the function T are $(0, 10)$ and $(0, -10)$. To complete this part of the problem, we only have to compute T at those points.

point	$(0, 10)$	$(0, -10)$
value of T	$100e^{10}$	$100e^{-10}$
	max	min

Hence the maximum value of $T(x, y) = e^y(x^2 + y^2)$ on $x^2 + y^2 = 100$ is $100e^{10}$ at $(0, 10)$ and the minimum value is $100e^{-10}$ at $(0, -10)$.

We remark that, on $x^2 + y^2 = 100$, the objective function $T(x, y) = e^y(x^2 + y^2) = 100e^y$. So of course the maximum value of T is achieved when y is a maximum, i.e. when $y = 10$, and the minimum value of T is achieved when y is a minimum, i.e. when $y = -10$.

(b) (i) By definition, the point (x, y) is a critical point of $T(x, y)$ if and only if the first order partial derivatives at that point are both zero, or at least one does not exist. The first partial derivatives

$$\begin{aligned} T_x &= 2xe^y \\ T_y &= e^y(x^2 + y^2 + 2y) \end{aligned}$$

are well defined everywhere and so the critical points are exactly the point where

$$T_x = 2xe^y = 0 \tag{E1}$$

$$T_y = e^y(x^2 + y^2 + 2y) = 0 \tag{E2}$$

(b) (ii) Equation (E1) forces $x = 0$. When $x = 0$, equation (E2) reduces to

$$e^y(y^2 + 2y) = 0 \iff y(y + 2) = 0 \iff y = 0 \text{ or } y = -2$$

So there are two critical points, namely $(0, 0)$ and $(0, -2)$.

(c) Note that $T(x, y) = e^y(x^2 + y^2) \geq 0$ on all of \mathbb{R}^2 . As $T(x, y) = 0$ only at $(0, 0)$, it is obvious that $(0, 0)$ is the coolest point.

In case you didn't notice that, here is a more conventional solution.

The coolest point on the solid disc $x^2 + y^2 \leq 100$ must either be on the boundary, $x^2 + y^2 = 100$, of the disc or be in the interior, $x^2 + y^2 < 100$, of the disc.

In part (a) (ii) we found that the coolest point on the boundary is $(0, -10)$, where $T = 100e^{-10}$.

If the coolest point is in the interior, it must be a critical point and so must be either $(0, 0)$, where $T = 0$, or $(0, -2)$, where $T = 4e^{-2}$.

So the coolest point is $(0, 0)$.

S-11: Since $x \geq 0$ and $y \geq 0$, our constraint function has endpoints $(x,y) = (0,400)$ and $(x,y) = (25,0)$. Absolute extrema will occur at these endpoints or at points that solve the system of Lagrange equations.

$$f_x = \lambda g_x \qquad 3x^{-\frac{2}{3}}y^{\frac{2}{3}} = 3200\lambda \qquad (E1)$$

$$f_y = \lambda g_y \qquad 6x^{\frac{1}{3}}y^{-\frac{1}{3}} = 200\lambda \qquad (E2)$$

$$g(x,y) = 80,000 \qquad 3200x + 200y = 80,000 \qquad (E3)$$

Since g_x and g_y are always nonzero, we only have one of our usual three cases.

$$\begin{aligned} 3x^{-\frac{2}{3}}y^{\frac{2}{3}} \cdot \frac{1}{3200} &= 6x^{\frac{1}{3}}y^{-\frac{1}{3}} \cdot \frac{1}{200} \\ x^{-\frac{2}{3}}y^{\frac{2}{3}} &= 32x^{\frac{1}{3}}y^{-\frac{1}{3}} \\ y^{\frac{1}{3}}y^{\frac{2}{3}} &= 32x^{\frac{1}{3}}x^{\frac{2}{3}} \\ y &= 32x \\ 3200x + 200(32x) &= 80,000 \\ x &= \frac{25}{3} \\ y &= \frac{25 \cdot 32}{3} = \frac{800}{3} \end{aligned}$$

Now we compare our three points of interest.

point	$(0,400)$	$(25,0)$	$(\frac{25}{3}, \frac{800}{3})$
$f(x,y)$	0	0	$75 \cdot 2^{10/3}$
	min	min	max

S-12: The constraint tells us

$$g(a,b) = a + 2b = 1$$

The triangle formed is a right triangle with area $\frac{1}{2}bh$. Its base and height are the two intercepts of the line. That is, its base is $\frac{1}{a}$, and its height is $\frac{1}{b}$. So, the area (which we want to minimize) is

$$f(x,y) = \frac{1}{2} \cdot \frac{1}{a} \cdot \frac{1}{b}$$

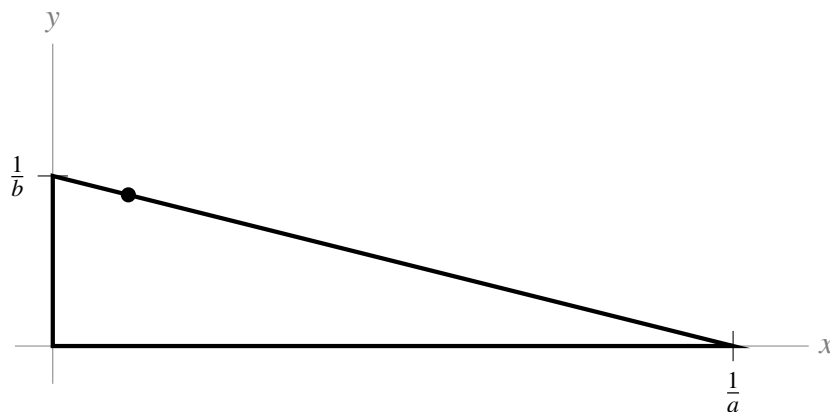

By choosing lines with slopes close to 0, or large negative slopes, we can make triangles with arbitrarily large area. So the absolute minimum will occur somewhere in between at a local minimum value. So we can find the absolute minimum using the method of Lagrange multipliers.

$$f_a = \lambda g_a \qquad -\frac{1}{2a^2b} = \lambda(1) \qquad (E1)$$

$$f_b = \lambda g_b \qquad -\frac{1}{2ab^2} = \lambda(2) \qquad (E1)$$

Since g_a and g_b can't be 0, we have only one of our usual three cases.

$$\begin{aligned} -\frac{1}{2a^2b} &= -\frac{1}{2} \cdot \frac{1}{2ab^2} \\ \frac{1}{a} &= \frac{1}{2b} \\ a &= 2b \end{aligned}$$

Using our constraint,

$$\begin{aligned} 2b + 2b &= 1 \\ b &= \frac{1}{4} \\ a &= \frac{1}{2} \end{aligned}$$

So the minimum area is achieved by the line $\frac{1}{2}x + \frac{1}{4}y = 1$. That area is $\frac{1}{2} \cdot 4 \cdot 2 = 4$.

S-13: The ellipse $\frac{x^2}{a^2} + \frac{y^2}{b^2} = 1$ passes through the point $(1,2)$ if and only if $\frac{1}{a^2} + \frac{4}{b^2} = 1$. We are to minimize

$$f(a,b) = \pi ab$$

subject to the constraint that

$$g(a,b) = \frac{1}{a^2} + \frac{4}{b^2} - 1 = 0.$$

We can imagine ellipses centred at the origin passing through $(1,2)$ of arbitrarily large size.

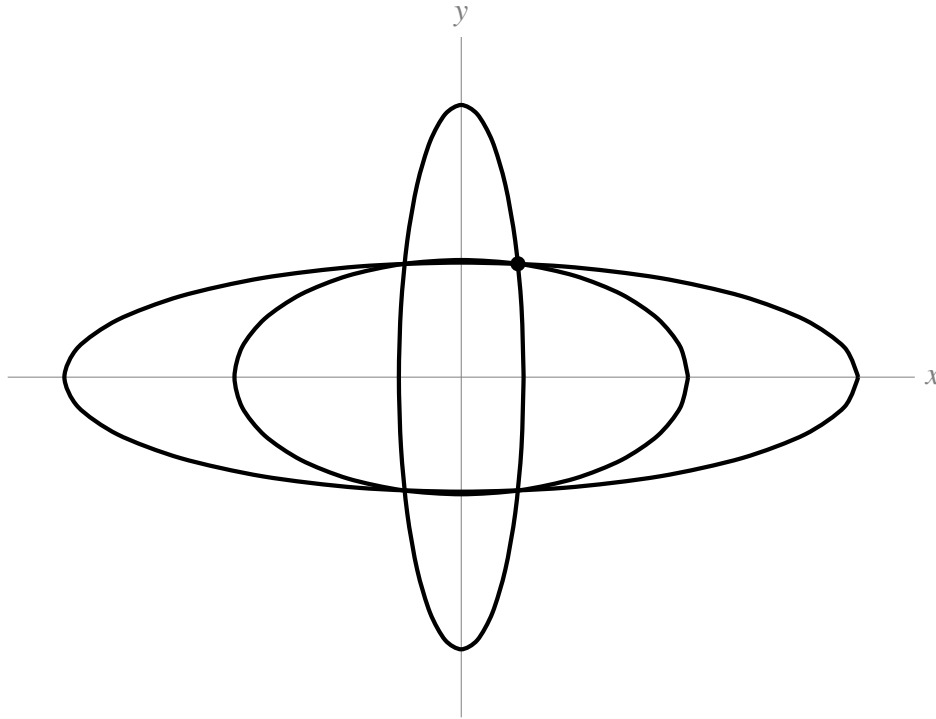

For large values of a (and corresponding values of b approaching 2), we have a large area. Similarly, for large values of b (and corresponding values of a approaching 2), we have a large area. So there's no absolute maximum, but there is a "sweet spot" where a and b are both not too large and we have a global minimum. It will also be a local minimum.

According to the method of Lagrange multipliers, we need to find all solutions to the system:

$$f_a = \lambda g_a \quad \pi b = -\frac{2\lambda}{a^3} \quad (\text{E1})$$

$$f_b = \lambda g_b \quad \pi a = -\frac{8\lambda}{b^3} \quad (\text{E2})$$

$$g(a,b) = 0 \quad \frac{1}{a^2} + \frac{4}{b^2} = 1 \quad (\text{E3})$$

- If $g_a \neq 0$ and $g_b \neq 0$, then (E1) $\lambda = -\frac{\pi a^3 b}{2}$ and (E2) $\lambda = -\frac{\pi a b^3}{8}$.

$$-\frac{\pi a^3 b}{2} = -\frac{\pi a b^3}{8}$$

$$4a^3 b = ab^3$$

$$4a^3 b - ab^3 = 0$$

$$ab(4a^2 - b^2) = 0$$

This last equation has solutions $a = 0$, $b = 0$, and $4a^2 = b^2$. The first two aren't in our model domain, since a and b are positive. In the third case:

$$\begin{aligned} 1 &= \frac{1}{a^2} + \frac{4}{4a^2} \\ &= \frac{1}{a^2} + \frac{1}{a^2} = \frac{2}{a^2} \end{aligned}$$

Remember $a > 0$ and $b > 0$.

$$\begin{aligned} a &= \sqrt{2} \\ b^2 &= 4a^2 = 4 \cdot 2 \\ b &= 2\sqrt{2} \end{aligned}$$

- If $g_a = 0$ or $g_b = 0$, then the constraint fails.

So, the only possible location of a local extremum is $a = \sqrt{2}$, $b = 2\sqrt{2}$. This is the location of our absolute minimum.

S-14: Let r and h denote the radius and height, respectively, of the cylinder. We can always choose our coordinate system so that the axis of the cylinder is parallel to the z -axis.

- If the axis of the cylinder does not lie exactly on the z -axis, we can enlarge the cylinder sideways. (See the figure on the left below. It shows the $y = 0$ cross-section of the cylinder.) So we can assume that the axis of the cylinder lies on the z -axis
- If the top and/or the bottom of the cylinder does not touch the sphere $x^2 + y^2 + z^2 = 1$, we can enlarge the cylinder vertically. (See the central figure below.)
- So we may assume that the cylinder is

$$\{ (x, y, z) \mid x^2 + y^2 \leq r^2, -h/2 \leq z \leq h/2 \}$$

with $r^2 + (h/2)^2 = 1$. See the figure on the right below.

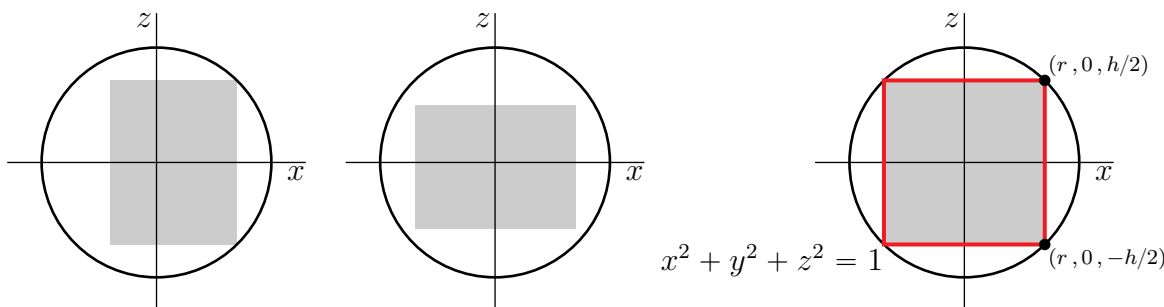

So we are to maximize the volume, $f(r, h) = \pi r^2 h$, of the cylinder subject to the constraint $g(r, h) = r^2 + \frac{h^2}{4} - 1 = 0$. According to the method of Lagrange multipliers, we need to find all solutions to

$$f_r = g_r \qquad 2\pi r h = 2\lambda r \qquad \text{(E1)}$$

$$f_h = g_h \qquad \pi r^2 = \lambda \frac{h}{2} \qquad \text{(E2)}$$

$$g(r, h) = 1 \qquad r^2 + \frac{h^2}{4} = 1 \qquad \text{(E3)}$$

- If $g_r \neq 0$ and $g_h \neq 0$, then (E1) gives us $\lambda = \frac{2\pi r h}{2r} = \pi h$ and (E2) gives us $\lambda = \frac{\pi r^2}{h/2} = \frac{2\pi r^2}{h}$.

$$\begin{aligned} \pi h &= \frac{2\pi r^2}{h} \\ \frac{h^2}{2} &= r^2 \end{aligned}$$

Now from (E3):

$$\begin{aligned}1 &= r^2 + \frac{h^2}{4} = \frac{h^2}{2} + \frac{h^2}{4} \\ &= \frac{3}{4}h^2 \\ h^2 &= \frac{4}{3}\end{aligned}$$

Since h and r are nonnegative,

$$\begin{aligned}h &= \frac{2}{\sqrt{3}} \\ r &= \sqrt{\frac{h^2}{2}} = \frac{h}{\sqrt{2}} = \sqrt{\frac{2}{3}}\end{aligned}$$

So one point to check is $r = \sqrt{\frac{2}{3}}$, $h = \frac{2}{\sqrt{3}}$.

- If $g_r = 0$, then $r = 0$. Then (E1) is true for any λ and any r . From (E2), $h = 0$. But then (E3) fails.
- If $g_h = 0$, then $h = 0$. From (E2), $r = 0$. But then (E3) fails.

So the only solution to all three equations with $r > 0$ and $h > 0$ is $r = \sqrt{\frac{2}{3}}$, $h = \frac{2}{\sqrt{3}}$. Since we restricted our domain to non-negative values of r and h , the points with $r = 0$ or with $h = 0$ are “endpoints” of the region we’re considering. At these points, our volume is 0, so they give us the global minimum value over our model domain.

So, $r = \sqrt{\frac{2}{3}}$, $h = \frac{2}{\sqrt{3}}$ give the cylinder with maximum volume.

S-15:

The function we want to minimize is surface area, so this is our objective function:

$$f(x,y) = 2(2x \cdot x) + 2(2x \cdot y) + 2(x \cdot y) = 4x^2 + 6xy$$

Our constraint is that the volume must be 72 cubic centimetres.

$$g(x,y) = x \cdot 2x \cdot y = 2x^2y = 72$$

This is not a closed curve. If we think of y as a function of x , then our constraint gives us $y = \frac{36}{x^2}$, $x > 0$, $y > 0$. So this curve has domain $0 < x$. Note that as x approaches 0, then y approaches infinity, and vice-versa. (That is: to have a very very short box with fixed volume, the box must be very wide.) Then our objective function goes to infinity as well. So this system *has no global maximum*, but it does have a global minimum. That global minimum will also be a local minimum, so it will be a solution to the system of Lagrange equations.

$$f_x = \lambda g_x \qquad 8x + 6y = \lambda(4xy) \qquad \text{(E1)}$$

$$f_y = \lambda g_y \qquad 6x = \lambda(2x^2) \qquad \text{(E2)}$$

$$g(x,y) = 72 \qquad 2x^2y = 72 \qquad \text{(E3)}$$

-
- If $g_x \neq 0$ and $g_y \neq 0$, then (E1) $\lambda = \frac{8x+6y}{4xy} = \frac{4x+3y}{2xy}$ and (E2) $\lambda = \frac{6x}{2x^2} = \frac{3}{x}$:

$$\begin{aligned}\frac{4x+3y}{2xy} &= \frac{3}{x} \\ \implies 4x^2 + 3xy &= 6xy \\ \implies 4x^2 - 3xy &= 0 \\ \implies x(4x - 3y) &= 0 \\ \implies x = 0 \text{ or } (4x - 3y) &= 0\end{aligned}$$

From (E3), we see $x \neq 0$, so the only point to consider is when $4x = 3y$. Plugging this into our constraint function,

$$\begin{aligned}72 &= 2x^2y = 2x^2\left(\frac{4}{3}x\right) = 3x^3 \\ \implies 27 &= x^3 \\ \implies 3 &= x \\ \implies y &= \frac{4}{3} \cdot 3 = 4\end{aligned}$$

So the point to consider is $(3, 4)$.

- If $g_x = 0$, then $x = 0$ or $y = 0$, both of which make (E3) false.
- If $g_y = 0$, then $x = 0$, which makes (E3) false.

So the only point to consider is $(3, 4)$.

We aren't considering a region with a closed curve bounding it, so we'll need some thought to decide whether this is, in fact, a minimum. Note that our model domain is that x and y must both be positive numbers. We see that as x or y goes to 0, while the other one stays constant, our surface area function goes to infinity. Similarly as x or y goes to infinity, while the other one stays constant, our surface area function goes to infinity. So the function must have a minimum somewhere well away from its "boundaries" near and far from the x and y axes.

So, the dimensions of the box with smallest surface area are:

$$x = 3, \quad 2x = 6, \quad y = 4$$

S-16: Note that if (x, y) obeys $g(x, y) = xy - 1 = 0$, then x is necessarily nonzero. So we may

assume that $x \neq 0$. Then

There is a λ such that (x, y, λ) obeys (E1)

$$\iff \text{there is a } \lambda \text{ such that } f_x(x, y) = \lambda g_x(x, y), \quad f_y(x, y) = \lambda g_y(x, y), \quad g(x, y) = 0$$

$$\iff \text{there is a } \lambda \text{ such that } f_x(x, y) = \lambda y, \quad f_y(x, y) = \lambda x, \quad xy = 1$$

$$\iff \text{there is a } \lambda \text{ such that } \frac{1}{y}f_x(x, y) = \frac{1}{x}f_y(x, y) = \lambda, \quad xy = 1$$

$$\iff \frac{1}{y}f_x(x, y) = \frac{1}{x}f_y(x, y), \quad xy = 1$$

$$\iff xf_x\left(x, \frac{1}{x}\right) = \frac{1}{x}f_y\left(x, \frac{1}{x}\right), \quad y = \frac{1}{x}$$

$$\iff F'(x) = \frac{d}{dx}f\left(x, \frac{1}{x}\right) = f_x\left(x, \frac{1}{x}\right) - \frac{1}{x^2}f_y\left(x, \frac{1}{x}\right) = 0, \quad y = \frac{1}{x}$$

S-17: Solution 1

Since $f(x, y)$ is the square root of something, its unconstrained absolute minimum is 0, achieved whenever $4x^4 + y^4 = 1$. By choosing x and/or y to be large, we see $f(x, y)$ will be large as well. That is, $f(x, y)$ has no unconstrained maximum.

By inspection (“staring at it”), we note the point $(0, 1)$ satisfies both our constraint and $4x^4 + y^4 = 1$. So the constrained absolute minimum is 0, and this is achieved at $(0, 1)$. Since x and y can have arbitrarily large absolute values and still satisfy $x^3 + y^3 = 1$, we see that $f(x, y)$ has no constrained minimum.

Solution 2

First, let’s consider temporarily replacing $f(x, y)$ with

$$h(x, y) = 4x^4 + y^4 - 1$$

When $h(x, y)$ is large, then $f(x, y)$ is large; when $h(x, y)$ is small and positive, then $f(x, y)$ is small. So the extrema of $f(x, y)$ should occur at extrema of $h(x, y)$ or at points where $h(x, y) = 0$.

The benefit of this replacement is that h is much easier to differentiate. Let’s use the method of Lagrange multipliers. First, we differentiate.

$$\begin{array}{ll} h_x = 16x^3 & g_x = 3x^2 \\ h_y = 4x^3 & g_y = 3y^2 \end{array}$$

So, we solve

$$\begin{array}{lll} 16x^3 = \lambda \cdot 3x^2 & \implies x = 0 & \text{or } \lambda = \frac{16}{3}x \\ 4y^3 = \lambda \cdot 3y^2 & \implies y = 0 & \text{or } \lambda = \frac{4}{3}y \end{array}$$

1. If $x = 0$, then from $x^3 + y^3 = 1$, we require $y = 1$. So the point $(0, 1)$ is a point to check.

$$h(0, 1) = 0$$

2. If $y = 0$, then from $x^3 + y^3 = 1$, we require $x = 1$. So the point $(1, 0)$ is a point to check.

$$h(1, 0) = 3$$

3. If neither $x = 0$ nor $y = 0$, then $\lambda = \frac{16}{3}x = \frac{4}{3}y$, so $y = 4x$. Then from our constraint,

$$\begin{aligned}x^3 + y^3 &= 1 \\x^3 + (4x)^3 &= 1 \\65x^3 &= 1 \\x &= \frac{1}{\sqrt[3]{65}} \\y = 4x &= \frac{4}{\sqrt[3]{65}}\end{aligned}$$

So, $\left(\frac{1}{\sqrt[3]{65}}, \frac{4}{\sqrt[3]{65}}\right)$ is a point to check.

$$\begin{aligned}h\left(\frac{1}{\sqrt[3]{65}}, \frac{4}{\sqrt[3]{65}}\right) &= 4\left(\frac{1}{\sqrt[3]{65}}\right)^4 + \left(\frac{4}{\sqrt[3]{65}}\right)^4 - 1 \\&= \frac{4 + 4^4}{65^{4/3}} - 1 \\&= \frac{4(1 + 4^3)}{(1 + 4^3)^{4/3}} - 1 \\&= \frac{4}{(1 + 4^3)^{1/3}} - 1 \\&< \frac{4}{(4^3)^{1/3}} - 1 = 0\end{aligned}$$

So the point $\left(\frac{1}{\sqrt[3]{65}}, \frac{4}{\sqrt[3]{65}}\right)$ is not in the domain of $f(x, y)$.

Since $f(x, y)$ can never be less than 0, and $f(0, 1) = 0$, we see that this is the absolute minimum subject to the constraint.

If $g(x, y) = 1$ were a *closed curve*, such as an ellipse, then we would be guaranteed that a constrained absolute maximum existed, and then that constrained absolute maximum would occur at a point identified above: by process of elimination, $(1, 0)$. However, $g(x, y) = 1$ is *not* a closed curve. For any value of x , $g(x, y) = 1$ has a solution. That means our constraint contains arbitrarily large values of x . Huge values of x will lead to huge values of $f(x, y)$, so there is *no* constrained absolute maximum.

S-18: Both the objective and constraint functions are fairly straightforward to understand.

- If x and y are both large and positive, then $f(x, y)$ is large and positive; if x and y are both large and negative, then $f(x, y)$ is large and negative.
- If $|y|$ is large, then $|x| = \sqrt{1 + y^2}$ is large as well.

So if we take y to be arbitrarily large and positive, and x to be (positive) $\sqrt{1+y^2}$, then $f(x,y) = x+y > y$ is arbitrarily large.

Similarly, if we take y to be arbitrarily large and negative, and x to be $-\sqrt{1+y^2}$, then $f(x,y) = x+y < y$ is arbitrarily large and negative.

So, there are no absolute extrema of $f(x,y)$ subject to the constraint $x^2 = 1+y^2$.

S-19:

- (a) Note $f(x,0) = x$, which has no absolute extrema. So $f(x,y)$ has no absolute extrema, either.
- (b) The line $y = x$ does not describe a closed curve: it's a line that continues on forever without "looping back" on itself.
- (c) The plugging-in method of earlier times fits our functions well, so we won't bother with Lagrange. If $x = y$, then:

$$f(x,x) = \frac{x}{1+x^4}$$

So, let's consider a function of one variable, call it k .

$$k(x) = \frac{x}{1+x^4}$$

To get a feel for $k(x)$, first note its horizontal asymptotes:

$$\lim_{k \rightarrow \infty} k(x) = \lim_{k \rightarrow -\infty} k(x) = 0$$

(since k is rational and the degree of its numerator is smaller than the degree of its denominator). So, far away from the origin, $k(x) \approx 0$. Also, we note that $k(x)$ is defined for all real numbers.

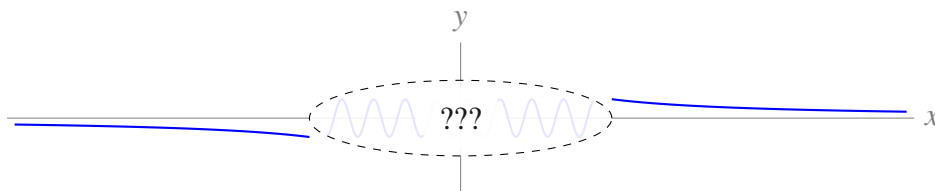

Since $k(x)$ is continuous, even without sketching the rest of its graph, we can already see $k(x)$ has absolute extrema. These will occur at critical points. So, we differentiate. Using the

quotient rule:

$$\begin{aligned}k'(x) &= \frac{(1+x^4)(1) - x(4x^3)}{(1+x^4)^2} = \frac{1-3x^4}{(1+x^4)^2} \\0 &= \frac{1-3x^4}{(1+x^4)^2} \\0 &= 1-3x^4 \\x &= \pm \frac{1}{\sqrt[4]{3}} \\k\left(\frac{1}{\sqrt[4]{3}}\right) &= \frac{\frac{1}{\sqrt[4]{3}}}{1+\frac{1}{3}} = \frac{3}{4} \cdot \frac{1}{\sqrt[4]{3}} = \frac{3^{3/4}}{4} \\k\left(-\frac{1}{\sqrt[4]{3}}\right) &= -\frac{3^{3/4}}{4}\end{aligned}$$

The absolute maximum of $k(x)$ is $\frac{3^{3/4}}{4}$ and the absolute minimum of $k(x)$ is $-\frac{3^{3/4}}{4}$. That is:

The absolute maximum of $f(x,y)$ constrained to $x=y$ is $\frac{3^{3/4}}{4}$ and the absolute minimum of $f(x,y)$ constrained to $x=y$ is $-\frac{3^{3/4}}{4}$.

Remark: the purpose of this exercise is to point out that, even when a constraint is not a closed curve, it is still possible for a constrained function to have both an absolute max and an absolute min.

INCLUDED CONTENT

Keshet Ch 11, 103
Keshet Ch 12, 109
Keshet Ch 13, 117
Keshet Ch 5, 101
Keshet Ch 7, 84

Keshet Ch1, 19
Keshet Ch12, 112

New content, 101
new content, 113